

## Part Number: IE-5WW-C-1F

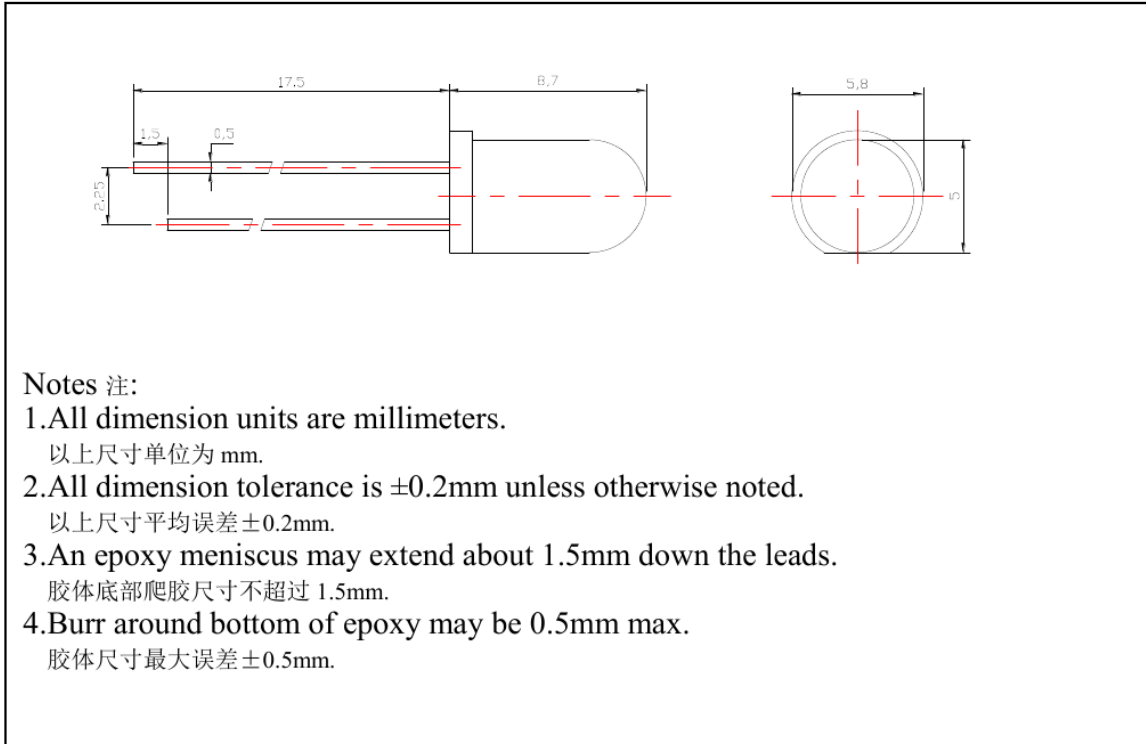

### ■ Features 特征:

- The service life is long 使用寿命长
- The credibility is strong 可靠性强

● Environmental protection, economy

energy 环保、节能

### ■ Descriptions 产品描述:

- The series is specially designed for application requiring higher brightness.  
此系列专用于高亮需求领域

### ■ Applications 适用范围:

- Illuminate 照明
- Monitor 监视器
- Backlight 背光

## Part Number: IE-5WW-C-1F

Chip		Lens Color 胶体颜色
Material 材质	Emitting Color 发光颜色	
InGaN	White	Water clear

### ■ Absolute Maximum Ratings at Ta=25 °C 极限参数（环境温度 Ta=25 °C）

Parameter 参数	Symbol 符号	Rating 范围	Unit 单位
Forward Current 正向工作电流	IF	20	mA
Operating Temperature 正常使用温度	Topr	-25 to +80	°C
Storage Temperature 贮藏温度	Tstg	-25 to +80	°C
Soldering Temperature 可焊接温度	Tsol	260	°C
Power Dissipation 极限功耗	Pd	50	mW
Peak Forward Current (Duty1/10@1kHz) 脉冲驱动时极 限正向电流 1 msec 脉冲	IF(Peak)	100	mA
Reverse Voltage 反向冲击电压	VR	5	V

### ■ Electronic Optical Characteristics 光电特性

Parameter 参数	Symbol 符号	Min. 最小值	Typ. 中间值	Max. 最大值	Unit 单位	Condition 测试条件值
Luminous Intensity 发光亮度	IV	90000	10000	12000	mcd	IF=20mA
Viewing Angle 发光角度	2θ½	/	15	/	deg	IF=20mA
Peak Wavelength 峰值波长	X	/		/	/	IF=20mA
	Y		4000		/K	
Forward Voltage 正向电压降	Vf	3.2		3.4	V	IF=20mA
Reverse Current 反向电流	IR	/	/	5	μA	VR=5V

## Part Number: IE-5WW-C-1F

---

Suggestions to customers 使用注意事项:

- 1、 Soldering Bath at  $260^{\circ}\text{C} \pm 5^{\circ}\text{C}$  with in 3 seconds.(Dip depth should under 6mm below seating plane.) 焊接温度要求在  $260^{\circ}\text{C} \pm 5^{\circ}\text{C}$  范围内不超过 5 秒 (焊点位置应至少低于底座的 4mm)
- 2、 The neutrality flux must be used before soldering.焊接时要求用中性助焊剂

CLEANING 清洁:

Do not use unspecified chemical liquid to clean LED.They could harm it IF cleaning is necessary, wipe the pin out with alcohol、Freon TE or Chlorosen at normal temperature for less than 1 minute or wipe the surface with alcohol.禁止使用不明化学液体擦拭发光管器件, 以免导致伤害材料。如果一定要擦拭材料, 建议使用酒精、VREONTE 或 CHLOROSEN 在常温下擦拭不超过 1 分钟。

METHODS AGAINST STATIC ELECTRICITY 防静电工艺:

Static electricity is the enemy of lamps emitting blue and green. Workers must put on working rings、gloves clothes that protect static electricity while working. Wires of the rings keep well together with the floor and there must be wires to connect the irons and the floor.在使用兰、绿 LED 时, 作业员必须佩戴静电环、防静电手套、穿防静电服, 静电环须与地面接触良好, 烙铁须接地线。

PREVENTING OVERCURRENT 过流保护:

- 1、 Be not overcurrent. 禁止使用大电流。
- 2、 In order to cooperate LEDs under stable conditions, put protective resisetor in seride. Resistor values can be determined by supplying voltage or current for the LEDs Recommended current is in the range of forward current 5mA-20mA.使用中 加入保护电阻以便配合发光二极管的正常使用。保护电阻可以限制电压或电流不超过发光二极管的正常使用范围。建议使用时的正常电流在 5mA-20mA.

Circuit must be designed so that overvoltage is not applied the LED during on/off switching. Transient or pulse current will damage junction of LED die.在使用发光二极管器件时, 必须先设计电路的电压和电流, 以免 LED 过载, 短暂的过载就可能 导致 LED 发光部分损坏而不能发光。

# Part Number: IE-5WW-C-1F

## ■Reliability Performance 可靠性测试

### (1) TEST ITEMS AND RESULTS 测试项目和结果

Type 类型	Test Item 测试项目	REF Standard 标准	Test Conditions 测试条件	Note 备注	Number of Damaged 测试结果
Environmental Sequence 测试环境次序	Resistance to Soldering Heat (Reflow Soldering) 高温长时间焊接测试		Tsld=230℃,10sec	2times 次	0/22
	Temperature cycle 温度周期	JIS C 7021 (1977)A-4	-20℃ 30min 5min 80℃ 30min	100 cycle	0/100
	Thermal Shock 高低温测试	MIL-STD-107D	-20℃ 15min 80℃ 15min	100cycle	0/100
	High Temperature Storage 高温贮藏测试	JIS C 7021 (1977)B-10	Ta=80℃	1000hrs	0/100
	Temperature Humidity Storage 高湿度贮藏测试	JIS C 7021 (1977)B-11	Ta=60℃ RH=90%	1000hrs	0/100
	Low Temperature Storage 低温贮藏测试	JIS C 7021 (1977)B-12	Ta=-30℃	1000hrs	0/100
Operation Sequence	Life Test 寿命测试	JIS C 7035 (1985)	Ta=25℃ IF=20mA	1000hrs	0/100
	High Humidity Heat Life Test 高温高湿测试		60℃ RH=90% IF=20mA	500hrs	0/100
	Low Temperature Life Test 低温寿命测试		Ta=-20℃ IF=20mA	1000hrs	0/100

### (2).Criteria for Judging The Damage 测试标准:

Item 项目	Symbol 符号	Test Conditions 测试条件	Criteria for Judgment 标准	
			Min	Max
Forward Voltage 正向电压降	VF	IF=20mA		U.S.K*1.2
Reverse current 反向电流	IR	VR=5V		U.S.L*2.2
Luminous Intensity 发射功率	IV	IF=20mA	L.S.L**x0.7	

U.S.L\*:Upper Standard Level

L.S.L\*\*:Lower Dstandard Level

# Part Number: IE-5WW-C-1F

Optical characteristics curves

