

DATA SHEET

Revise History 修订记录

Rev.版本	Descriptions描述	Date日期	Page页
1.0	-	23-10-2009	-
2.0	Renew form续订表格	15-12-2015	-
2.1	Renew form续订表格	10-11-2018	-
2.2	Renew form续订表格	27-12-2021	-
2.3	Renew form续订表格	23-10-2023	-
2.4	Renew form续订表格	10-10-2024	-



Features 特征

- Long operating life. 使用寿命长.
- Low Power Consumption. 低功耗.
- Low voltage DC operated. 低压直流工作.
- RoHS Compliant. 符合 RoHS.
- Moisture sensitivity level: 5a. 湿度敏感性等级: 5a.

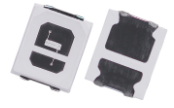

Application 应用

- Traffic light, barricade light, brake light, warning sign, plant growth. 交通灯, 路障灯, 刹车灯, 警告标志, 植物生长.

Part Number 产品型号	Dice Material 芯片材质	Emitted Color 发光颜色	Lens Color 胶体形态
IE-2835UV-HB-CE-0.7	InGaN	Purple	Water Clear

Electro-Optical Characteristics 电光参数 (Ta=25°C)

Parameter 参数	Symbol 符号	Min. 最小值	Typ. 中间值	Max. 最大值	Unit 单位	Test Condition 测试条件
Radiant Flux 辐射通量	Po	40	-	80	mW	IF=60mA
Forward Voltage 正向电压	VF	2.80	3.00	3.60	V	
Radiation Bandwidth 半波宽	$\Delta\lambda$	-	25	-	nm	
Color Rendering Index 显色指数	Ra	-	-	-	-	
CIE Coordinates CIE 坐标	x,y	-				
Peak Wavelength 峰值波长	λ_p	360	365	370	nm	
Dominant Wavelength 主波长	λ_d	-	-	-	nm	
Viewing Angle *1 发光角度	2 θ 1/2	-	120	-	deg	VR=5V
Reverse Current 反向电流	IR	-	-	10	uA	

Notes 备注:

1. 2 θ 1/2 is the o-axis angle where the luminous intensity is 1/2 the peak intensity. 2 θ 1/2 是 0 轴角, 其中发光强度是峰值强度的 1/2.

Absolute Maximum Ratings 绝对最大额定值 (Ta=25°C)

Parameter 参数	Symbol 符号	Max. 最大值	Unit 单位
		Purple	
Power Dissipation 消耗功率	Pd	120	mW
Peak Forward Current *1 脉冲峰值电流	IFP	100	mA
Forward Current 正向电流	IF	60	mA
Human Body Model 人体放电模式	ESD	2000	V
Operating Temperature Range 工作温度	Topr	-40to+85	°C
Storage Temperature Range 贮存温度	Tstg	-40to+90	°C
Reflow Soldering 回流焊	Tsld	260°C for 5 secs	

Notes 备注: 1. Duty Factor=10%, Frequency=1kHz. 占空因数=10%, 频率=1kHz.

Optical & Electrical Characteristics Curves 光电特性曲线

Relative Intensity vs. Wavelength

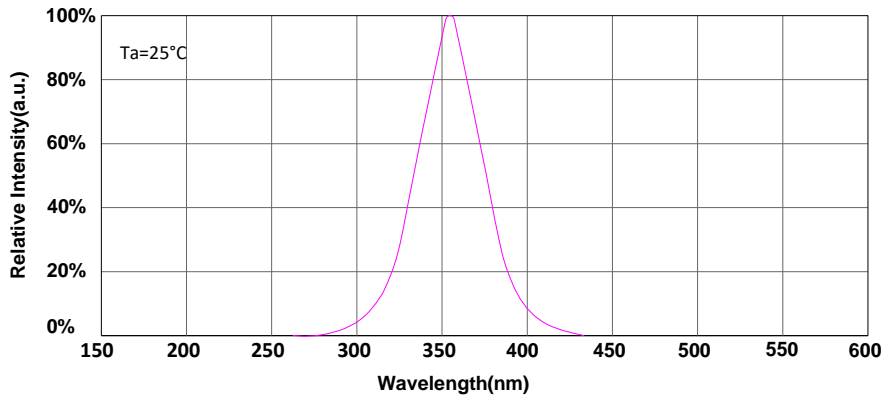

Forward Current vs. Forward Voltage

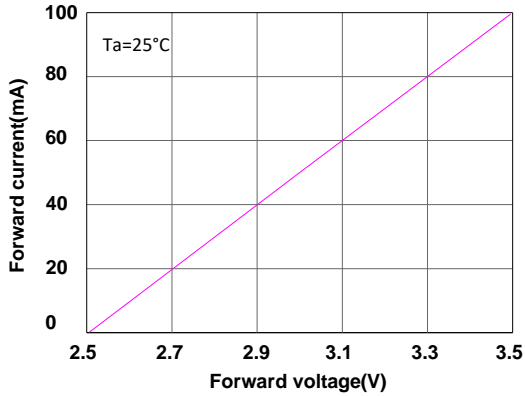

Radiation Power vs. Forward Current

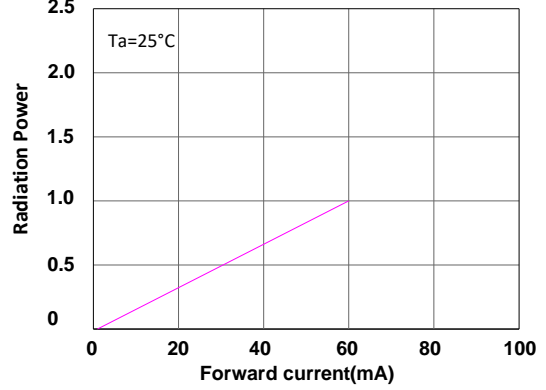

Forward Current Derating Curve

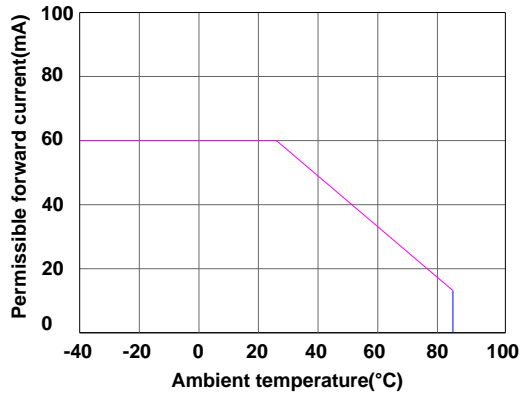

Radiation Power vs. Ambient Temperature

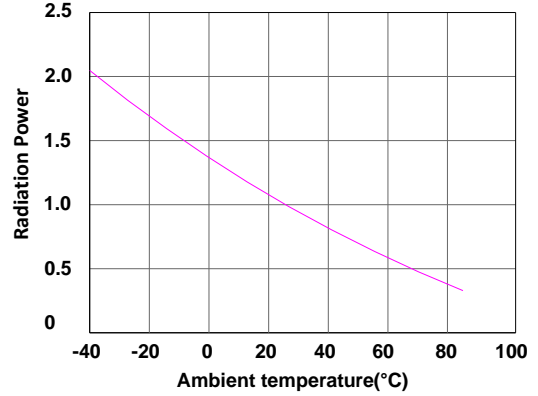

Spatial Distribution

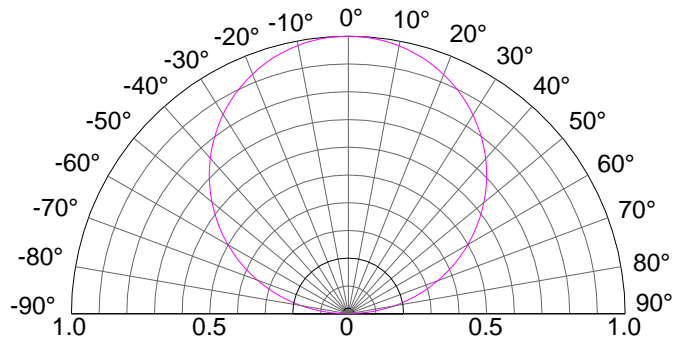

Electro-Optical Characteristics Bin Limits 光电特性分选范围

Bin Range Of Wavelength 波长等级(Unit:nm 单位:nm)

Bin Code 等级码	Min. 最小值	Max. 最大值	Condition 条件
P1	360	365	IF=60mA
P2	365	370	
P3	-	-	
P4	-	-	
P5	-	-	
P6	-	-	

Bin Range Of Radiant Flux 辐射通量等级(Unit:mw 单位:mw)

Bin Code 等级码	Min. 最小值	Max. 最大值	Condition 条件
L1	40	60	IF=60mA
L2	60	80	
L3	-	-	

Bin Range Of Forward Voltage 正向电压等级(Unit:V 单位:V)

Bin Code 等级码	Min. 最小值	Max. 最大值	Condition 条件
V1	2.8	3.0	IF=60mA
V2	3.0	3.2	
V3	3.2	3.4	
V4	3.4	3.6	
V5	-	-	

Notes备注:

1. Radiant Flux measurement tolerance: $\pm 10\%$. 亮度测量公差: $\pm 10\%$.
2. Wavelength measurement tolerance: $\pm 1\text{nm}$. 波长测量公差: $\pm 1\text{nm}$.
3. Forward voltage measurement tolerance: $\pm 0.1\text{V}$. 电压测量公差: $\pm 0.1\text{V}$.

Package Dimension 封装尺寸 (Unit:mm,Tolerance: ±0.20mm 单位:mm,公差:±0.20mm)

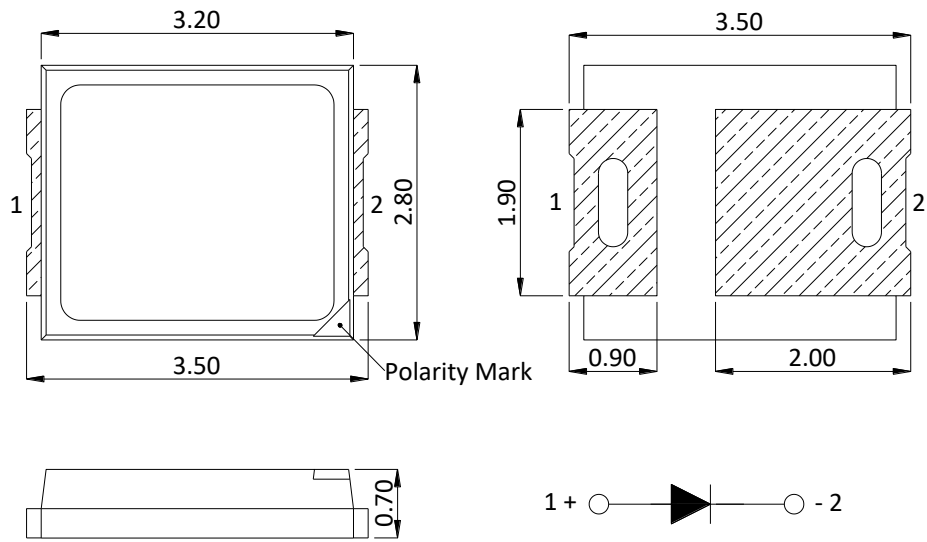

Recommended Soldering Pad Design 推荐焊盘设计 (Unit:mm,Tolerance: ±0.10mm 单位:mm,公差:±0.10mm)

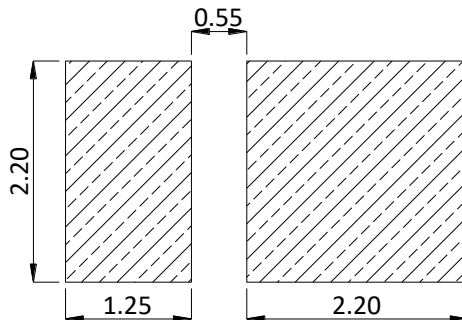

Carrier Tape Dimensions 载带尺寸 (Unit:mm,Tolerance: ±0.10mm 单位:mm,公差:±0.10mm)

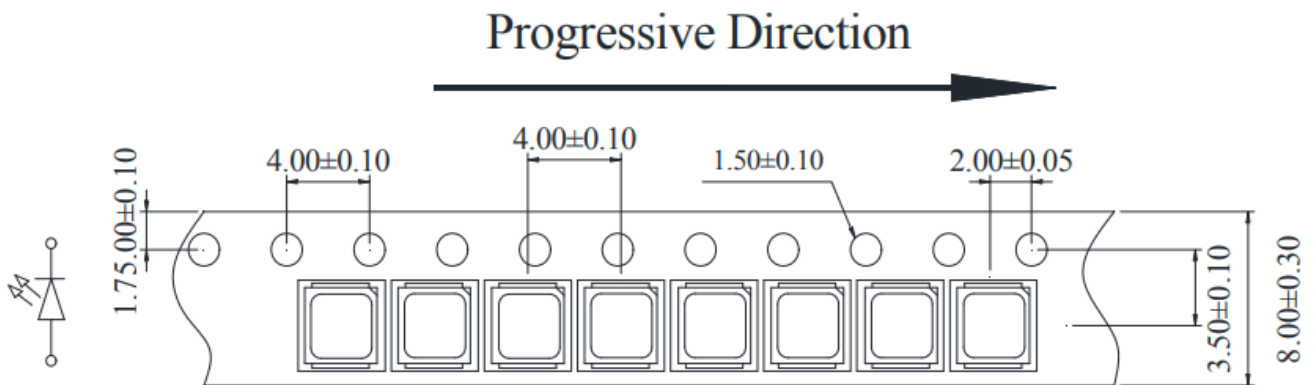

● Loaded quantity 2000 pcs per reel. 每个卷轴装载2000个。

SMT Reflow Soldering Instructions 回流焊说明

Pb-free solder temperature profile 无铅焊温度曲线

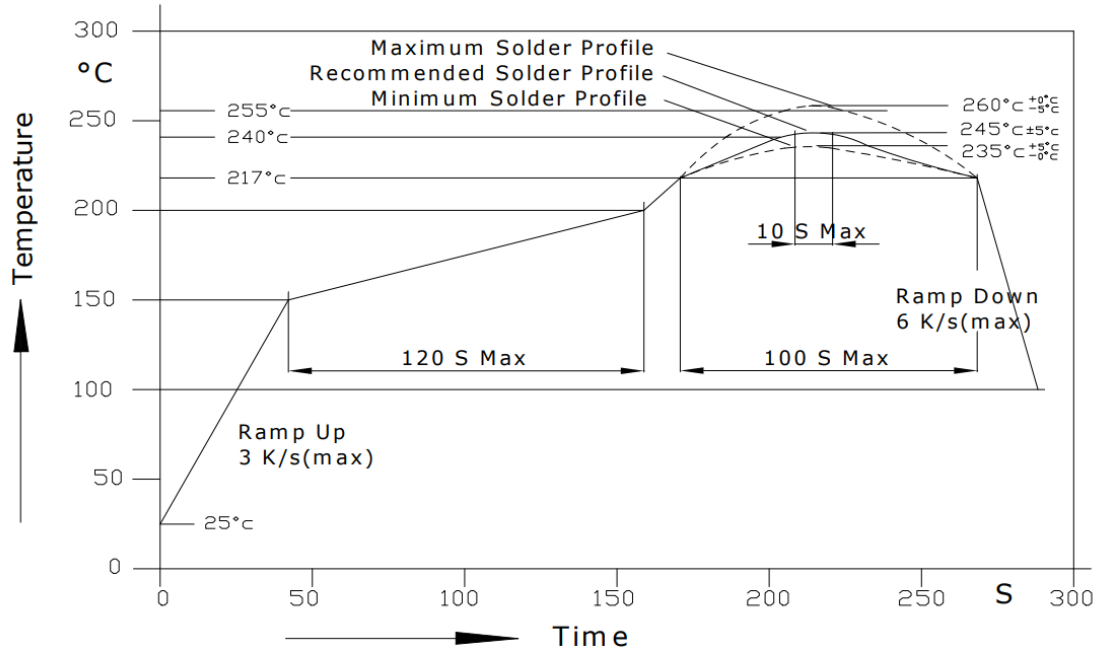

- Reflow soldering should not be done more than two times. 回流焊接不应超过两次.
- When soldering, do not put stress on the LEDs during heating. 焊接时,加热时不要对 LED 施加压力.
- After soldering, do not warp the circuit board. 焊接后,不要扭曲电路板.
- Recommended soldering conditions: 推荐焊接条件:

Reflow soldering		Soldering iron	
Pre-heat	150~200°C	Temperature	300°C Max.
Pre-heat time	120 sec. Max.	Soldering time	3 sec. Max.
Peak temperature	260°C Max.		(one time only)
Soldering time	10 sec. Max.(Max. two times)		

Precautions 注意事项

1. Storage 储存:

- Moisture proof and anti-electrostatic package with moisture absorbent material is used, to keep moisture to a minimum.

防潮防静电包装采用吸湿材料,使水分保持在最低限度.

- Before opening the package, the product should be kept at 30°C or less and humidity less than 60% RH, and be used within a year.

打开包装前,产品应保持在 30°C 或以下,湿度小于 60%RH,并在一年内使用.

- After opening the package, the product should be stored at 30°C or less and humidity less than 10%RH. It is recommended that the product be operated at the workshop condition of 30°C or less and humidity less than 60%RH.

打开包装后,产品应储存在 30°C 或以下,湿度小于 10%RH 的环境中.建议在 30°C 及以下,湿度低于 60%RH 的车间条件下操作.

- If the moisture absorbent material has faded away or the LEDs have exceeded the storage time, baking treatment should be performed based on the following condition: (70±5) °C for 24 hours.

如果吸湿材料已经褪色或 LED 已经超过储存时间,则应根据以下条件进行烘烤处理: (70±5) °C,持续 24 小时.

2. Static Electricity 静电:

- Static electricity or surge voltage damages the LEDs. Damaged LEDs will show some unusual characteristics such as the forward voltage becomes lower, or the LEDs do not light at the low current. All devices, equipment and machinery must be properly grounded. At the same time, it is recommended that wrist bands or anti-electrostatic gloves, anti-electrostatic containers be used when dealing with the LEDs.

静电或浪涌电压会损坏 LED,损坏的 LED 将显示一些不寻常的特性,例如正向电压变低,或者 LED 在低电流下不亮.所有装置、设备和机械必须正确接地.同时,建议在处理 LED 时使用腕带或防静电手套、防静电容器.

3. Vulcanization 硫化:

- LED curing is due to sulfur being in bracket and the +1 price of silver in the chemical reaction generated Ag₂S in the process. It will lead to the capacity of reflecting of silver layer reducing, light color temperature drift and serious decline, seriously affecting the performance of the product. So we should take corresponding measures to avoid vulcanization, such as to avoid using sulphur volatile substances and keeping away from high sulphur content of the material.

LED 固化是由于硫的存在,在化学反应中生成 Ag₂S,导致银层的反射能力下降,光色温漂移和严重性能下降.因此,我们应该采取相应的措施避免硫化,比如避免使用挥发性硫化物,远离高硫含量的材料.

4. Handling Precautions 搬运注意事项:

- Handle the component along the side surfaces by using forceps or appropriate tools.

使用钳子或适当的工具沿着侧面处理部件.

- Do not directly touch or handle the epoxy resin lens surface. It may damage the internal circuitry.

请勿直接触摸或处理环氧树脂镜片表面,它可能会损坏内部电路.

- Do not stack together assembled PCBs containing exposed LEDs. Impact may scratch the epoxy resin lens or damage the internal circuitry.

不要将组装好的含有暴露LED的PCB堆叠在一起,撞击可能划伤环氧树脂透镜或损坏内部电路.