

# Specification for approval

CUSTOMER NAME: \_\_\_\_\_

DIRECTOR: \_\_\_\_\_ TITLE: \_\_\_\_\_

CUSTOMER PART NO.: \_\_\_\_\_

PART NUMBER: IE-2018RGB-F-ST-CE REVISION: 2.0

ISSUE DATE: 2014/01/08 RETURN DATE:  / /

## CUSTOMER'S PROPOSAL

- AGREE
- DISAGREE

REASON

\_\_\_\_\_  
\_\_\_\_\_

CUSTOMER SIGNATURE: \_\_\_\_\_



## ● APPLICATION

### ELECTRICAL CHARACTERISTICS ( VDD=3V , TA=25°C unless otherwise specified )

Characteristic	Symbol	Min.	Typ.	Max.	Unit	Remarks
Operating Voltage	V <sub>DD</sub>	2.0	3.0	3.5	V	
Operating Current	I <sub>DD</sub>	-	0.1	0.2	mA	No load
Driving Current	I <sub>OL</sub>	-	25	-	mA	@V <sub>bs</sub> =1.0V
Operating Temperature	Temp.	0	25	60	°C	

### Product size

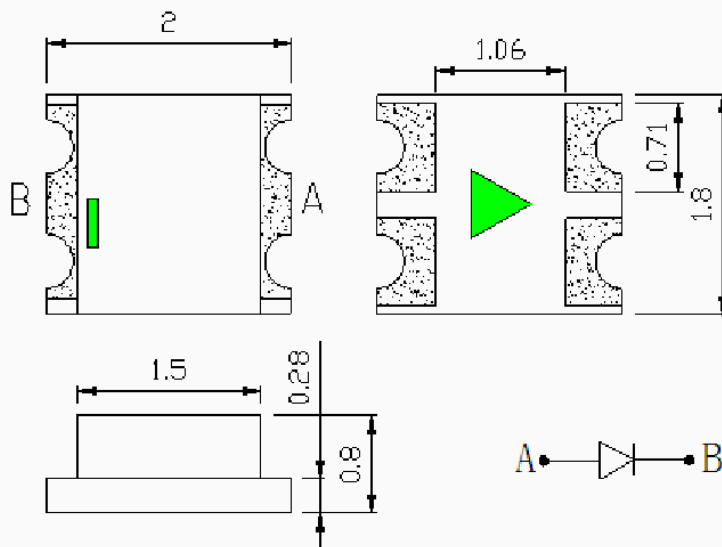

## Recommended Soldering Pattern

(Units : mm)

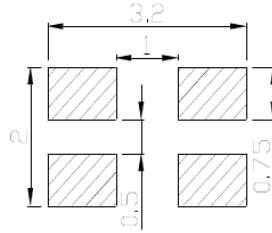

## Tape Specifications

(Units : mm)

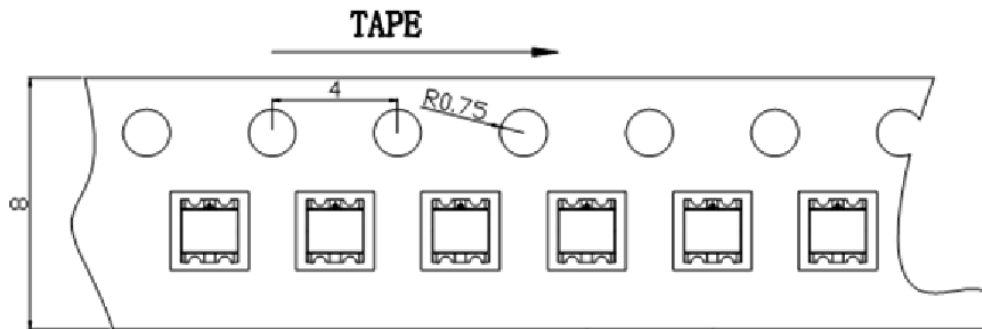

**Package: 2000 pcs/reel**

Remarks:

If special sorting is required (e.g. binning based on forward voltage, luminous intensity / luminous flux or wavelength),

the typical accuracy of the sorting process is as follows:

1. Wavelength: +/-1nm
2. Luminous Intensity / Luminous Flux: +/-15%
3. Forward Voltage: +/-0.1V

**Note: Accuracy may depend on the sorting parameters.**

## Suggest welding way

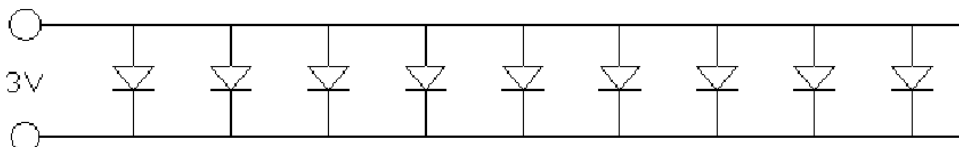

## RELIABILITY

### Test Items and Results

1		JEITA ED-4701	-40°C ~ 25°C ~ 100°C ~ 25°C 30      5      30 5	100	50	0/50
2		MIL-STD-202G	-40°C ~ 100°C 15      15	500	50	0/50
3		JEITA ED-4701 200 201	T <sub>a</sub> =100°C	1000	50	0/50
4		JEITA ED-4701 200 201	T <sub>a</sub> =-40°C	1000	50	0/50
5			T <sub>a</sub> =25±5°C I <sub>F</sub> =20mA	1000	50	0/50
6			T <sub>a</sub> =60°C RH=85% I <sub>F</sub> =20mA	1000	50	0/50
7		JEITA ED-4701 300 303	T <sub>sol</sub> =235°C±5°C,5	5	10	0/10
8		JEITA ED-4701 300 301	T <sub>sol</sub> =260°C,10 35°C 95%RH 96	10	10	0/10

## Cautions

### (1) Soldering Conditions

Number of reflow process shall be less than 2 times and cooling process to normal temperature is required between first and Second soldering process.

(Recommended soldering conditions)

Reflow Soldering			Temperature	350° C Max. 3 sec. Max. (one time only)
	Lead Solder	Lead-free Solder		
Pre-heat	140 ~ 160° C	180 ~ 200° C		
Pre-heat time	120 sec. Max.	120 sec. Max.		
Peak temperature	230° C Max.	260° C Max.		
Soldering time	10 sec. Max.	10 sec. Max.		
Condition				

(Lead Solder)

(Lead-Free Solder)

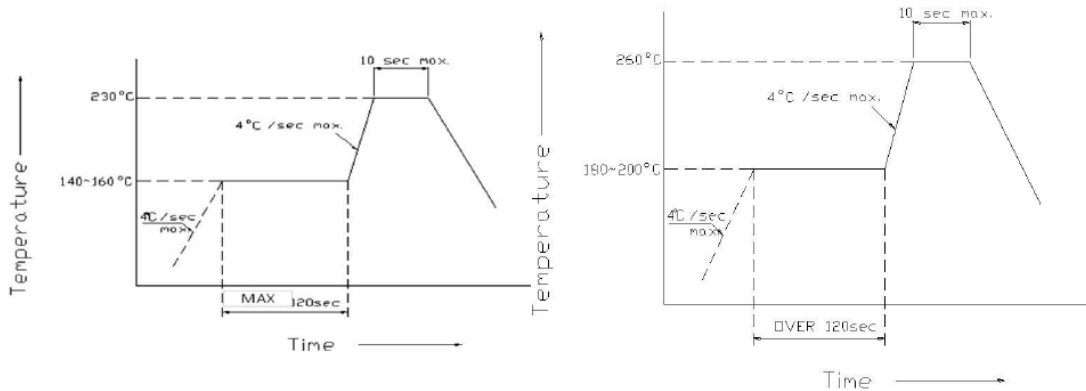

### Recommended Soldering Pattern

(Units : mm)

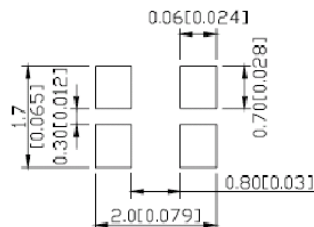

## Static Electricity

It is recommended that a wrist band or an anti-electrostatic glove be used when handling the LEDs.

All devices, equipment and machinery must be properly grounded.

2.0V Damaged LEDs will show some unusual characteristics such as the forward voltage becomes lower, or the LEDs do not light at the low current. Criteria : (VF > 2.0V at IF=0.5mA)

### (3) Moisture Proof Package

It is recommended that moisture proof package be used .

### (4)

Cautions:

#### 4.1.

Please check if there is air leak before opening the package, if so, please return the goods back to take drying process for later using.

#### 4.2

Products can be used within 15days after packaging, after that, they must be:

##### 4.2.1

Soldered within 24 hrs

##### 4.2.2

Used in the condition: 30°C within and 60%RH below

##### 4.2.3

Stored in 30%RH for moisture below.

#### 4.3.

Products cannot be used for and over 15days after being packaged unless opening the package and take drying our process in 85°C/6H.

#### 4.4.

Products not be used for or over 60days after being packaged please return back to take drying out and packaging process for forward using.

#### 4.5.

Products not be used after opening the package need to be dried out for 85°C/6H