

Approve Sheet

/Product	LED	
/Part Number	3014	
	IE-3014B-ST-R-A01-Y	
/Issue Date		
/customer specification		
/Customer		
(mcd)	B:300-500mcd	
/VF (V)	B:3.0-3.4V	
/CRI		
/remarks		
/Maker		
Prepared	Checked	Customer Confirmation

PackageDimensions:

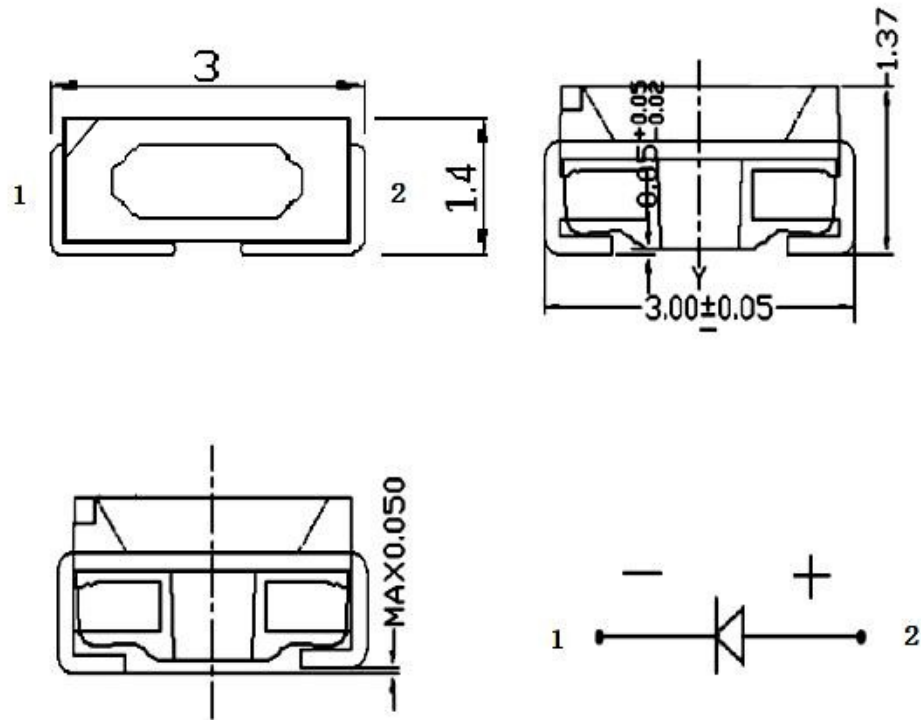

Notes

All dimensions are in millimeters (inches).

Tolerance is $\pm 0.25\text{mm}$ (.010") unless otherwise noted.

Protruded resin under flange is 1.0mm (.04") max.

Lead spacing is measured where the leads emerge from the package.

Specifications are subject to change without notice.

Absolute Maximum Ratings at TA=25°C

Parameter	Valce	Unit
Power Dissipation	B	mW
	100	
Pulsed Forward Current (1/10 Duty Cycle, 0.1ms Pulse width)	60	mA
Continuous Forward Current	30	mA
Derating Linear From 50°C	0.4	mA/°C
Reverse Voltage	5	V
Operation Temperature Range	-30°C to +80°C	
Storage Temperature Range	0°C to +40°C	
Lead Soldering Temperature [4mm (.157") From Body](焊接温度)	260°C for 5 Seconds	

Electrical / Optical Characteristics at TA=25°C

Parameter	Symbol	Min	Typ.	Max	Unit	Test Condition	
Luminous Intensity	IV	B	300	--	500	mcd	IF=30mA
Viewing Angle	2 θ 1/2	110	--	120	deg	Note 2	
wave length(λd)	B		460	--	465	nm	IF=30mA
			465		470		
Forward Voltage (R)	VF	B	3.0	--	3.2	V	IF=30mA
			3.2		3.4		
Reverse Current	IR	--	--	5	μA	VR=5V	

Notes: Luminous intensity is measured with a light sensor and filter combination that approximates the CIE

(Commission International De L'Eclairage) eye-response curve. 1/2 is the off-axis angle at which the luminous intensity is half the axial luminous and intensity. The dominant wavelength, λd is derived from the CIE chromaticity diagram and represents the single wavelength which defines the color of the device. The IV guarantee should be added ±15%.

INTENSITY BIN LIMIT (IF=30mA)

Blue

BinCode	Min(mcd)	Max(mcd)
A	300	500

COLOR BIN LIMIT(IF=30mA)

Blue

BinCode	Min(nm)	Max(nm)
A	460	465
B	465	470

Optical Characteristics

光谱曲线图

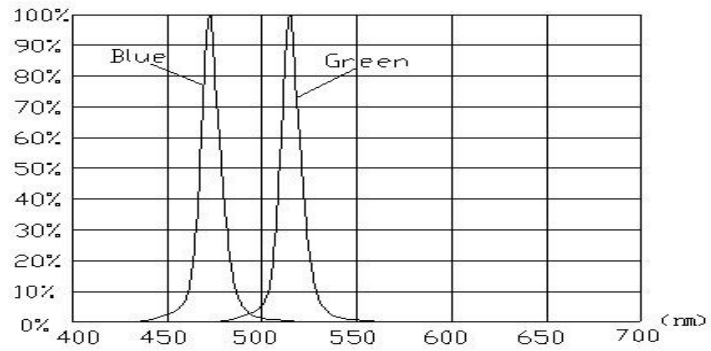

电压电流关系曲线图

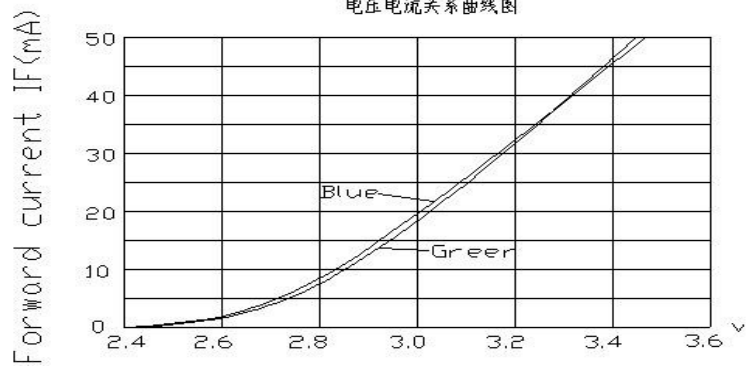

亮度/流明与温度的关系曲线图

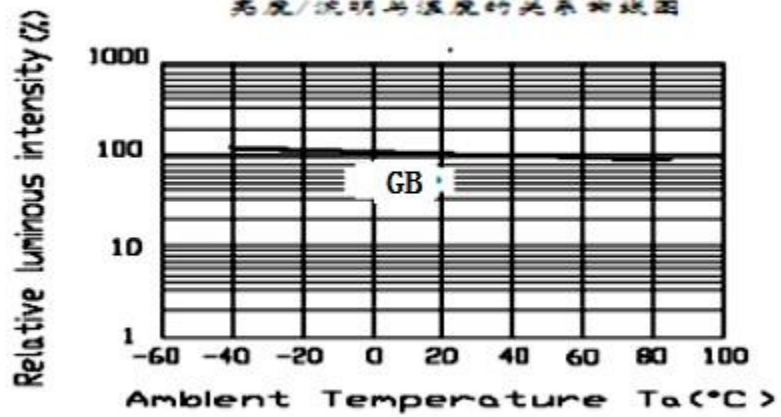

电流与温度关系曲线图

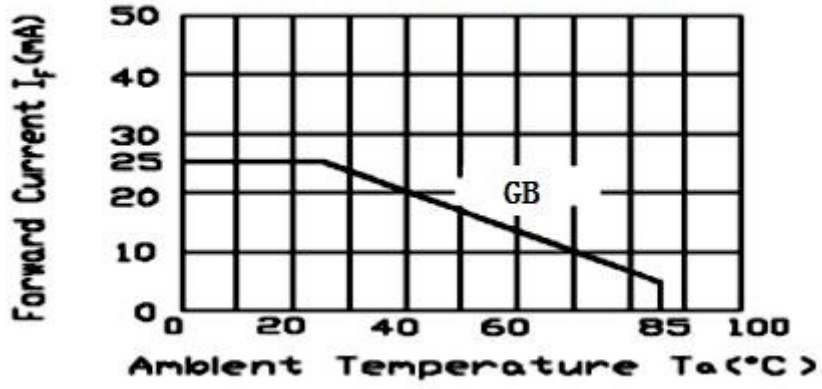

发光角度图

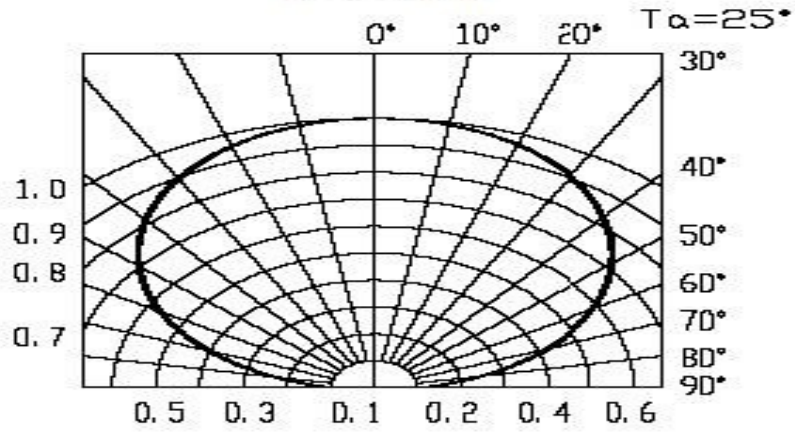

Reflow Soldering Instructions

Number of reflow process shall be less than 2 times and cooling process to normal temperature is required between first and Second soldering process.

1>Lead Solder

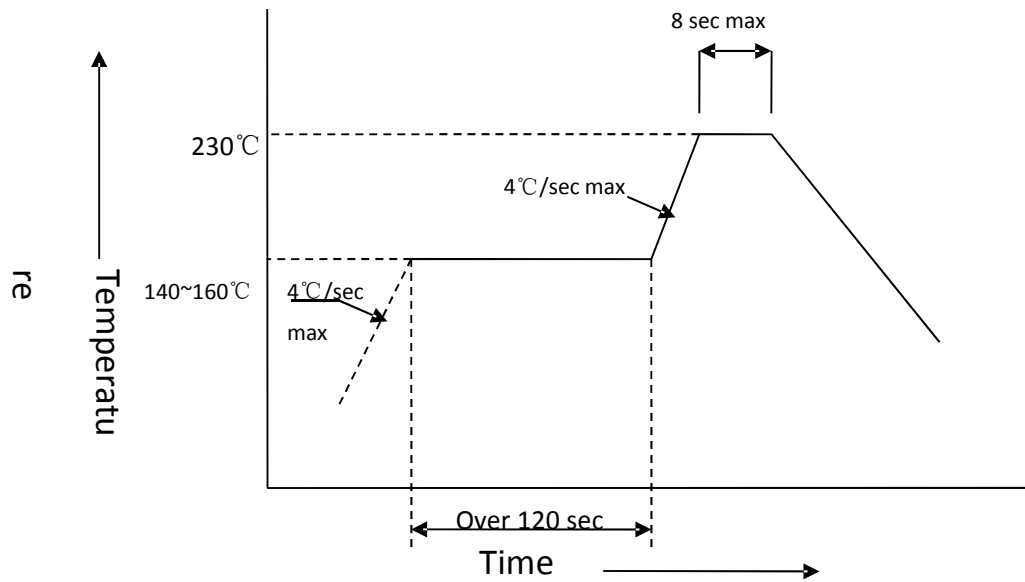

2>Lead-Free Solder

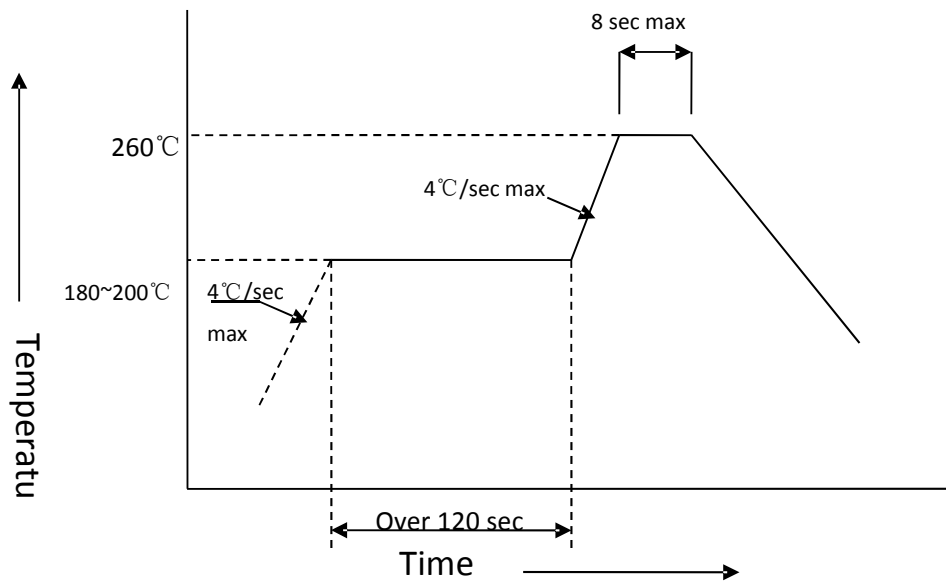

Recommended Soldering Pattern

<Units:mm>

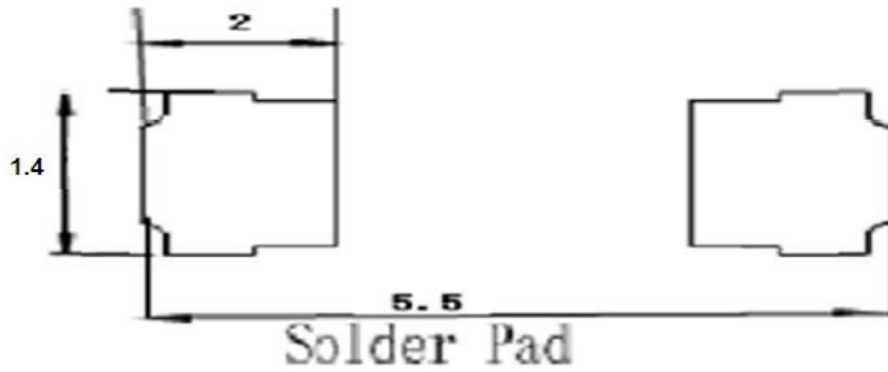

Method of Taping / Polarity and Orientation

Packing unit 1000/reel, $\varnothing 180$ mm

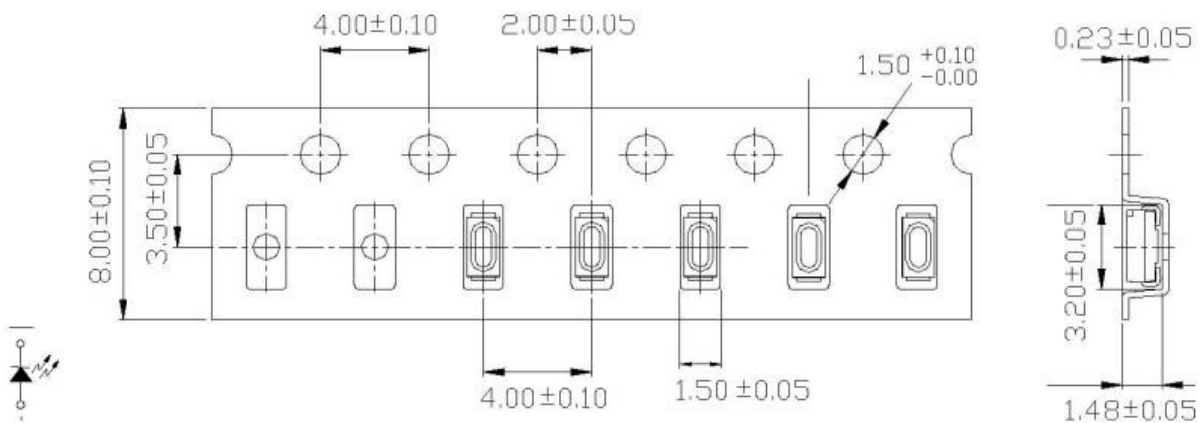

Adhesion Strength of Cover Tape : Adhesion strength to be 0.1– 0.7N when the cover tape is turned off from the carrier at 10° angle to be the carrier tape.

SMD LED

