

Specification for approval

CUSTOMER NAME: _____

DIRECTOR: IE-3215G-SB-L-RM-C TITLE: _____

CUSTOMER PART NO.: _____

PART NUMBER: _____ REVISION: 2.0

ISSUE DATE: 2014-9-3 RETURN DATE: / /

We are please in sending you herewith our specification and drawings for your approval.
Please return to us one copy "For Approval" with your approved signatures.

CUSTOMER'S PROPOSAL

- AGREE
- DISAGREE

REASON _____

CUSTOMER SIGNATURE: _____

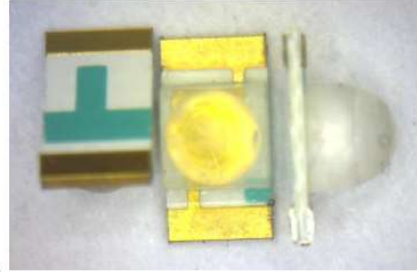

Features

- _3.2mmX1.6mm SMT LED, 1.85mm THICKNESS.
- _LOW POWER CONSUMPTION.
- _WIDE VIEWING ANGLE.
- _IDEAL FOR BACKLIGHT AND INDICATOR.
- _VARIOUS COLORS AND LENS TYPES AVAILABLE.
- _PACKAGE: 3000PCS / REEL.
- _RoHS COMPLIANT.

Description

The Green source color devices are made with AlGaInP on GaAs substrate Light Emitting Diode.

Applications

- 1.Mobile phone Keypad indicator and backlight.
- 2.Flat backlight for LCD, switch and symbol.
- 3.Toys.

Package Dimensions

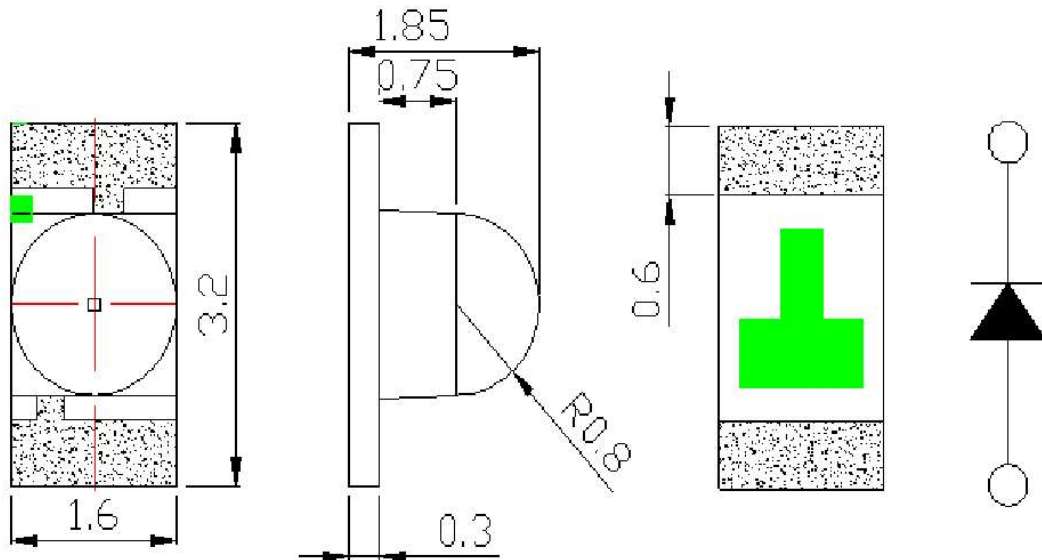

Notes:

1. All dimensions are in millimeters (inches).
2. Tolerance is $\pm 0.1(0.004)$ unless otherwise noted.
3. Specifications are subject to change without notice.

Selection Guide

Part No.	Dice	Lens Type	Iv (mcd) @ 20mA		Viewing Angle
			Min.	Typ.	2 θ 1/2
IE-3215G-SB-L-RM-C	Yellow green	WATER CLEAR	100	150	35

Note:

1. θ1/2 is the angle from optical centerline where the luminous intensity is 1/2 the optical centerline value.

Electrical / Optical Characteristics at TA=25°C

Symbol	Parameter	Device	Mix	Max.	Units	Test Conditions
λpeak	Peak Wavelength	Yellow green	566	572	nm	IF=20mA
λD	Dominant Wavelength	Yellow green			nm	IF=20mA
Δλ1/2	Spectral Line Half-width	Yellow green	30		nm	IF=20mA
C	Capacitance	Yellow green	15		pF	VF=0V;f=1MHz
VF	Forward Voltage	Yellow green	1.9	2.2	V	IF=20mA
IR	Reverse Current	Yellow green		10	uA	VR = 5V

Absolute Maximum Ratings at TA=25°C

Parameter	Yellow green	Units
Power dissipation	75	mW
DC Forward Current	25	mA
Peak Forward Current [1]	80	mA
Reverse Voltage	5	V
Operating/Storage Temperature	40°C To +85°C	

Note:

1. 1/10 Duty Cycle, 0.1ms Pulse Width.

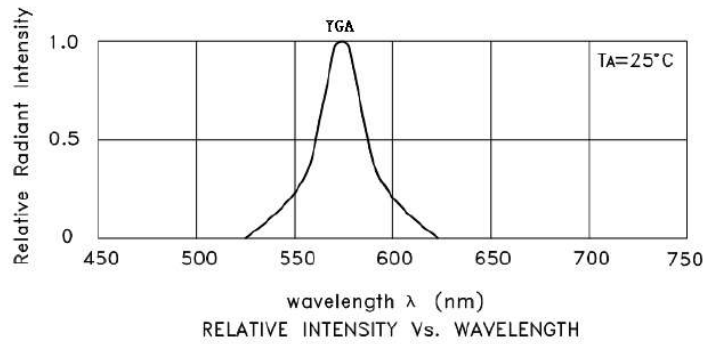

Yellow green

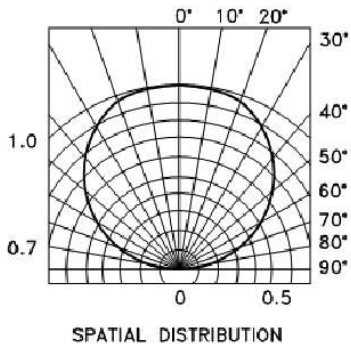
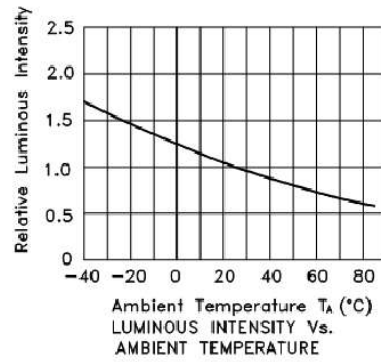
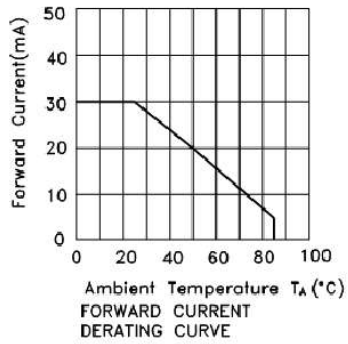
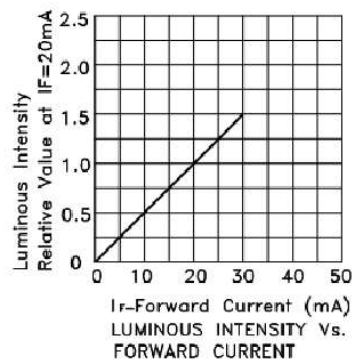
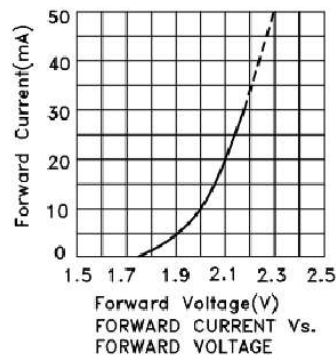

RELIABILITY

Test Items and Results

1		JEITA ED-4701	-40°C ~ 25°C ~ 100°C ~ 25°C 30 5 30 5	100	50	0/50
2		MIL-STD-202G	-40°C ~ 100°C 15 15	500	50	0/50
3		JEITA ED-4701 200 201	T _a =100°C	1000	50	0/50
4		JEITA ED-4701 200 201	T _a =-40°C	1000	50	0/50
5			T _a =25±5°C I _F =20mA	1000	50	0/50
6			T _a =60°C RH=85% I _F =20mA	1000	50	0/50
7		JEITA ED-4701 300 303	T _{sol} =235°C±5°C,5	5	10	0/10
8		JEITA ED-4701 300 301	T _{sol} =260°C,10 35°C 95%RH 96	10	10	0/10

5. Cautions

(1) Soldering Conditions

Number of reflow process shall be less than 2 times and cooling process to normal temperature is required between first and Second soldering process.

(Recommended soldering conditions)

Reflow Soldering				
Pre-heat Pre-heat time Peak temperature Soldering time Condition	Lead Solder	Lead-free Solder	Temperature Soldering time	350° C Max. 3 sec. Max. (one time only)
	140 ~ 160° C 120 sec. Max. 230° C Max. 10 sec. Max.	180 ~ 200° C 120 sec. Max. 260° C Max. 10 sec. Max.		

(Lead Solder)

(Lead-Free Solder)

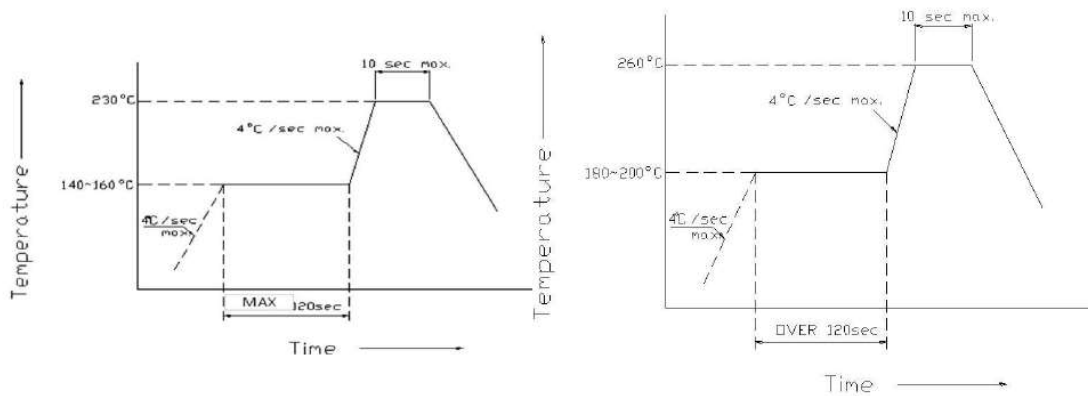

Recommended Solderir
(Units : mm)

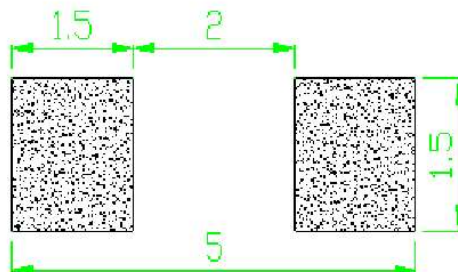

(2) Static Electricity

It is recommended that a wrist band or an anti-electrostatic glove be used when handling the LEDs.

All devices, equipment and machinery must be properly grounded.

2.0V Damaged LEDs will show some unusual characteristics such as the forward voltage becomes lower, or the LEDs do not light at the low current. Criteria : (VF > 2.0V at IF=0.5mA)

(3) Moisture Proof Package

It is recommended that moisture proof package be used .

(4)

Cautions:

4.1.

Please check if there is air leak before opening the package, if so, please return the goods back to take drying process for later using.

4.2

Products can be used within 15days after packaging, after that, they must be:

4.2.1

Soldered within 24 hrs

4.2.2

Used in the condition: 30°C within and 60%RH below

4.2.3

Stored in 30%RH for moisture below.

4.3.

Products cannot be used for and over 15days after being packaged unless opening the package and take drying our process in 85°C/6H.

4.4.

Products not be used for or over 60days after being packaged please return back to take drying out and packaging process for forward using.

4.5.

Products not be used after opening the package need to be dried out for 85°C/6H

PACKAGING

The LEDs are packed in cardboard boxes after taping.

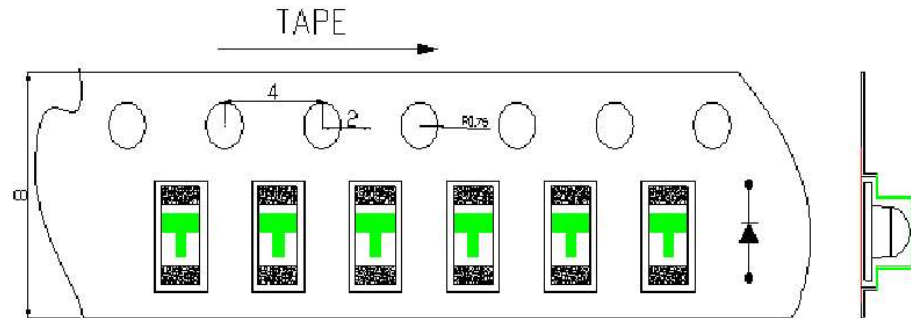

Reel Dimensions

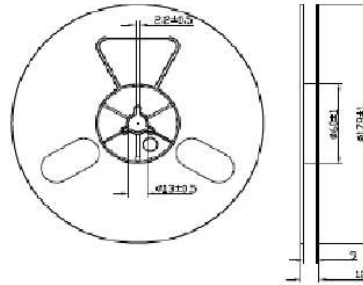

Moisture Resistant Packaging

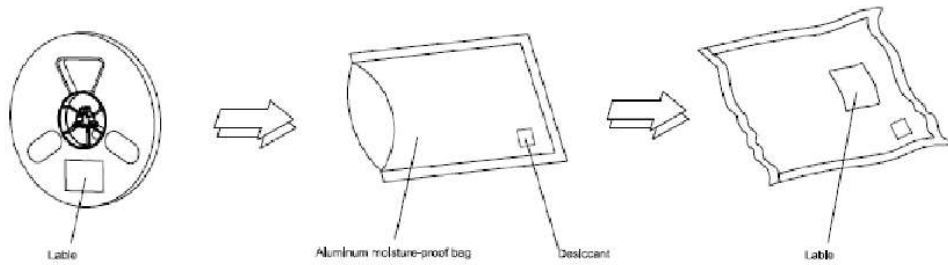

Note: The tolerances unless mentioned is $\pm 0.1\text{mm}$, Unit: mm