SPECIFICATION

IE-MX-1319CH07R24-C0-1

For Customer's Acceptance:

Approved By	Comment		
PREPARED	CHECKED	VERIFIED BY QA DEPT	VERIFIED BY R&D DEPT

1. General Specifications

IE-MX-1319CH07R24-C0-1 is a TFT-LCD module. It is composed of a TFT-LCD panel, driver IC, FPC, a back light unit. The 5.0" display area contains 1024(RGB) x600 pixels and can display up to 16.7M colors. This product accords with ROHS

Item	Contents	Unit	Note
LCD Type	a-Si TFT	-	
Display color	16.7M		1
Viewing Direction	FREE	O'clock	
Gray Scale Inversion	-	O'clock	
Pixel Configuration	RGB Vertical Stripe		
Pixel Pitch	0.1055x0.108	mm	
Display Mode	Transmissive Normally Black		
Resolution	1024×RGB×600	dots	
Module size	120.7*75.8*2.9	mm	2
Active Area(W×H)	108.03*64.8	mm	
Backlight	18-LEDs (white)	pcs	
Brightness(LCM)	500	cd/m ²	TYP
Interface	TTL-24bit	-	

environmental criterion.

Note 1: Color tune is slightly changed by temperature and driving voltage.

Note 2: Without CTP, Without FPC and Solder.

Note 3: LCM weight tolerance: ±5%

2.Outline Drawing

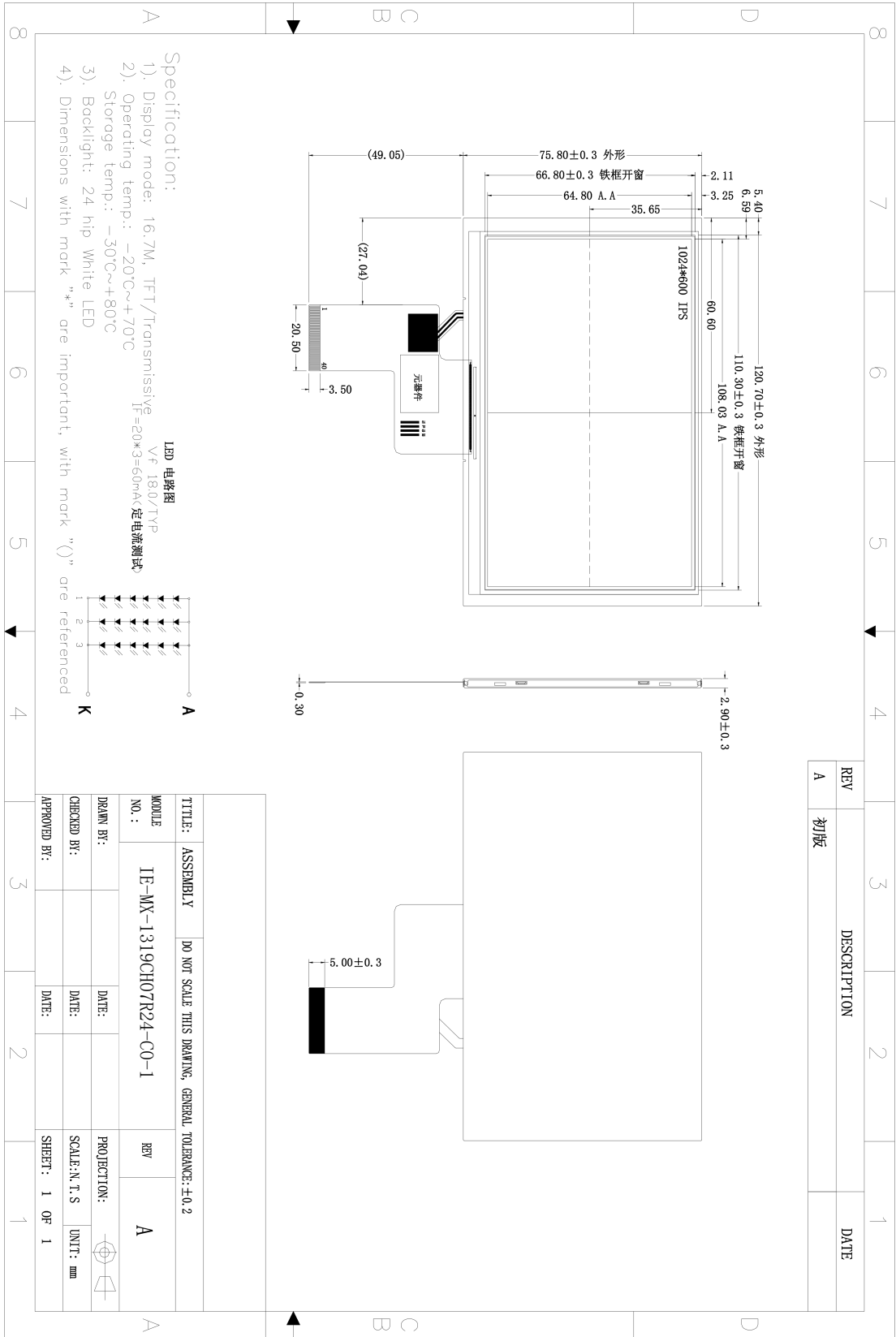

Rev	Nature of Modification	DATE
01	初版	2017/09/01

FRONT VIEW

SIDE VIEW

BACK VIEW

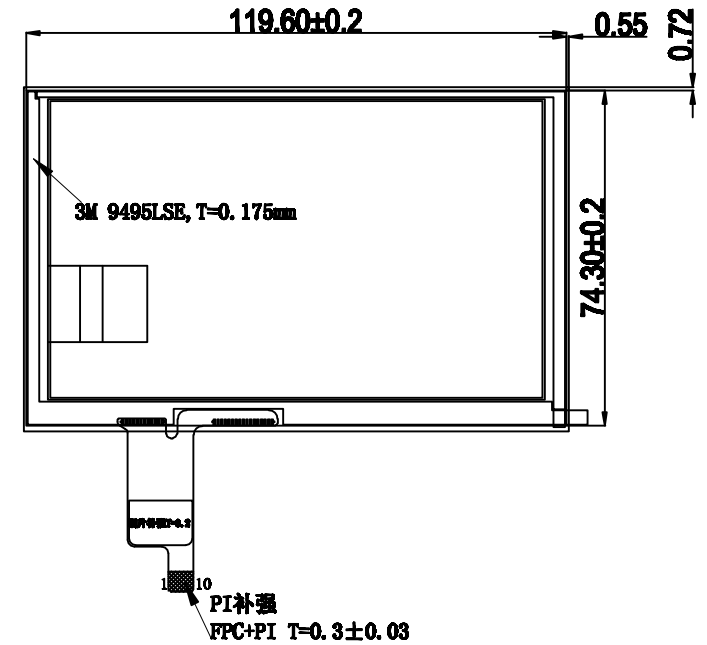
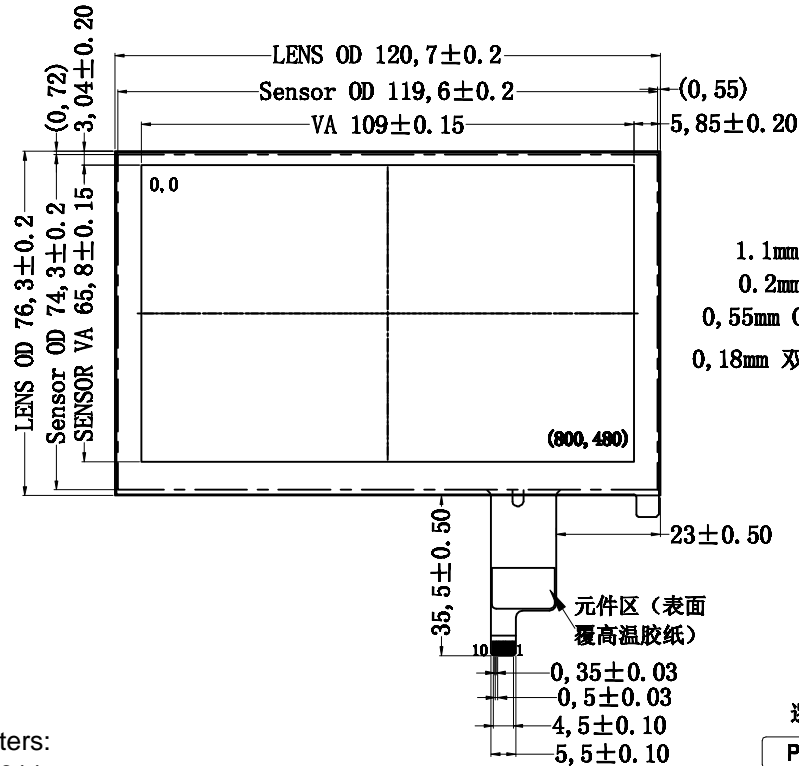

Parameters:

- IC:GT911
- Working volt.:2.8-3.3V
I2C communication voltage:2.8V-3.3V
- Transparency rate > 80%
- Surface hardness: 6H
- Working temp.: -10 to 60 degree, < 90%RH
- Storage temp.: -20 to 70 degree, < 90%RH
- Unmarked tolerance +/- 0.2mm
- ROHS compliance

逻辑定义

PIN	定义
1	VSS
2	VDD
3	SCL
4	VSS
5	SDA
6	VSS
7	/RST
8	NC
9	INT
10	VSS

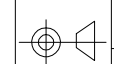
SCALE: 1 : 1 NOT TO SCALE			
PAGE: 1 OF 1			
GENERAL TOL. 0.50mm	UNITS MM		
APPROVALS	DATE		
APP:			
CHK:			
DWN: YANHAI	2017-09-01		
			
		CUSTOMER NO.:	
		DATE:	2017-09-01

3. Absolute Maximum Ratings($T_a=25^{\circ}\text{C}$)

3.1 Electrical Absolute Maximum Ratings.($V_{ss}=0\text{V}$, $T_a=25^{\circ}\text{C}$)

Parameter	Symbol	Min	Typ	Max	Unit	Note
Power supply	DVDD	-0.3	-	3.96	V	
Operating Temperature	TOP	-20	-	70	$^{\circ}\text{C}$	
Storage Temperature	TST	-30	-	80	$^{\circ}\text{C}$	

Notes:

1. If the module is above these absolute maximum ratings. It may become permanently damaged. Using the module within the following electrical characteristic conditions are also exceeded, the module will malfunction and cause poor reliability.
2. $V_{CC} > V_{SS}$ must be maintained.
3. Please be sure users are grounded when handing LCD Module

3.2 Environmental Absolute Maximum Ratings.

Item	Storage		Operating		Note
	MIN.	MAX.	MIN.	MAX.	
Ambient Temperature	-30°C	80°C	-20°C	70°C	1,2

1. The response time will become lower when operated at low temperature.
2. Background color changes slightly depending on ambient temperature.

The phenomenon is reversible.

4. Electrical Specifications

4.1 LCM Electrical characteristics(V_{SS}=0V ,T_a=25°C)

Parameter	Symbol	Min	Typ	Max	Unit	Note	
Power supply	DVDD	2.8	3.3	3.6	V		
Input voltage	'H'	V _{IH}	0.8V _{DVDD}	-	V _{DVDD}	V	
	'L'	V _{IL}	V _{SS}	-	0.2V _{DVDD}	V	
Output voltage	'H'	V _{OH}	0.9V _{DVDD}	-	V _{DVDD}	V	
	'L'	V _{OL}	V _{SS}	-	0.1V _{DVDD}	V	

4.2 LED backlight specification(V_{SS}=0V ,T_a=25°C)

Item	Symbol	Condition	Min	Typ	Max	Unit	Note
Supply voltage	V _f	-	16.8	18	20.4	V	1
Supply current	I _f	-	-	60	-	mA	2
Number of LED	-	6Sx3P	-	18	-	Piece	
Power Consumption	-	-	-	1080	-	mW	
LED life time	-	-	30000	-	-	Hrs	

Note:1: V_{LED}=V_{LED}(+)-V_{LED}(-).

2:The current of LED is 20mA.

A LED drive in constant current mode is recommended.

4.3 Interface Signals

No.	Symbol	Function	Remarks
1	LED_K	Backlight cathode	
2	LED_A	Backlight anode	
3	GND	Power ground	
4	DVDD	Power Supply for Analog Circuit 3.3V	
5~12	R0~R7	Red data bus	
13~20	G0~G7	Green data bus	
21~28	B0~B7	Blue data bus	
29	GND	Power ground	
30	DCLK	TTL clock input pin	
31	DISP	Standby mode select pin, Normal mode =H	
32	HSYNC	Horizontal SYNC signal	
33	VSYNC	Vertical SYNC signal	
34	DE	Date enable signal	
35	NC	No connection	
36	GND	Power ground	
37	XR	Touch panel control pin	
38	YD	Touch panel control pin	
39	XL	Touch panel control pin	
40	YU	Touch panel control pin	

5. Optical Characteristics

Item	Symbol	Condition	Min.	Typ.	Max.	Unit	Note
Brightness	Bp	$\theta=0^\circ$	450	500	-	cd/m ²	1
Uniformity	ΔBp	$\Phi=0^\circ$	75	80	-	%	1,2
Viewing Angle	3:00	Cr \geq 10	80	85	-	Deg	3
	6:00		80	85	-		
	9:00		80	85	-		
	12:00		80	85	-		
Contrast Ratio	Cr	$\theta=0^\circ$	1000	1200		-	4
Response Time	T _r +T _f	$\Phi=0^\circ$		25	35	ms	5
Color of CIE Coordinate	W	x	-0.04	0.300	+0.04	-	1,6
		y		0.340		-	
	R	x		0.642		-	
		y		0.340		-	
	G	x		0.271		-	
		y		0.559		-	
	B	x		0.143		-	
		y		0.174		-	
	Color Gamut					50	

Note: The parameter is slightly changed by temperature, driving voltage and material

Note 1: The data are measured after LEDs are turned on for 5 minutes. LCM displays full white.

The brightness is the average value of 9 measured spots. Measurement equipment PR-705 (Φ 8mm)

Measuring condition:

- Measuring surroundings: Dark room.
- Measuring temperature: Ta=25°C.
- Adjust operating voltage to get optimum contrast at the center of the display.
- Measured value at the center point of LCD panel after more than 5 minutes while backlight turning on.

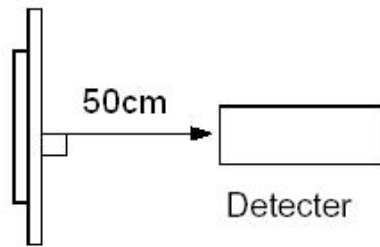

Note 2: The luminance uniformity is calculated by using following formula.

$$\Delta Bp = Bp (\text{Min.}) / Bp (\text{Max.}) \times 100 (\%)$$

$Bp (\text{Max.})$ = Maximum brightness in 9 measured spots

$Bp (\text{Min.})$ = Minimum brightness in 9 measured spots.

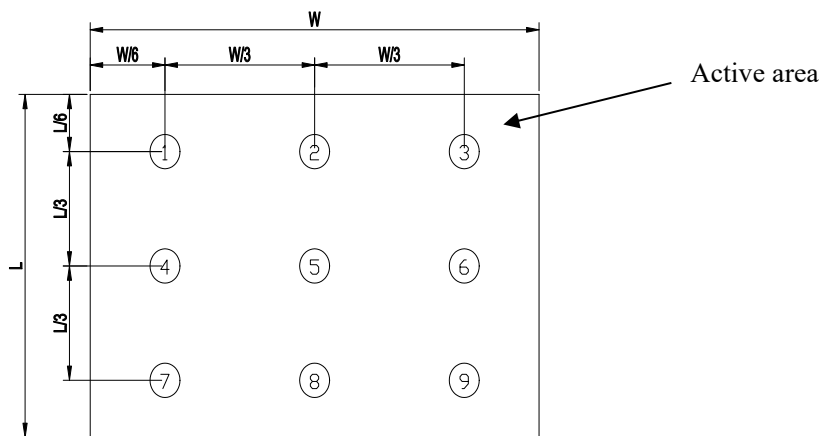

Note 3: The definition of viewing angle:

Refer to the graph below marked by θ and ϕ

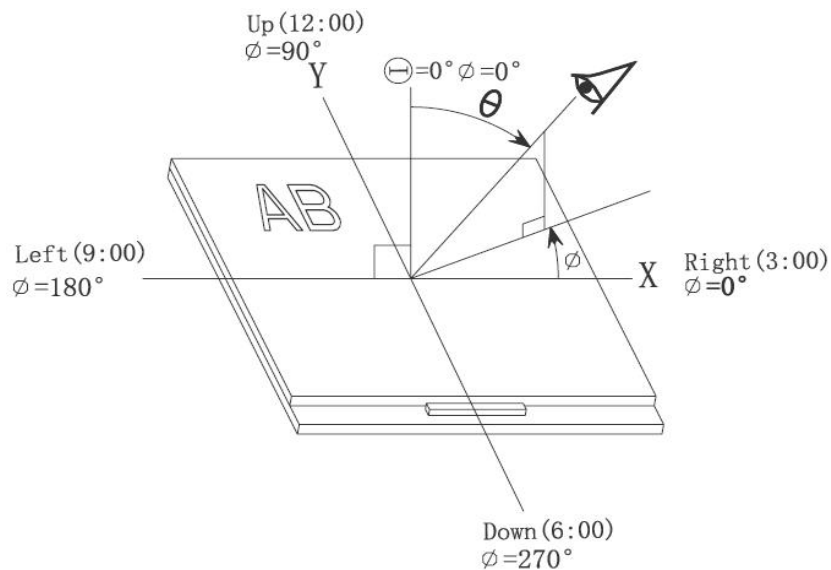

Note 4: Definition of contrast ratio.(Test LCD using DMS501)

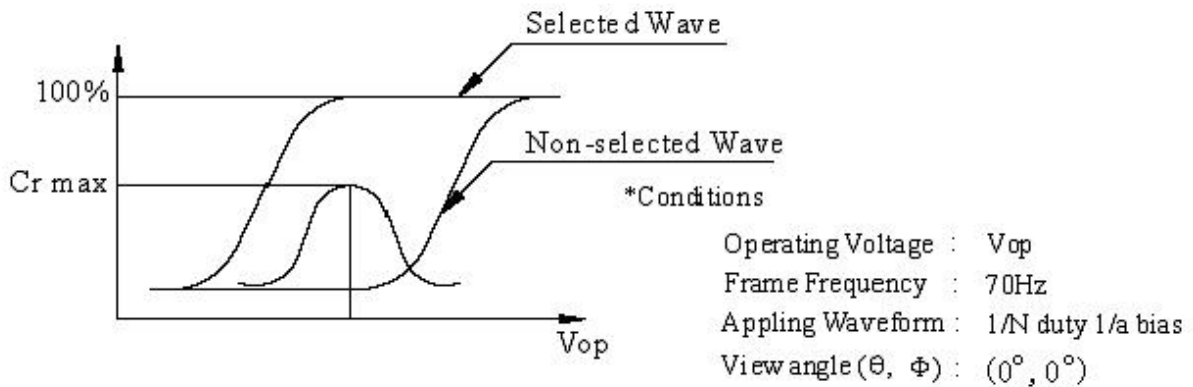

$$\text{Contrast ratio}(Cr) = \frac{\text{Brightness of selected dots}}{\text{Brightness of non-selected dots}}$$

Note 5: Definition of Response time. (Test LCD using DMS501):

The output signals of photo detector are measured when the input signals are changed from “white” to “black”(T_f) and from “black” to “white k”(T_r), respectively. The response time is defined as the time interval between the 10% and 90% of amplitudes. Refer to figure as below.

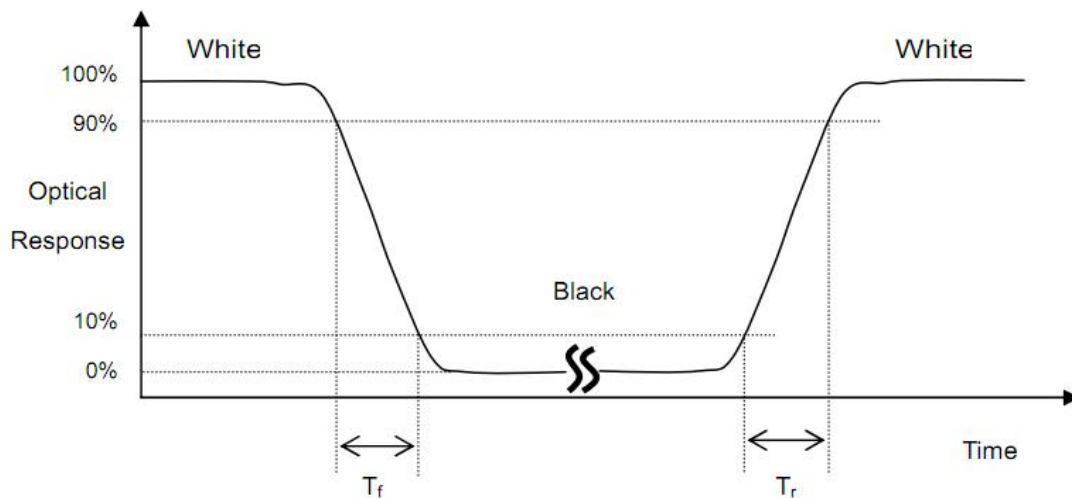

The definition of response time

Note 6: Definition of Color of CIE Coordinate and NTSC Ratio.

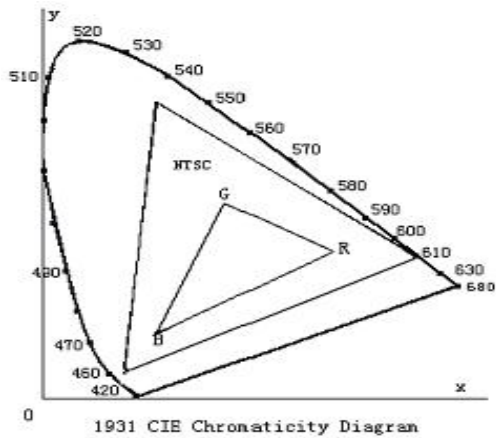

Color gamut:

$$S = \frac{\text{area of RGB triangle}}{\text{area of NTSC triangle}} \times 100\%$$

Note 7: Definition of cross talk.

Cross talk ratio(%)=|pattern A Brightness-pattern B Brightness|/pattern A Brightness*100

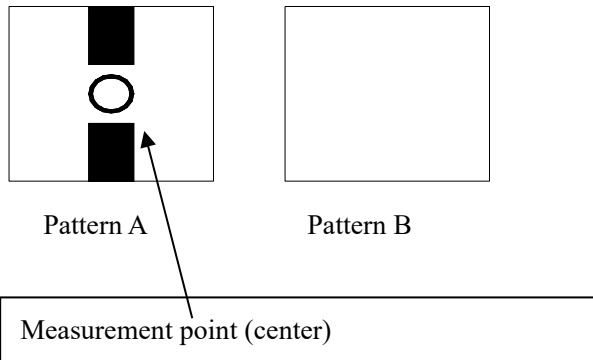

Electric volume value=3F+/-3Hex

6. TTL Characteristics & Reset Timing

6.1 TTL Characteristics

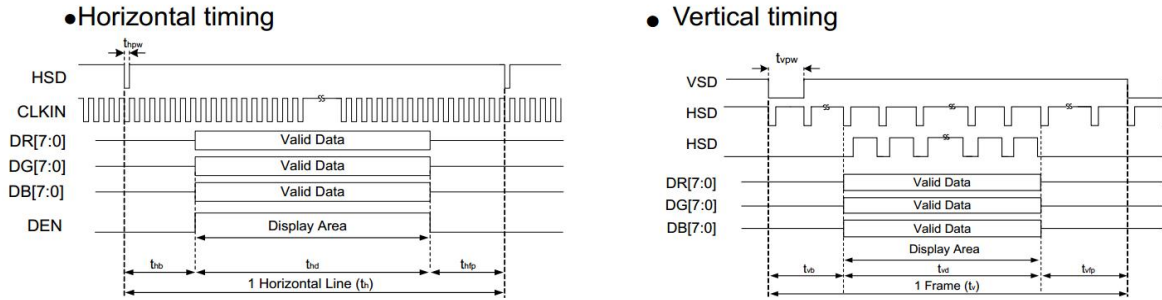

Figure 8.1: 24-bit parallel RGB mode horizontal/vertical input timing

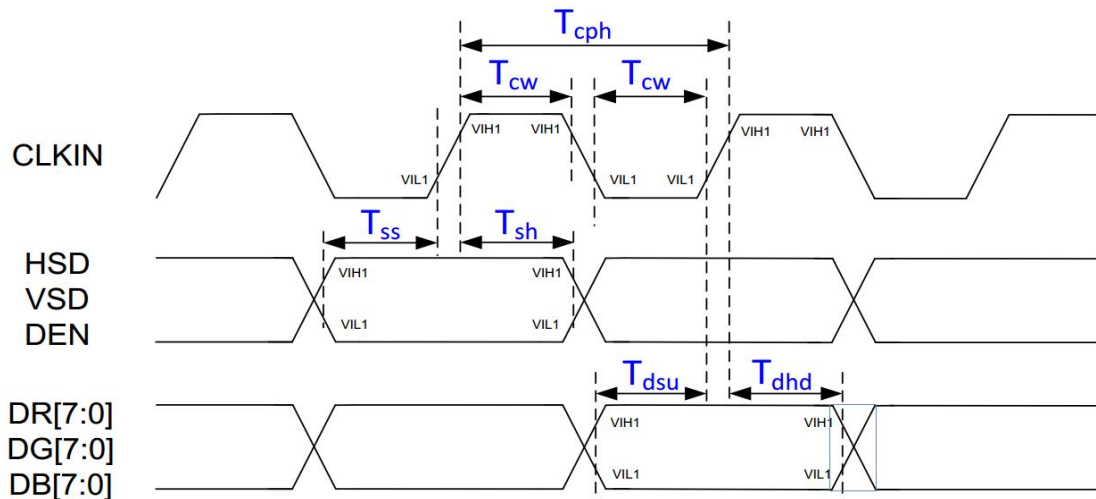

Figure 8.2: Input signal timing

Input data /sync parameters

Parameter	Symbol	Spec.			Unit
		Min.	Typ.	Max.	
CLKIN period	T_{cph}	14	-	-	ns
CLKIN duty ratio	T_{cw}	40	50	60	%
Data setup time	T_{dsu}	5	-	-	ns
Data hold time	T_{dhd}	5	-	-	ns
VSD setup time	T_{ss}	5	-	-	ns
VSD hold time	T_{sh}	5	-	-	ns
HSD setup time	T_{ss}	5	-	-	ns
HSD hold time	T_{sh}	5	-	-	ns
DEN setup time	T_{ss}	5	-	-	ns
DEN hold time	T_{sh}	5	-	-	ns

Table 8.3: TTL mode AC electrical characteristics

6.2 RESET Timing

When RESX of the reset pin equals to Low, it will be in the condition of reset.
 When it is in the condition of reset, it will make the device recover the initial set.

However, in order to avoid the reset noise cause reset, there is a mechanism to judge about whether the reset is needed or not.

The closed interval of Low can be shown as the following.

(Test condition: VDD=1.71V to 1.89V / 2.8V to 3.6V , VSS=0V, TA=-30 ~+85)

Parameter	Symbol	Conditions	Spec.			Unit
			Min.	Typ.	Max	
Reset low pulse width	Trst		6	-	-	μs

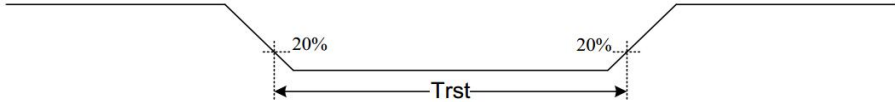

7. Power on/off Sequence

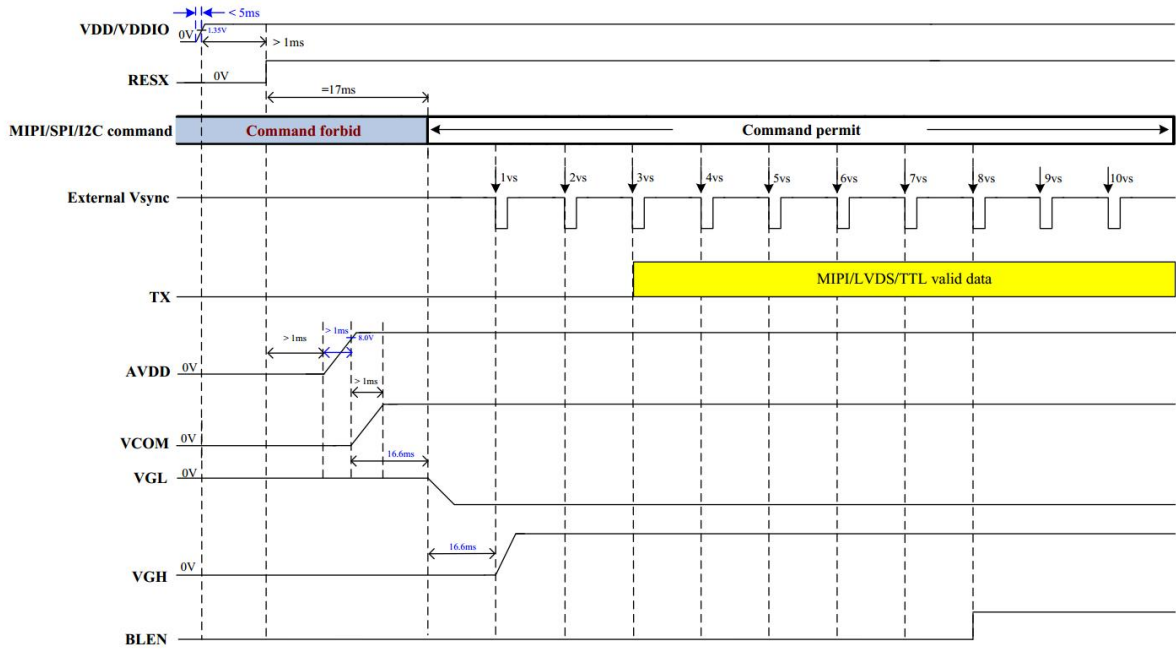

Figure 9.1: Power On timing chart

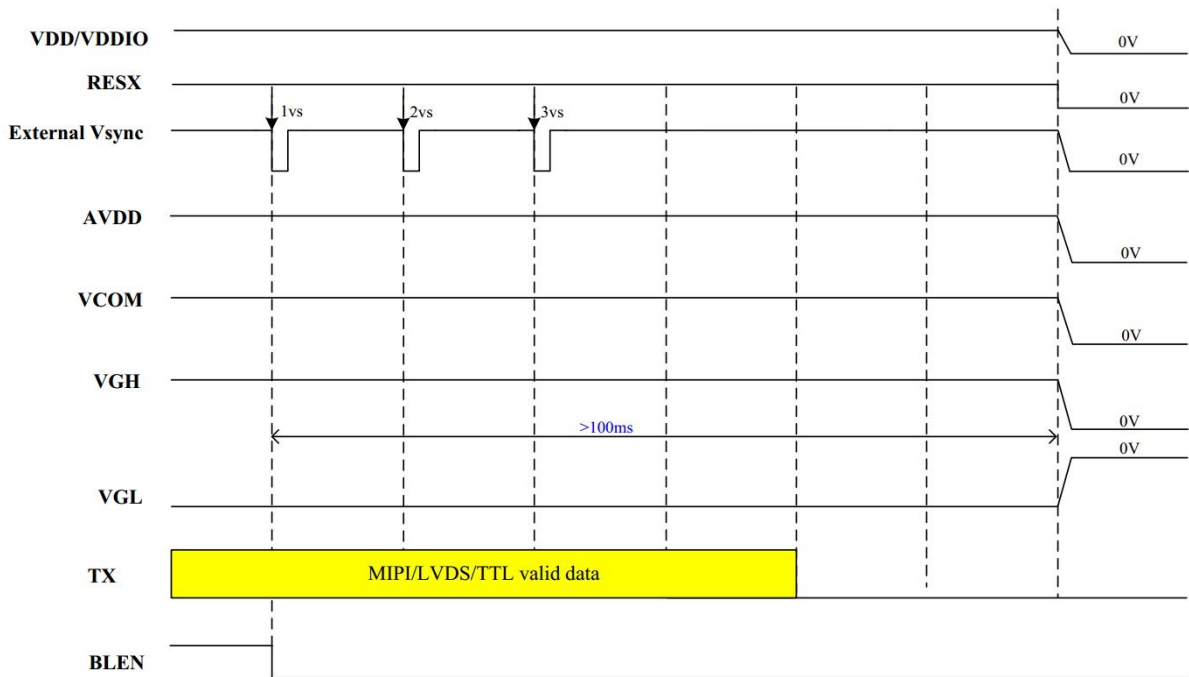

Figure 9.2: Power Off timing chart

Note: VDD, VDDIO are connected together internally, named DVDD.

8. Reliability Test Items and Criteria

No	Test Item	Test condition	Criterion
1	High Temperature Storage	80°C 96H Restore 2H at 25°C Power off	1. After testing, cosmetic and electrical defects should not happen. 2. Total current consumption should not be more than twice of initial value.
2	Low Temperature Storage	-30°C 96H Restore 2H at 25°C Power off	
3	High Temperature Operation	70°C 96H Restore 2H at 25°C Power on	
4	Low Temperature Operation	-20°C 96H Restore 2H at 25°C Power on	
5	High Temperature/Humidity Operation	50°C 90%RH 96H Power on	
6	Temperature Cycle	-20°C ←-----→ 70°C 30min 5min 30min after 5 cycle, Restore 2H at 25°C Power off	
7	Vibration Test	10Hz~150Hz, 100m/s ² , 120min	Not allowed cosmetic and electrical defects.
8	Shock Test	Half- sine wave, 300m/s ² , 11ms	
9	ESD Test	Air discharge: ±8KV, (150PF, 330Ω) Contact discharge: ±4KV (150PF, 330Ω)	

Note: Operation: Supply 3.3V for logic system.

The inspection terms after reliability test, as below

ITEM	Inspection
Contrast	CR>50%
IDD	IDD<200%
Brightness	Brightness>60%
Color Tone	Color Tone+/-0,05

9.检验标准

9.1 AQL 定义

9.1.1 抽样计划

外观、功能依照 MIL-STD - 105E 标准, II 检验水平执行抽检;

9.1.2 接收质量限 (AQL)

重要缺陷: C=0 主缺陷: 0.4 次缺陷: 1.0

客户有特殊要求则依客户要求定之

9.2 缺陷定义:

重缺陷 (CR): 影响显示的功能, 例如短路、断路、漏液等;

主缺陷 (MA): 影响显示的功能, 例如缺划、大电流、视角错、显示不清等; 严重外观缺陷, 产品尺寸不符等;

次缺陷 (MI): 不影响产品功能, 但对产品外观有影响, 例如: 反黑/反白点、偏光片缺陷、污点;

9.3 屏幕检验区定义:

9.3.1. 分区如图

A 区: 在整机中画面显示区中间之 3/5 可以被看到的区域。

B 区: A 区以外的显示区。

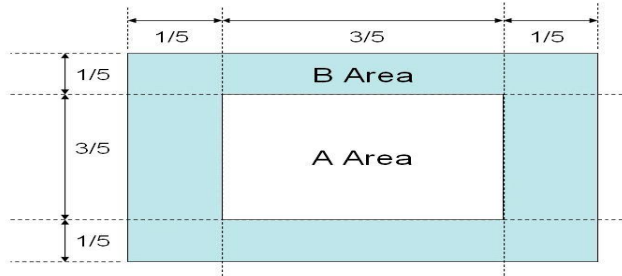

10. 检验要求

10.1 检验条件:

- 1) .温度、湿度:
温度, 15°C~30°C; 湿度, 50%±25%。
- 2) .距离
人眼与被测物表面的距离为 30cm±5cm。
- 3) .位置
产品检视面与法线上下左右各转动 45 度。

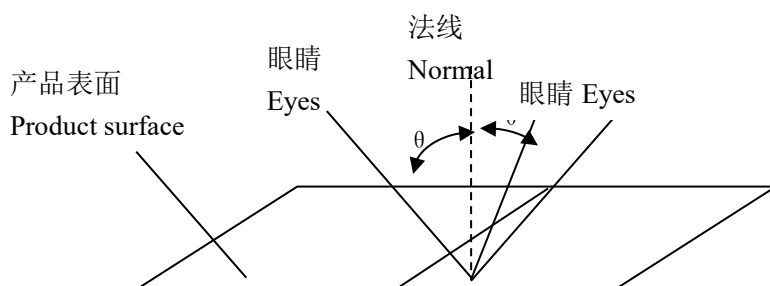

- 4) .环境照度:
外观检验: 100W 冷白荧光灯 (光源在检测物正上方), 光照强度为 1000±200LUX ;
电性测试: 环境照度为 100±50LUX
- 5) .检视时间
外观表面标准检视时间为 10±5S。在 15S 内缺陷仍不可见视为合格品。
- 6) .检视人员要求
检视人员视力需在 1.0 以上 (含矫正视力)。

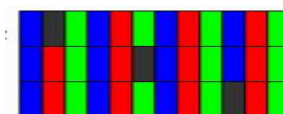
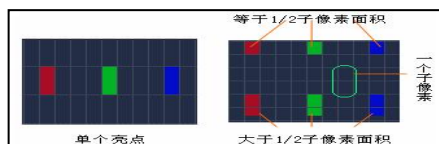

- 7) .其它要求
 - a. 检验员必须带手指套及防静电手环并测试合格。
 - b. 测试检验平台必须要有防静电措施并测试合格。

图 (3) Figure

图 (4) Figure

11.2. 检验标准 (以下设计尺寸标准的单位非特殊说明均为 mm)

11.2.1. 点缺陷检验标准

11.2.1.1 点缺陷定义:

像素亮点: 由于 TFT 失效造成一个子像素一直发光, 成为像素亮点, 如图 (3)

像素暗点: 由于 TFT 失效造成一个子像素 一直不发光, 成为像素暗点, 如图 (4)

杂质点: 除像素点以外的其它模糊点, 污点, 色点, 其形状定义: $X/Y < 2.5$, 如图 (5)

点直径(d)计算: $d=(X+Y)/2$
 点间距 DS 的计算: 如图 (6)



图 (5) Figure



图 (6) Figure

11.1.1.2 点缺陷检验标准 (点/线状判定 : 点/线状不良大小依据菲林卡搭配目镜比对判定是否合格)

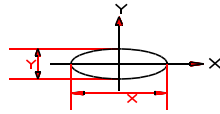
项目 Project	A 规		判定方法	缺陷区分	
	规格	数量			
杂质点		$d \leq 0.15$	不计	次缺	
	A 区	$0.15 < d \leq 0.25$	1		
	B 区	$0.15 < d \leq 0.25$	1	次缺	
		$d > 0.25$	0		
像素点 Pixel points	A 区	亮点	0	目视、菲林卡、 目镜	
		暗点	1		
	B 区	亮点	0		次缺
		暗点	1		
满天星	$d \leq 0.1\text{mm}$, 直径 30mm 范围内, $n \leq 10$			次缺	
两连点	N=0				
三连点	不允许				
备注	点缺陷总数 $N \leq 3$ 个, 两缺陷之间距离 $DS > 20\text{mm}$.			次缺	

11.2.2 线缺陷检验标准 (点/线状判定 : 点/线状不良大小依据菲林卡搭配目镜比对判定是否合格)

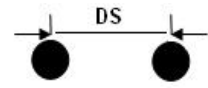
11.2.2.1. 线缺陷定义,如图(7)Line defect definitions, as shown

(7) $b/a \geq 2.5$



图 (7)

备注:屏内线状杂质, 包括屏幕盒内毛线、纤维、贴片杂质, 偏光片表面划伤, 玻璃划伤等.

11.2.2.2.线缺陷检验标准

分区	A 规		判定方法	缺陷区分
	规格	数量		
	$W \leq 0.03$	不计		
A 区	$L \leq 2.0$ $0.03 < W \leq 0.05$	1	目视、菲林卡、目镜	次缺
B 区	$L \leq 2.0$ $0.03 < W \leq 0.05$	1		
	$L > 2.0$ 或 $W > 0.05$	0		

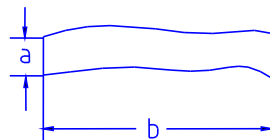

11.3.POL 不良检验标准

不良项目	现象描述	判定标准	判定方法	缺陷区分
边缘气泡	/	上片:气泡距离显示区边缘黑色边框二分之一,且气泡长度<5mm,判 OK; 下片:气泡不进入显示区,判 OK; 注:要求气泡与 POL 边缘不相通,以不能进入空气为原则	目视、菲林卡	次缺
面内气泡	异物气泡或空气泡	$d \leq 0.2\text{mm}$, $N \leq 2$; $d > 0.2\text{mm}$, 不允许	目视、菲林卡	
贴附偏移	偏光片相对于玻璃的位置偏移	片边缘与显示区边缘距离>0.3mm,且不超出玻璃边缘判 OK, 测试不可见漏边;	目视、卡尺	
片损伤	刮伤, 压伤, 凹痕	按照点、线缺陷判断	目视	
电测发白	偏光片裁切角度异常	参照限样	目视	
保护膜不良	破损, 翻卷, 明显脏污	不允许	目视	
易撕贴不良	1.贴附位置与工程图不符; 2.不易揭起保护膜	1.参照图纸; 2.以揭起一个角效果判定。	目视	
片白边	偏光片边缘白边	上片要求: $W < 0.2\text{mm}$ 且不可有锯齿或毛边现象 下片要求: 不进显示区即可	目视	
偏光片脏污	不可清除的脏污	不进入可视区 OK。	目视	
材料用错	颜色不符, 砂型不符		目视 Visual	重缺

11.4 功能类不良

不良项目	现象描述	判定标准	判定方法	缺陷区分
无显	不能显示画面	不允许	目视、测试架	重缺
显异	与正常显示画面内容或颜色有明显差异	不允许	目视、测试架	重缺
缺画	以像素为单位的水平,垂直或交叉不显示	不允许	目视、测试架	重缺
屏闪	全显示画面出现规律性的闪动	依限度样板	目视、测试架	主缺
边缘漏光	LCD 显示区边缘局部偏亮	依限度样板	目视、测试架	次缺
显示不均	局部位置对比度出现显示深/浅不一致的现象	不允许, 特殊情况下参照限样	目视、测试架	次缺
显淡/显浓	画面显示颜色较正常过深或过浅	按照规格书电压偏差要求控制或按照限度样板	目视、测试架	次缺
水波纹	灰阶画面或特定图形画面可见的局部波纹状抖动.	依限度样板	目视、测试架	次缺
LCDMura	黑色画面发白、发蓝、彩斑等 .	使用 ND 5%进行判定	目视、ND 5%滤光片	次缺
残影	切换至下一个画面时有上一个画面的影子		根据各 LCD 供应商 IIS 进行判定	次缺
画面不动	驱动时画面无法切换	不允许	目视、测试架	重缺
串扰	视窗画面出现的水平或垂直颜色交叉混色现象	不允许	目视、测试架	次缺

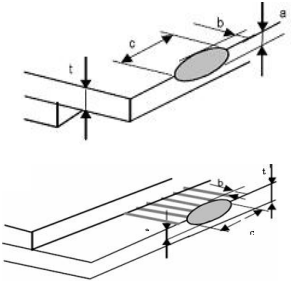
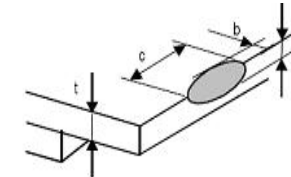
11.5 外观类不良

不良项目	现象描述	A+判定标准	A判定标准	判定方法	缺陷区分
崩边/崩角 (单层区)		$a \leq t$, $b < 0.5\text{mm}$, $c < 2\text{mm}$, 且不伤及线路 判 OK.	Dummy 区域: $a \leq t$, $b < 2\text{mm}$, $c < 5\text{mm}$; 线路区: $a \leq t$, $b < 0.5\text{mm}$, $c < 2\text{mm}$, 且不伤及线路判 OK.	目视、菲林卡	次缺
崩边/崩角 (双层区)		$a \leq t$, $b < 0.5\text{mm}$, $c < 2\text{mm}$, 不伤及线路判 OK;	$a \leq t$, $b < 0.5\text{mm}$, $c < 5\text{mm}$, 不伤及线路判 OK;	目视、菲林卡	次缺
延伸性裂痕		不允许		目视	重缺
LCD 破裂	/	不允许		目视	主缺
凸边	/	影响外形尺寸及组装,不允许		目视	主缺
玻璃划伤	LCD 表面划伤	无感刮伤长度 $L \leq 3.0\text{mm}$;有感刮伤,不允许		目视	次缺
切割不良	切割偏移, 锯齿, 毛边等	不允许		目视 Visual	主缺
LCD 漏液	因框胶开裂, 密封不严或封口未封住, 导致液晶漏出。	不允许		目视	重缺
液晶气泡	组立制程导致的 cell 内空气泡或真空泡	不允许		目视	主缺
IC 破	/	不允许		目视	重缺
ACF 偏位	/	ACF 需超出 IC 边缘, 否则判 NG		目视	次缺
涂胶不良	胶表面有凸起, 针孔或气泡	不允许		目视	次缺
少胶	保护胶未完全覆盖 TFT 测线路	不允许		目视	次缺
多胶	保护胶过多流到 FPC 或上玻璃	不允许		目视	次缺

11.6.FPC 类不良 FPC type Bad

不良项目	现象描述	判定标准	判定方法	缺陷区分
尺寸超标	外观尺寸超出图纸要求	不允许	目视、游标卡尺	主缺
FPC 划伤	FPC 表面划伤	露铜不允许	目视	次缺
FPC 折痕	FPC 上出现的死折、引线断裂	死折不允许，功能缺陷不允许	目视	主缺
FPC 脏污	FPC 表面脏污	金手指位置不允许，其他位置脏污可擦除可接受判 OK	目视	次缺
金手指氧化	FPC 金手指氧化	不允许	目视	主缺
金手指破损	金手指破损、折断	不允许	目视	主缺
补强板不良	补强板开裂，脱落	不允许	目视	主缺
FPC 少器件	FPC 上少器件	不允许	目视	主缺
FPC 分层	FPC 分层、起泡	不允许	目视	主缺
FPC 损坏	FPC 损坏	不允许	目视	主缺
焊接不良	虚焊、假焊、少焊锡、连锡，FPC 上连接器焊接后 PIN 脚上沾锡，连锡。	不允许	目视、烙铁台	主缺
FPC 左右 PIN 角均匀性	FPC 第一根 PIN 角外露加强板边沿与最后一根 PIN 角外露加强板边沿需均匀符合设计图纸要求，否则不合格	根据图纸要求	目视、游标卡尺、图纸	次缺
器件偏位	FPC 上器件偏位	横向小于焊盘宽度的 20%，纵向小于器件焊端纵向宽度的 30%。	目视	次缺
喷码不良	无喷码、喷码模糊、与图纸/样品不符	A+规:无喷码、喷码模糊、与图纸/样品不符判 NG;	目视	次缺
丝印不良	无丝印、丝印模糊，与图纸/样品不符	A+规:无丝印、丝印模糊，与图纸/样品不符判 NG	目视	次缺

11.7 B/L 类不良

不良项目	现象描述	判定标准	判定方法	缺陷区分
铁框生锈	铁框氧化生锈	不允许	目视	次缺
黑屏	通电状态, LCD 被驱动但无背光	不允许	目视	重缺
灯不稳定	B/L 点亮灯不稳定时亮时暗	不允许	目视	重缺
焊盘脱落	B/L 排线焊盘完全脱落或脱落面积大于焊盘 1/3	不允许	目视	主缺
铁框变形	铁框变形	不允许	目视	次缺
铁框划伤	铁框表面划伤	不允许	目视	次缺
背光不均	背光显示出现亮斑、暗场、灯影等背光不均现象	不允许, 特殊情况下见限度样板	目视、点灯治具	主缺
色坐标偏	全白画面下, 不同的屏幕之间颜色存在差异	按规格书要求, 同时参考限度样板	BM-7 判定	次缺
灯颜色不均	同一屏幕在全白画面下, 屏幕局部出现颜色不均	不允许, 特殊情况下参考限度样板	目视	主缺
背光脏污	背光显示像素亮点、杂质点、色点等.	按照点、线缺陷控制	目视	次缺
尺寸不符	超出图纸规格	不允许	游标卡尺	主缺
背光变形	背光翘曲、变形	不允许	目视	次缺
亮度偏差	背光亮度偏暗/亮	按照规格要求, 参考限度样板	BM-7 测试	主缺
铁框卡扣不良	1. 下铁凸包未卡入上铁卡口内导致松脱; 2. 上下铁间隙过大	不允许	目视	次缺
铁框花纹不一致	上下铁框花纹大小不一致;	不允许	目视	次缺
喷码不良	无喷码、喷码模糊、与图纸/样品不符	A+规: 无喷码、喷码模糊、与图纸/样品不符判 NG;	目视	次缺
背光灯眼、漏光	亮眼、漏光(边框漏光): 进入 LCD 的 A、B 区;	不允许	目视	次缺
丝印不良	无丝印、丝印模糊, 与图纸/样品不符	A+规: 无丝印、丝印模糊, 与图纸/样品不符判 NG	目视	次缺

11.8 TP 类不良

不良项目	现象描述	判定标准			判定方法	缺陷区分
TP 点异物黑 白点	1、TP 表面异物、刺伤、组装异物、杂质等均属之 2、如若允许两个不良，两点之间的距离需 $\geq 10\text{mm}$ 3、不良在 VA 区以外不计	直径 ϕ	允收数		目视、菲林卡	次缺
		$\phi \leq 0.15$	不计 Negligible			
		$0.15 < \phi \leq 0.20$	2			
		$\phi > 0.20$	0			
TP 刮伤	1、TP 表面刮伤、组装异物、线性异物、毛线等 2、如若允许两个不良，两线之间的距离需 $\geq 10\text{mm}$ 3、不良在 VA 区以外不计	宽度 T(mm)	长度 L (mm)	允收数	目视、菲林卡	次缺
		$T \leq 0.03$	不计	不计		
		$0.03 < T \leq 0.05$	$L \leq 5.0$	2		
		$T > 0.05$	不计	NG		
牛顿环		有规则牛顿环、大于触摸屏面积的 1/6 且点灯影响文字及直线失真，不可有			目视	次缺
无动作 No	TP 测试时点不动、无动作	不允许			目视、测试架	主缺
断线	TP 测试时画线有断线情况	不允许			目视、测试架	主缺
飘移	TP 画线位置飘移 $\leq 1.5\%$	允许			目视、测试架	主缺
TP 贴歪	TP 四周不可超出铁框边缘	以铁框框面直视不可超出铁框边缘，直视可见 TP 边，不允许			目视	主缺

11.9 包装类不良

不良项目	现象描述	判定标准	判定方法	缺陷区分
物料错误	错料，混料	不允许	目视	重缺
产品的摆放	与该型号的对应的指导书不符	不允许	目视	主缺
喷码有误	与成品喷码要求不符	不允许	目视	主缺
数量不符	与包装 BOM 不符（多数/少数）或与外包装标注的数量不一致	不允许	目视	主缺
包装箱	包装箱变质，破损，打包不牢固（未按客户要求）	不允许	目视	主缺

12. Precautions for Use of LCD Modules

12.1 Handling Precautions

12.1.1 The display panel is made of glass. Do not subject it to a mechanical shock by dropping it from a high place, etc.

12.1.2 If the display panel is damaged and the liquid crystal substance inside it leaks out, be sure not to get any in your mouth, if the substance comes into contact with your skin or clothes, promptly wash it off using soap and water.

12.1.3 Do not apply excessive force to the display surface or the adjoining areas since this may cause the color tone to vary.

12.1.4 The polarizer covering the display surface of the LCD module is soft and easily scratched. Handle this polarizer carefully.

12.1.5 If the display surface is contaminated, breathe on the surface and gently wipe it with a soft dry cloth. If still not completely clear, moisten cloth with one of the following solvents:

- Isopropyl alcohol
- Ethyl alcohol

Solvents other than those mentioned above may damage the polarizer.

Especially, do not use the following:

-
- Water
 - Ketone
 - Aromatic solvents

12.1.6 Do not attempt to disassemble the LCD Module.

12.1.7 If the logic circuit power is off, do not apply the input signals.

12.1.8 To prevent destruction of the elements by static electricity, be careful to maintain an optimum work environment.

- a. Be sure to ground the body when handling the LCD Modules.
- b. Tools required for assembly, such as soldering irons, must be properly ground.
- c. To reduce the amount of static electricity generated, do not conduct assembly and other work under dry conditions.
- d. The LCD Module is coated with a film to protect the display surface. Be care when peeling off this protective film since static electricity may be generated.

12.2 Storage precautions

12.2.1 When storing the LCD modules, avoid exposure to direct sunlight or to the light of fluorescent lamps.

12.2.2 The LCD modules should be stored under the storage temperature range.

If the LCD modules will be stored for a long time, the recommend condition is:

Temperature : 0°C ~ 40°C

Relatively humidity: ≤80%

12.2.3 The LCD modules should be stored in the room without acid, alkali and harmful gas.

12.3 The LCD modules should be no falling and violent shocking during transportation, and also should avoid excessive press, water, damp and sunshine.