

Product Specification

Customer	Standard Model
Model Name	Z035Q01-T
Description	TFT LCD Module 3.5" QVGA 320(RGB)x240 Dots
Date	2017/07/21
Version	V1.0

Customer Approval	
Date	
<p>The above signature represents that the product specifications, testing regulation, and warranty in the specifications are accepted</p>	

Engineering			
Check	Date	Prepared	Date

Table of Contents



1 Record of Revision	3
2 General Specifications	4
3 Pin Definition	5
4 Absolute Maximum Ratings	6
5 Electrical Characteristics	6
6 Interface Timing	8
7 Optical Characteristics	12
8 Environmental / Reliability Tests	15
9 Mechanical Drawing	16
10 Packing	17
11. Precautions For Use of LCD modules	18



2. General Specifications

	Feature	Spec
Characteristics	Size	3.5inch
	Resolution	320(horizontal)*240(Vertical)
	Glass Maker	Tianma
	Interface	8/24bit-RGB CCIR601/656
	Connect type	Connector
	Display Colors	16.7M
	Technology type	a-Si
	Pixel pitch (mm)	0.219 x 0.219
	Pixel Configuration	R.G.B. Stripe
	Display Mode	Normally White
	Driver IC	NV3035
	Luminance	350nits
	Viewing Direction	12 O'clock
	Gray Scale Inversion Direction	6 O'clock
Mechanical	LCM (W x H x D) (mm)	76.90*64.0*4.25
	Active Area(mm)	70.08 x 52.56
	With /Without TSP	With
	Weight (g)	28g
	LED Numbers	6LEDs (6S)

Note 1: Viewing direction is following the data which measured by optics equipment.

Note 2: Requirements on Environmental Protection: RoHS

Note 3: LCM weight tolerance: +/- 5%



3. Pin Definition

No.	Symbol	Description
1,2	VBL-	Backlight LED Cathode
3,4	VBL+	Backlight LED Anode.
5~7	NC	NC
8	RESET	Reset Signal pin ("Low" is enable)
9	SPENB	Chip select
10	SPCK	Serial Clock.
11	SPDA	Serial Data
12-19	B0~B7	Data bus
20-27	G0~G7	Data bus
28-35	R0~R7	Data bus
36	HSYNC	Line Synchronous Signal
37	VSYNC	Frame Synchronous Signal
38	DOTCLK	Dot-clock signal and oscillator source
39-40	NC	NC
41-42	VCC	Power supply for logic operation
43-47	NC	NC
48	XR	Touch panel right side
49	YD	Touch panel bottom side
50	XL	Touch panel left side
51	YU	Touch panel up side
52	DEN	Display enable signal
53-54	GND	System Ground

4. Absolute Maximum Ratings

Item	Symbol	MIN	MAX	Unit	Remark
Supply Voltage	V_{DD}	-0.5	5.0	V	
Operating Temperature	T_{OPR}	-20	70	°C	
Storage Temperature	T_{STG}	-30	80	°C	

5. Electrical Characteristics

5.1 Driving TFT LCD Panel

$T_a = 25\text{ }^\circ\text{C}$

Item	Symbol	MIN	TYP	MAX	Unit	Remark
Digital Supply Voltage	V_{DD}	3.0	3.3	3.6	V	
Input Signal Voltage	Low Level	V_{IL}	GND	-	$0.1 \times V_{DD}$	V
	High Level	V_{IH}	$0.8 \times V_{DD}$	-	VDD	V
TFT Common Electrode	V_{COMH}	2.5	-	4.5	V	
TFT Gate ON Voltage	V_{GH}	-	15	-	V	
TFT Gate Off Voltage	V_{GL}	-	-10	-	V	

5.2 Driving Backlight

Item	Symbol	MIN	TYP	MAX	Unit	Remark
Forward Current	I_F	-	20	25	mA	
Forward Voltage	V_F	-	19.2	19.8	V	
Backlight Power consumption	W_{BL}	-	0.384	0.495	W	
LED Lifetime		25000	-	-	Hrs	

Note 1: Each LED: $I_F = 20\text{ mA}$, $V_F = 3.2\text{ V}$.

Note 2: Optical performance should be evaluated at $T_a = 25\text{ }^\circ\text{C}$ only.

Note 3: If LED is driven by high current, high ambient temperature & humidity condition. The life Time of LED will be reduced. Operating life means brightness goes down to 50% initial brightness. Typical operating life time is estimated data.

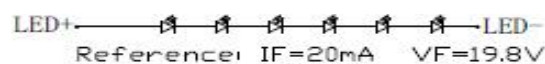
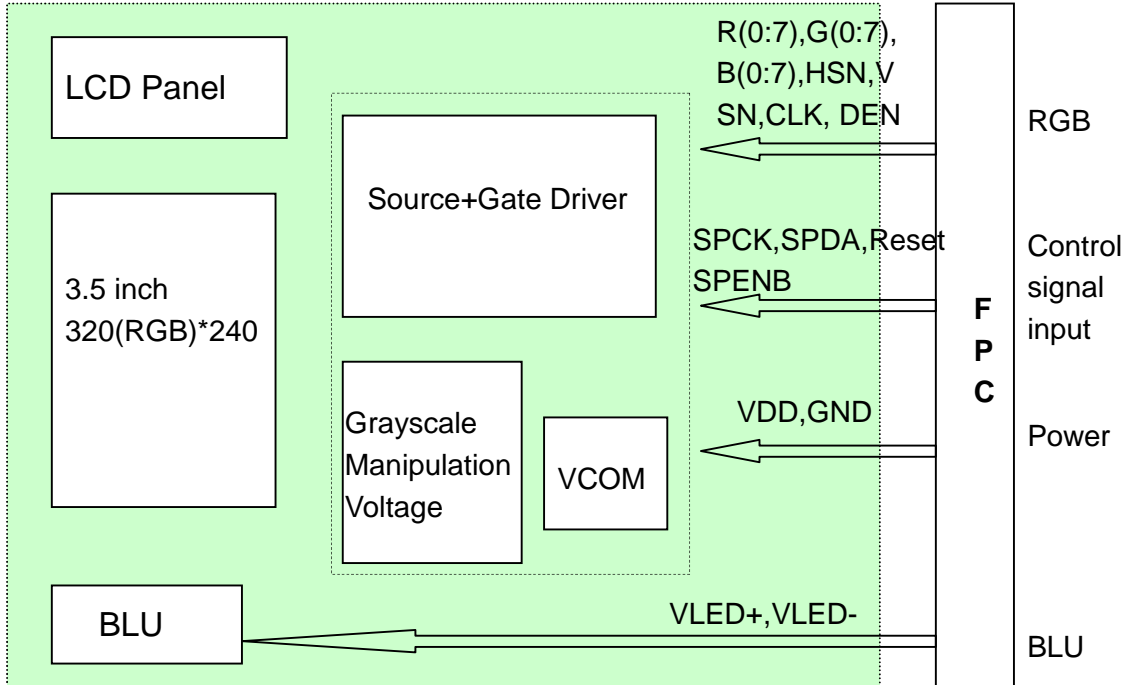

Figure: LED connection of backlight



5.3 Block Diagram





6. Interface Timing

6.1 AC Electrical Characteristics

Test Condition: (VDD=VDDP=3.3V, VDDA=5.0V, GND=GND A=GNDP=0V, TA= 25°C)

Parameter	Symbol	Min.	Typ.	Max.	Unit	Conditions
System Operation Timing						
VDD power source slew time	T _{POB}			1000	us	From 0V to 90% VDD
RSTB active pulse width	T _{RSTB}	40			us	VDD = 3.3V
Input Output Timing						
CLKIN clock time	T _{clk}	33.3/125	-	-	ns	Please refer to timing table(p.32)
HSD to CLKIN	T _{hc}	-	-	1	CLKIN	
HSD width	T _{hwh}	1	-	-	CLKIN	
VSD width	T _{vwh}	1	-	-	Th	
HSD period time	T _h	60	63.56	67	us	
VSD setup time	T _{vst}	8	-	-	ns	
VSD hold time	T _{vhd}	10	-	-	ns	
HSD setup time	T _{hst}	8	-	-	ns	
HSD hold time	T _{hhd}	10	-	-	ns	
Data set-up time	T _{dsu}	8	-	-	ns	DIN[23:0] to CLKIN
Data hold time	T _{dhd}	10	-	-	ns	DIN[23:0] to CLKIN
DEN setup time	T _{esd}	12	-	-	ns	DEN to CLKIN
Time that VSD to 1 st line data input	T _{vs}	2	13	127	Th	@CCIR601 / 8bit RGB HV mode Control by HDLY[6:0] setting T _{vs} = HDLY[6:0]
Time that CCIR_V to 1 st line data input	T _{vs}	12	20	28	Th	@CCIR656 NTSC mode Control by HDLY[6:0] setting T _{vs} = HDLY[6:0]
Time that CCIR_V to 1 st line data input	T _{vs} 17 25 33 Th					@CCIR656 PAL mode Control by HDLY[6:0] setting T _{vs} = HDLY[6:0]
Time that VSD to 1 st line data input	T _{vs}	2	13	127	Th	@24bit RGB HV mode Control by HDLY[6:0] setting T _{vs} = HDLY[6:0]
Source output stable time 1	T _{st}	-	25	30	us	96% final, CL=30pF, RL=2K
Gate output stable time	T _{gst}	-	500	1000	ns	96% final, CL=40pF
VCOMOUT output stable time	T _{cst}	-	4	8	us	96% final, CL=33nF, RL=100ohm
3-wire serial communication AC timing						
Serial clock	T _{spck}	320	-	-	ns	
SPCK pulse duty		40	50	60	%	T _{ckh} / T _{spck}
Serial data setup time	T _{isu}	120	-	-	ns	
Serial data hold time	T _{ihd}	120	-	-	ns	
Serial clock high/low	T _{ckh/l}	120	-	-	ns	
Chip select distinguish	T _{cd}	1	-	-	us	
SPENB to VSD	T _{cv}	1	-	-	us	
SPENB input setup time	T _{eck}	150	-	-	ns	
SPENB input hold time	T _{cke}	150	-	-	ns	



6.2 DC Electrical Characteristics

(For the digital circuit: Test Condition: VDD=VDDP=3.3V , VDDA=5.0V, GND=GND A=GNDP= 0V, TA=25°C)

Parameter	Symbol	Min.	Typ.	Max.	Unit	Conditions
Digital Block Circuit						
Digital Supply Voltage	VDD	3.0	3.3	3.6	V	Digital power
Low Level Input Voltage	Vil	GND	-	0.2xVDD	V	Digital input pins TA=85°C
High Level Input Voltage	Vih	0.8xVDD	-	VDD	V	Digital input pins TA=85°C
Low Level Input Voltage	Vil	GND	-	0.2xVDD	V	Digital input pins TA=25°C
High Level Input Voltage	Vih	0.8xVDD	-	VDD	V	Digital input pins TA=25°C
Low Level Input Voltage	Vil	GND	-	0.1xVDD	V	Digital input pins TA= -20°C
High Level Input Voltage	Vih	0.9xVDD	-	VDD	V	Digital input pins TA= -20°C
Input Leakage Current	Ii	-	-	±1	µA	Digital input pins
Pull-high/low Impedance	Rin	-	200K	-	ohm	Digital control input pins
High Level Output Voltage	Voh	VDD-0.4	-	VDD	V	Digital output pins; Ioh = 400 uA
Low Level Output Voltage	Vol	GND	-	GND+0.4	V	Digital output pins; Iol = -400 uA
Digital Stand-by Current	Iddst	-	(50)	(100)	uA	No load, CLKIN/VSD/HSD stopped
Digital Operating Current	Idd1	-	2	-	mA	CLKIN = 27 MHz (CCIR601 mode)
Power Circuit						
Charge Pump Supply Voltage	VDDP	3.0	3.3	3.6	V	For VGH/VGL power and Source Driver power, must in this range
VCOMAC output level	VCOMAC	4.6	-	6.1	V	By VCSSL[2:0] setting VCOMAC = V _(vcssl[2:0]) ± 100mV
VCOMDC output level	VCOMDC	1.0	-	2.26	V	By VCDCSL[5:0] setting VCOMDC = V _(vcdcsl[5:0]) ± 50mV
Positive power supply	VGH	14.5	15	15.5	V	Gate driver load + procard load
Negative power supply	VGL	-9	-10	-11	V	Gate driver load + procard load
Base drive current	IDRV	-	-	10	mA	VDDP=3.3V, DRV=0.7 V
DRV output voltage	VDRV	GND +0.1	-	VDD -0.1	V	
Feed back voltage	VFB	0.55	0.6	0.65	V	DC/DC operating, VBL current=20 mA

6.3 24 Bit RGB Mode

Parameter	Symbol	Min.	Typ.	Max.	Unit	Conditions
CLKIN frequency	Fclk	6.1	6.4	8.0	MHz	VDD = 3.0 ~3.6V
CLKIN cycle time	Tclk	125	156	164	ns	
CLKIN pulse duty	Towh	40	50	60	%	Tclk
Time that HSD to 1st data input(NTSC)	Ths	40	70	255	CLKIN	DDLY =70, Offset = 0 (fixed)

6.4 Input Data Timing (24 bit RGB mode for 960 x 240 @ SEL[3:0] = 1100b)

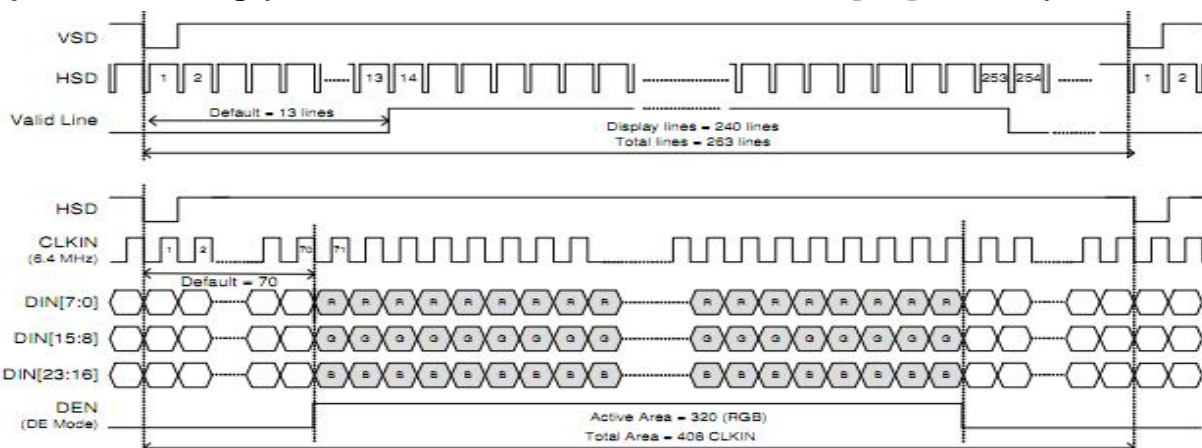

6.5 Vertical Timing Diagram (HV Mode)

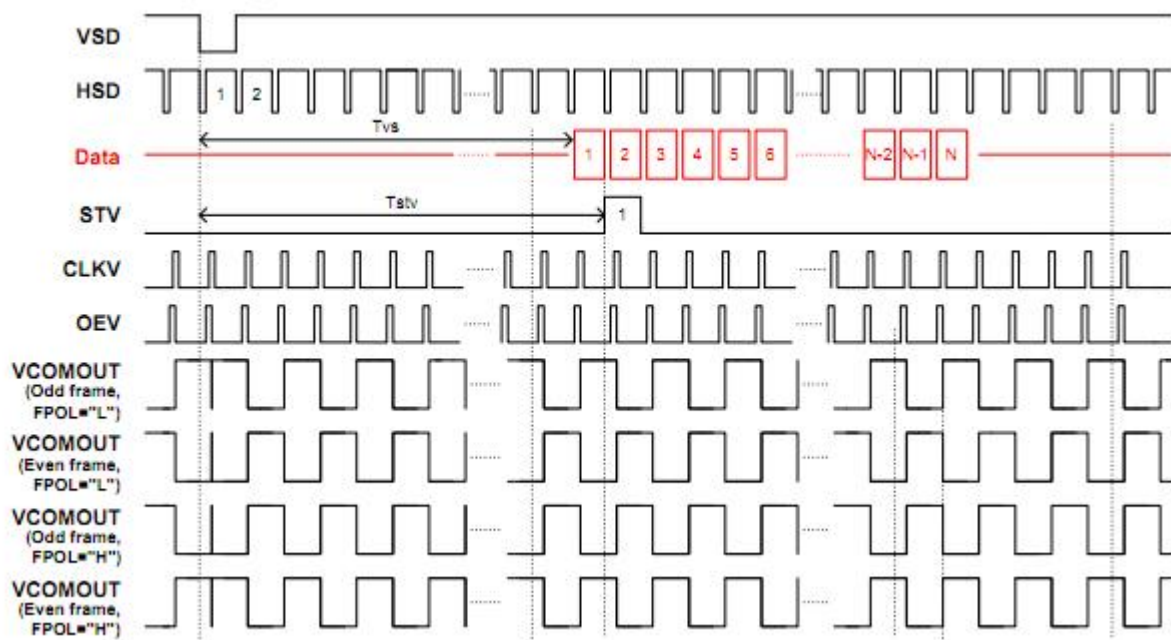

6.6 Vertical Timing Diagram (DE Mode)

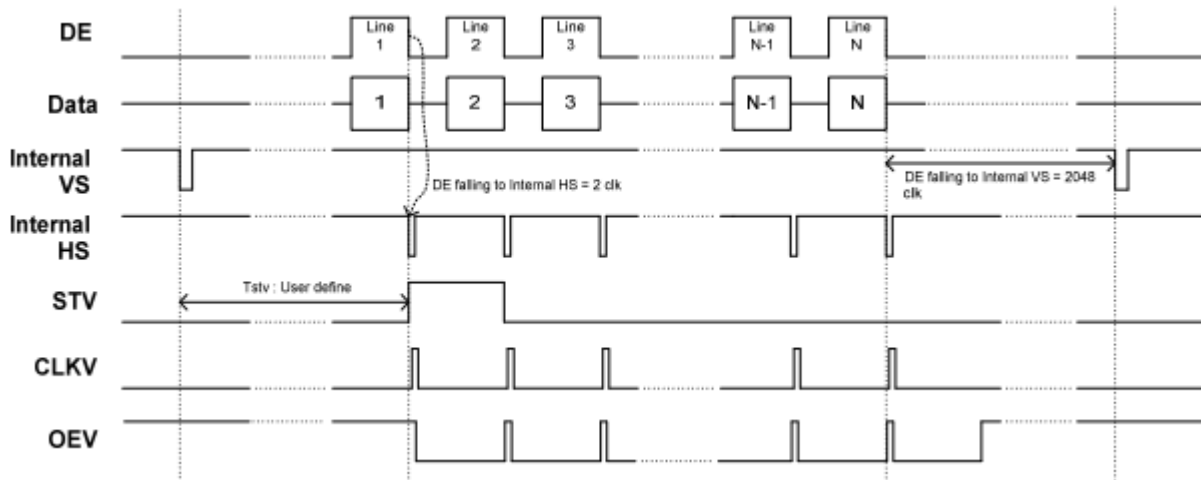



6.7 3-Wire Serial Port Interface

3-Wire Command Format

NV3035 uses the 3-wire serial port as communication interface for all the function and parameter setting.

3-Wire communication can be bi-directional controlled by the "R/W" bit in address field. NV3035 3-Wire engine act as a "slave mode" for all the time, and will not issue any command to the 3-Wire bus itself.

Under read mode, 3-Wire engine will return the data during "Data phase". The returned data should be latched at the rising edge of SPCK by external controller. Data in the "Hi-Z phase" will be ignored by 3-Wire engine during write operation, and should be ignored during read operation also. During read operation, external controller should float SPDA pin under "Hi-Z phase" and "Data phase".

Refer to the section of "3-Wire Timing Diagram" for the detail timing, please.

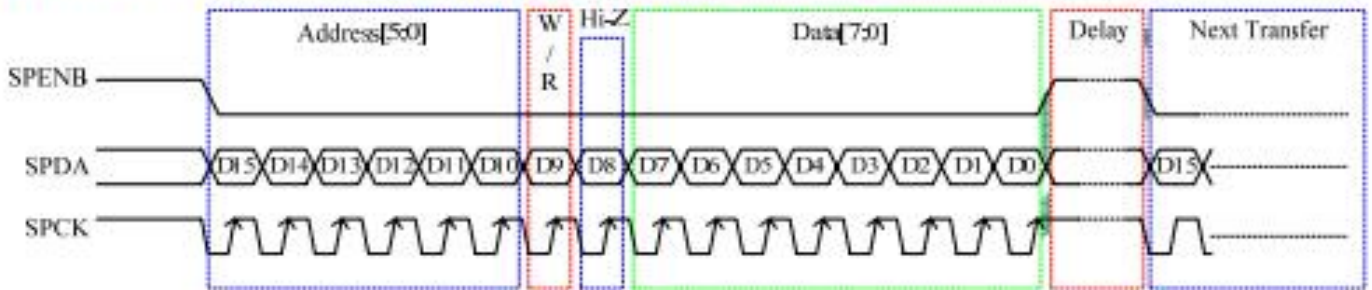

3-Wire Command Format:

Bit	Description
D15-D10	Register Address [5:0]
D9	W/R control bit. "1" for Write; "0" for Read
D8	Hi-Z bit during read mode. Any data within this bits will be ignored during write mode
D7-D0	Data for the W/R operation to the address indicated by Address phase

3-Wire Writer Format:

MSB															LSB
D15	D14	D13	D12	D11	D10	D9	D8	D7	D6	D5	D4	D3	D2	D1	D0
Register Address [5:0]						1	X	DATA (Issue by external controller)							

3-Wire Read Format:

MSB															LSB
D15	D14	D13	D12	D11	D10	D9	D8	D7	D6	D5	D4	D3	D2	D1	D0
Register Address [5:0]						0	Hi-Z	DATA (Issue by NV3035)							



7. Optical Characteristics

Items	Symbol	Condition	Min.	Typ.	Max.	Unit	Remark
Viewing angles	θ_T	Center CR \geq 10	-	55	-	Degree.	Note2
	θ_B		-	65	-		
	θ_L		-	65	-		
	θ_R		-	65	-		
Contrast Ratio	CR	$\Theta = 0$	-	350	-	-	Note1, Note3
Response Time	T_{ON}	25°C	-	25	40	ms	Note1, Note4
	T_{OFF}		-	25	40		
Chromaticity	White		0.26	0.31	0.36	-	Note1, Note5
			0.28	0.33	0.38	-	
Uniformity	U		80	-	-	%	Note1, Note6
NTSC			-	50	-	%	Note5
Luminance	L		250	300	-	nits	Note1, Note7

Test Conditions:

1. IF= 20mA (one channel), the ambient temperature is 25.
2. The test systems refer to Note 1 and Note 2.

Note 1: Definition of optical measurement system.

The optical characteristics should be measured in dark room. After 5 minutes operation, the optical Properties are measured at the center point of the LCD screen. All input terminals LCD panel must be ground when measuring the center area of the panel.

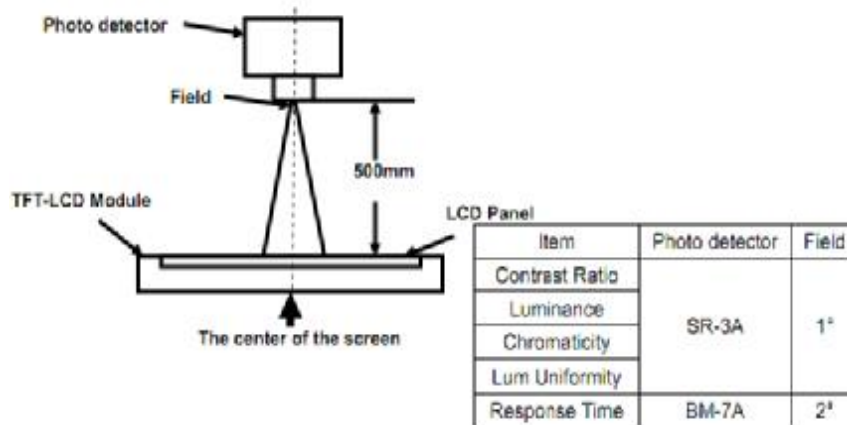

Note 2: Definition of viewing angle range and measurement system.

Viewing angle is measured at the center point of the LCD by CONOSCOPE(ergo-80).

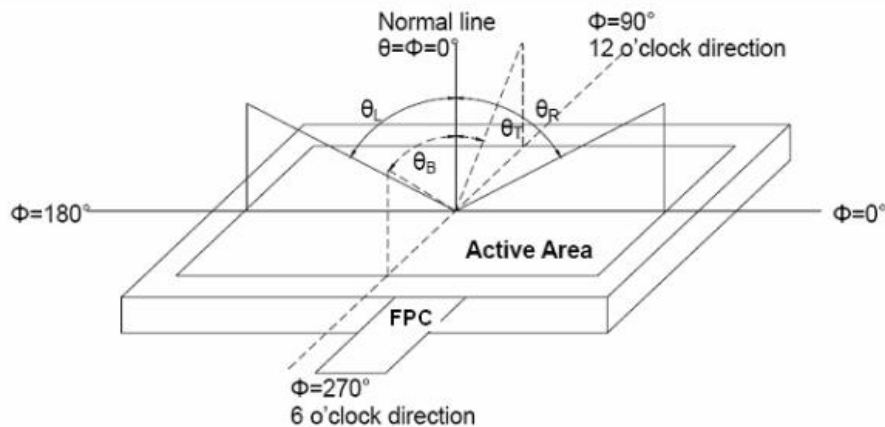

Fig. 1 Definition of viewing angle

Note 3: Definition of contrast ratio

$$\text{Contrast ratio (CR)} = \frac{\text{Luminance measured when LCD is on the "White" state}}{\text{Luminance measured when LCD is on the "Black" state}}$$

Note 4: Definition of Response time

The response time is defined as the LCD optical switching time interval between “White” state and “Black” state. Rise time (TON) is the time between photo detector output intensity changed from 90% to 10%. And fall time (TOFF) is the time between photo detector output intensity changed from 10% to 90%.

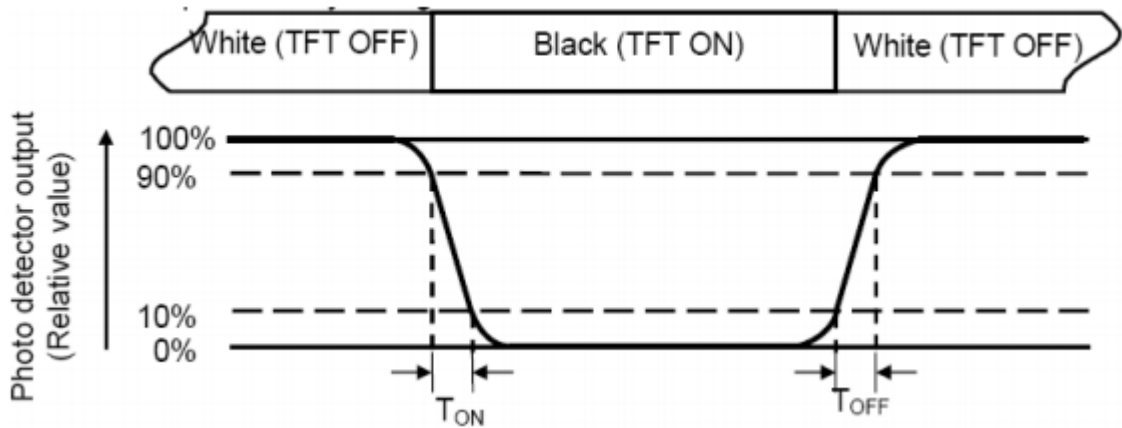

Note 5: Definition of color chromaticity (CIE1931)
Color coordinates measured at center point of LCD.

Note 6: Definition of Luminance Uniformity

Active area is divided into 9 measuring areas (Refer Fig. 2). Every measuring point is placed at the Center of each measuring area

Luminance Uniformity (U) = $L_{min} / L_{max} \times 100\%$

L-----Active area length W----- Active area width

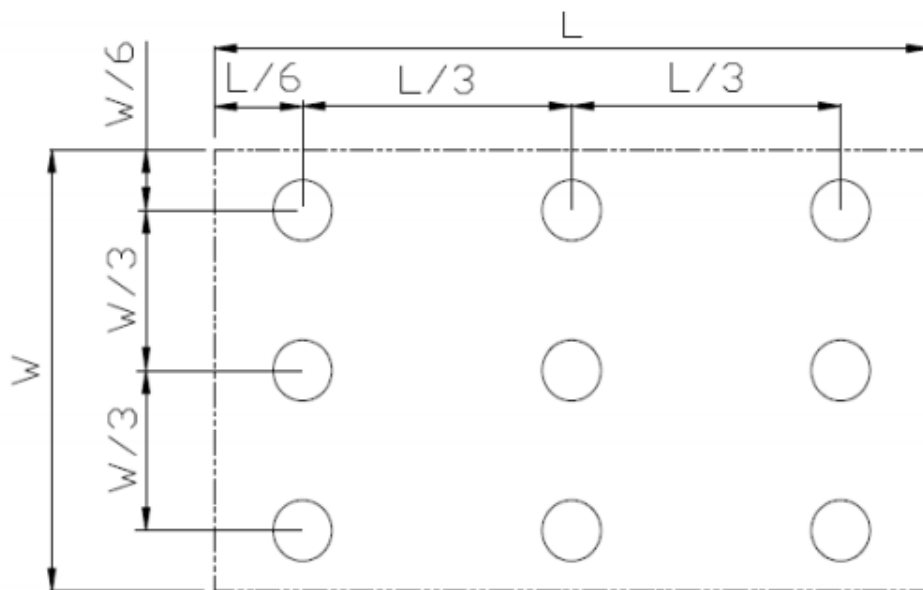

Fig. 2 Definition of uniformity

L_{max} : The measured maximum luminance of all measurement position.

L_{min} : The measured minimum luminance of all measurement position.

Note 7: Definition of Luminance:

Measure the luminance of white state at center point.



8. Environmental / Reliability Tests

No	Test Item	Condition	Remarks
1	High Temperature Operation	T _s = +70°C, 240hrs	Note 1 IEC60068-2-2, GB2423. 2-89
2	Low Temperature Operation	T _a = -20°C, 240hrs	Note 2 IEC60068-2-1 GB2423.1-89
3	High Temperature Storage	T _a = +80°C, 240hrs	IEC60068-2-2 GB2423. 2-89
4	Low Temperature Storage	T _a = -30°C, 240hrs	IEC60068-2-1 GB/T2423.1-89
5	High Temperature & Humidity Storage	T _a = +60°C, 90% RH max, 160 hours	IEC60068-2-3 GB/T2423.3-2006
6	Thermal Shock (Non-operation)	-30°C 30 min ~ +80°C 30 min Change time: 5min, 30 Cycle	Start with cold temperature, end with high temperature IEC60068-2-14, GB2423.22-87
7	Electro Static Discharge (Operation)	C=150pF, R=330 Ω, 5 points/panel Air:±8KV, 5 times; Contact: ±4KV, 5 times; (Environment: 15°C ~ 35°C, 30% ~ 60%, 86Kpa ~ 106Kpa)	IEC61000-4-2 GB/T17626.2-1998
8	Vibration (Non-operation)	Frequency range: 10~55Hz, Stroke: 1.mm Sweep: 10Hz~55Hz~10Hz 2 hours for each direction of X .Y. Z. (package condition)	IEC60068-2-6 GB/T2423.5-1995
9	Shock (Non-operation)	60G 6ms, ± X, ±Y , ± Z 3 times for each direction	IEC60068-2-27 GB/T2423.5-1995
10	Package Drop Test	Height: 80 cm, 1 corner, 3 edges, 6 surfaces	IEC60068-2-32 GB/T2423.8-1995

Note: 1. T_S is the temperature of panel's surface.

2. T_a is the ambient temperature of sample.

10. Packing

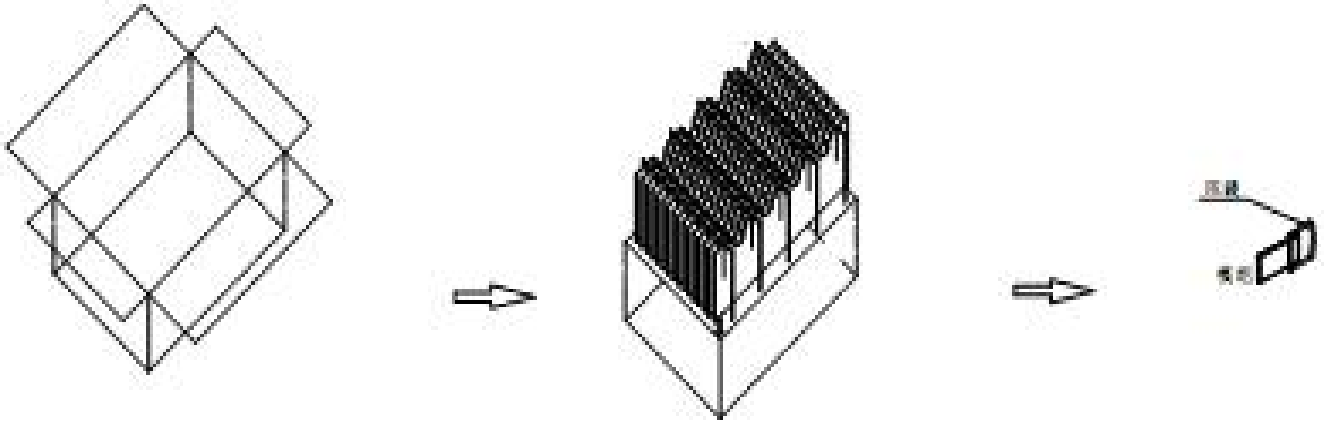

80 PCS

80*2 PCS

180 PCS

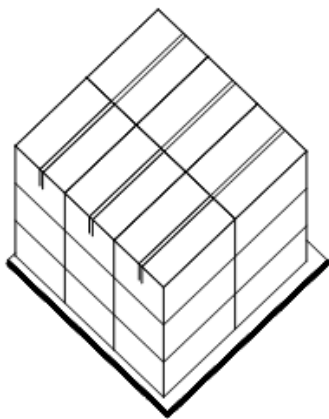
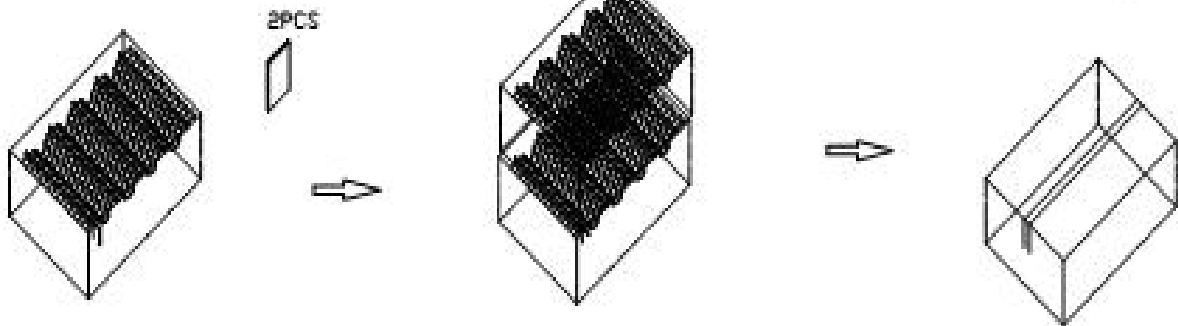



11. Precautions for Use of LCD modules

11.1 Handling Precautions

11.1.1. The display panel is made of glass. Do not subject it to a mechanical shock by dropping it from a high place, etc.

11.1.2. If the display panel is damaged and the liquid crystal substance inside it leaks out, be sure not to get any in your mouth, if the substance comes into contact with your skin or clothes, promptly wash it off using soap and water.

11.1.3. Do not apply excessive force to the display surface or the adjoining areas since this may cause the color tone to vary.

11.1.4. The polarizer covering the display surface of the LCD module is soft and easily scratched. Handle this polarizer carefully.

11.1.5. If the display surface is contaminated, breathe on the surface and gently wipe it with a soft dry cloth. If still not completely clear, moisten cloth with one of the following solvents:

- Isopropyl alcohol
- Ethyl alcohol

Solvents other than those mentioned above may damage the polarizer. Especially, do not use the following:

- Water
- Ketone
- Aromatic solvents

11.1.6. Do not attempt to disassemble the LCD Module.

11.1.7. If the logic circuit power is off, do not apply the input signals.

11.1.8. To prevent destruction of the elements by static electricity, be careful to maintain an optimum work environment.

11.1.8.1. Be sure to ground the body when handling the LCD Modules.

11.1.8.2. Tools required for assembly, such as soldering irons, must be properly ground.

11.1.8.3. To reduce the amount of static electricity generated, do not conduct assembly and other work under dry conditions.

11.1.8.4. The LCD Module is coated with a film to protect the display surface. Be care when peeling off this protective film since static electricity may be generated.

11.2 Storage Precautions

11.2.1. When storing the LCD modules, avoid exposure to direct sunlight or to the light of fluorescent lamps.

11.2.2. The LCD modules should be stored under the storage temperature range if the LCD modules will be stored for a long time, the recommend condition is:

Temperature : 0°C ~ 40°C Relatively humidity: ≤80%

11.2.3. The LCD modules should be stored in the room without acid, alkali and harmful gas.

11.3 Transportation Precautions

The LCD modules should be no falling and violent shocking during transportation, and also should avoid excessive press, water, damp and sunshine.