



APPROVAL SHEET

P/N: IE-3528Y-L-C
REV: A/0
EFFECTIVE TIME: 2015-5-5

Part Number: IE-3528Y-L-C

■ Package Dimensions And Materials

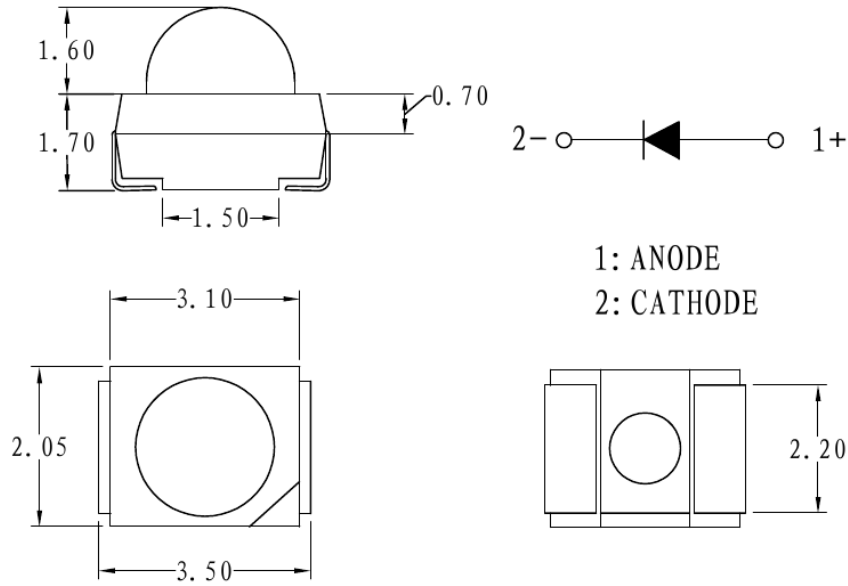

Chip		Lens Color
Material	Emitting Color	
AlGaInP	Yellow	Water Clear

(Unless otherwise noted)	(Encapsulation tolerance)	(Dimensions of produded resin flange)
± 0.1	± 0.25	Max1.0



■ Absolute Maximum Rating at TA=25° C

Item	Symbol	Absolute Maximum Rating	Unit
Forward Current	If	20	mA
Peak Forward Current	Ifp	100	mA
Reverse Voltage	VR	5	V
Power Dissipation	PD	50	mW
Electrostatic discharge	ESD	3000	V
Operation Temperature	Topr	-30 -- +80	° C
Storage Temperature	Tstg	-40 -- +80	° C
Lead Soldering Temperature	Tsol	Max. 240° C for 5sec Max	

IFP Conditions: Pulse Width ≤ 10msec duty ≤ 1/10
 Tsol Conditions: 5mm from the base of the epoxy bulb

■ Typical Optical/Electrode Characteristic

Item	Symbol	Condition	Min.	Typ.	Max.	Unit
Forward Voltage	Vf	IF=20mA	1.8	--	2.4	V
Reverse Current	Ir	Vr=5V	--	--	10	uA
50% Power Angle	2θ 1/2	IF=20mA		30		deg
Luminous Flux	Flux	IF=20mA	1	--	6	LM
The Main Wavelength	λ D	IF=20mA	585	--	595	NM
Recommend Forward Current	If (rec)	--		10-30		mA

Typical Optical/Electrode Characteristic Curves
(Ta=25°C Unless Otherwise Noted)

RELATIVE RESPONSE 100%=1.642e-G01

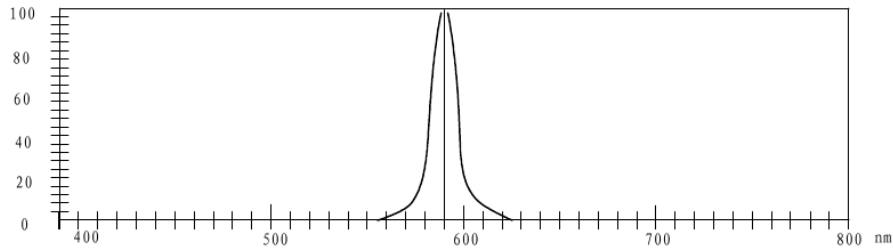

Forward Current vs. Ambient Temperature

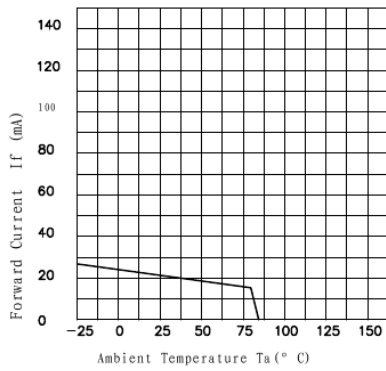

Relative Intensity vs. Ambient Temperature

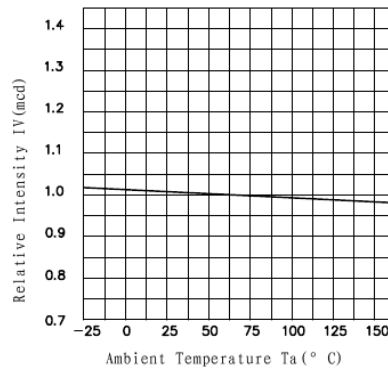

Forward Current vs. Ambient Temperature

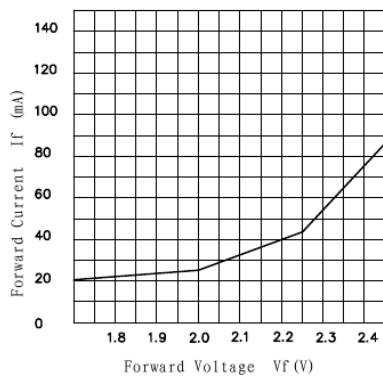

Forward Current vs. Ambient Temperature

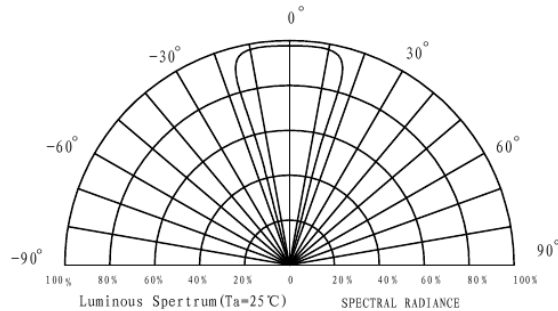
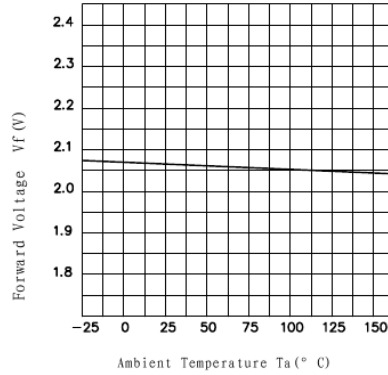

◆
Range of bins

■ VF Ranks (If=20mA)

Bin Code	Bin1	Bin2	Bin3
VF (V)	1.8-2.0	2.0-2.2	2.2-2.4

■ λ D Ranks (If=20mA)

Bin Code	Bin1	Bin2
λ D (NM)	585-590	590-595

◆

■ Tape Specifications (Units : mm)

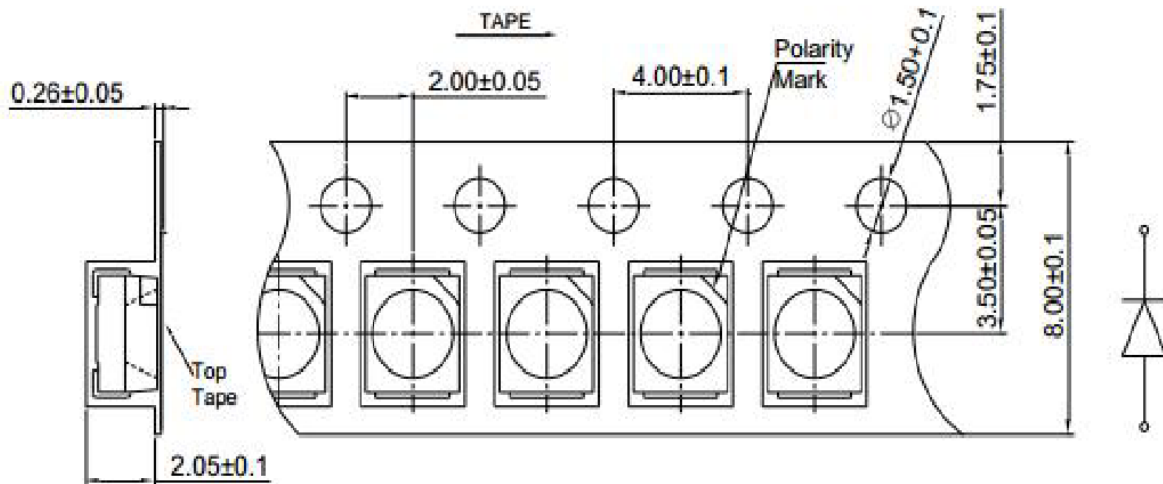

■ Reel Dimensions

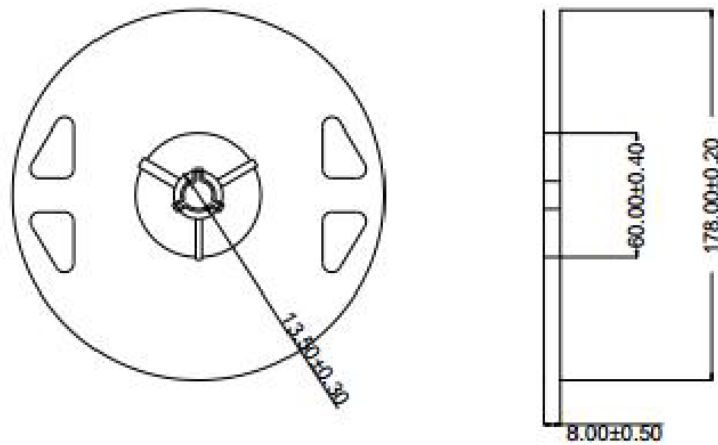

Note : Package Quantity: 2000PCS/reel

◆
Soldering Condition (Pb-Free)

1. Iron:

Soldering Iron: 30W Max
Temperature 350° C Max
Soldering Time: 3 Seconds Max (One Time)
Distance: 2mm Min (From solder joint to body)

2. Wave Soldering Profile

Dip Soldering
Preheat: 120° C Max
Preheat time: 60seconds Max
Ramp-up
2° C/sec (max)
Ramp-Down: -5° C/sec (max)
Solder Bath: 240° C Max
Dipping Time: 3 seconds Max
Distance: 2mm Min (From solder joint to body)

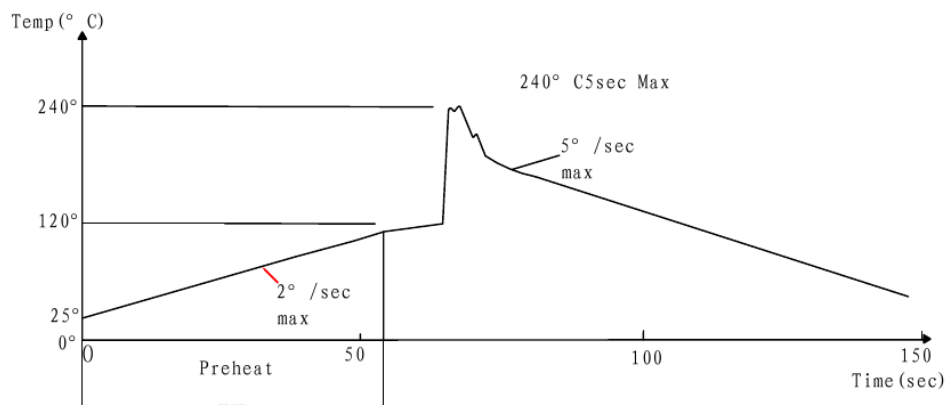

◆

■ Reliability Persult

Test Classification	Test Item	Test Condititons	Test Duration	Sample Size	AC/RE
Life Test	Room Temperatuer DC Operating Life Test	Ta=25°C ± 5°C, IF=20mA	1000Hrs	5PCS	0/1
Environment Test	Thermal Shock Test	-10°C ± 5°C ← → +100°C ± 5°C 5min. 10sec. 5min	50cycles	5PCS	0/1
	Temperature Cycle Test	-55°C ± 5°C ← → +85°C ± 5°C 30min. 5min. 30min	50cycles	5PCS	0/1
	High Temperature High Humidity test	Ta=85°C ± 5°C RH=85% ± 0.5%RH	1000Hrs	5PCS	0/1
	High Temperature Storage	Ta=100°C ± 5°C	1000Hrs	5PCS	0/1
	Low Temperature Storage	Ta=-55°C ± 5°C	1000Hrs	5PCS	0/1
Mechanical Test	Resistance to Soldering Heat	Ta=240°C ± 5°C	5sec	5PCS	0/1
	Lead Integrity	Load 2.5N(0.25kgf) 0° - 90° - 0°	3times	5PCS	0/1

■ Criteria for Judging The Damage

Item	Symbol	Test Conditions	Criteria for Judgment	
			Min.	Max.
Forward Voltage	V _F	IF=20mA		U. S. L. *1. 2
Reverse Current	I _R	V _R =5V		U. S. L. *2. 2
Luminous Intensity	I _V	IF=20mA	L. S. L. ** × 0. 7	

U. S. L. * : Upper Standard Level

L. S. L. ** : Lower Standard Level