

Specification

P/N (CUSTOMER P/N): IE-1G-123013
(DATE): 2012 4 17

Type :

IE-1G-123013



Page1 / 4

■ **产品特征 FEATURES:**

- 高可靠性和高稳定性

High intensity and reliability

- 高品质、和低功耗、低成本

High quality, Low power requirement and low cost

- IC 易兼容、易装配

IC compatible , Easy assembly

- 符合 RoHS 指令要求

Meet RoHS EU Directive

- 静电承受能力 2000V

ESD 2000V

■ **产品描述 DESCRIPTION:**

- 2.3 英寸单位数码管

2.3 Inch Single Digits Display

- 极性共阳

Common Anode

- 黑面, 白胶

Black face, white segment

- 发光颜色

Lighting Color:

1、黄绿色 **YELLOW GREEN**

2、

3、

4、

5、

- 晶片材质

Chips Materials

1、AlGaInP

2、

3、

4、

5、

Type :

IE-1G-123013



■ 产品最大绝对参数值 (Ta: 25℃) ABSOLUTE MAXIMUM RATINGS AT T_a=25℃:

PARAMETER 项目	SYMBOL 符号	Y/GREEN 黄绿色	UNIT 单位
Power Dissipation Per Segment 功耗	PAD	50	mw
Reverse Voltage Per Segment 反向耐压	VR	5	V
Continuous Forward Current Per Segment 最大额定正向流	IAF	20	mA
Peak Forward Current Per Segment(Duty-0.1,1KHz) 最大峰值正向流	IPF	60	mA
Operating Temperature Range 工作温度	TOPr	-20℃ to 80℃	
Storage Temperature Range 贮藏温度	Tstg	-30℃ to 85℃	
Lead Soldering Temperature 260℃ at 1.6mm From Body for 3 second 焊接温度 260℃/3秒 距离胶体 1.6mm 以上			

■ 产品光电参数值 (Ta: 25℃) ELECTRICAL/OPTICAL CHARACTERISTICS AT Ta=25℃:

PARAMETER 项目	SYMBOL 符号	TEST CONDITION 测试条件	Color 颜色	MIN 最小值	TYP 标准值	MAX 最大值	UNIT 单位
Forward Voltage ,Per Segment 正向压降	VF	IF=20mA	黄绿色 Y/GREEN	单芯 2.0	2.2	2.5	V
Reverse Current , Per Segment 反向漏电流	IR	VR=5V	黄绿色 Y/GREEN			50	μA
Peak Emission Wavelength 峰值波长	λp	IF=20mA	黄绿色 Y/GREEN	570	571	573	nm
Luminous Intensity Per Segment 法向光强	IV	IF=20mA	黄绿色 Y/GREEN	15	18	20	mcd

Type :
IE-1G-123013



RELATIVE INTENSITY VS. WAVELENGTH

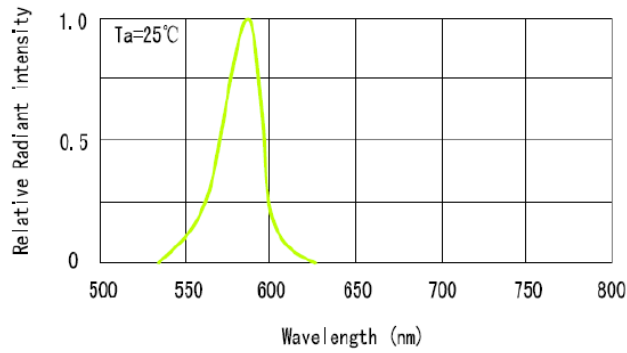

FORWARD CURRENT VS. FORWARD VOLTAGE

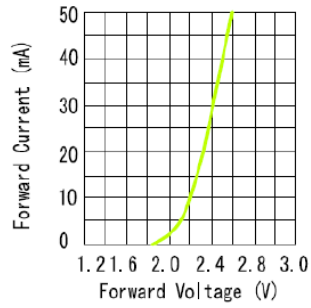

LUMINOUS INTENSITY VS. FORWARD CURRENT

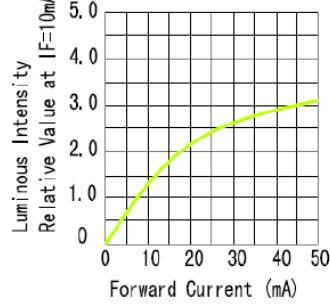

ALLOWABLE FORWARD CURRENT AMBIENT TEMPERATURE

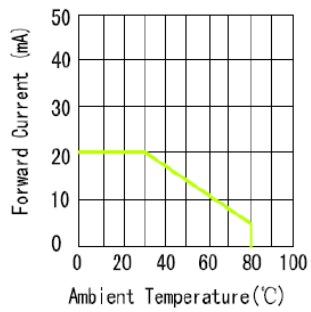

LUMINOUS INTENSITY VS. AMBIENT TEMPERATURE

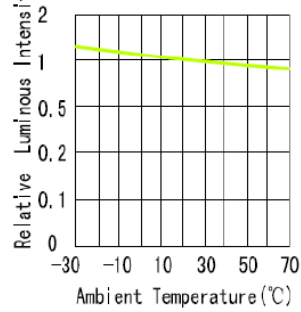

Type :
IE-1G-123013

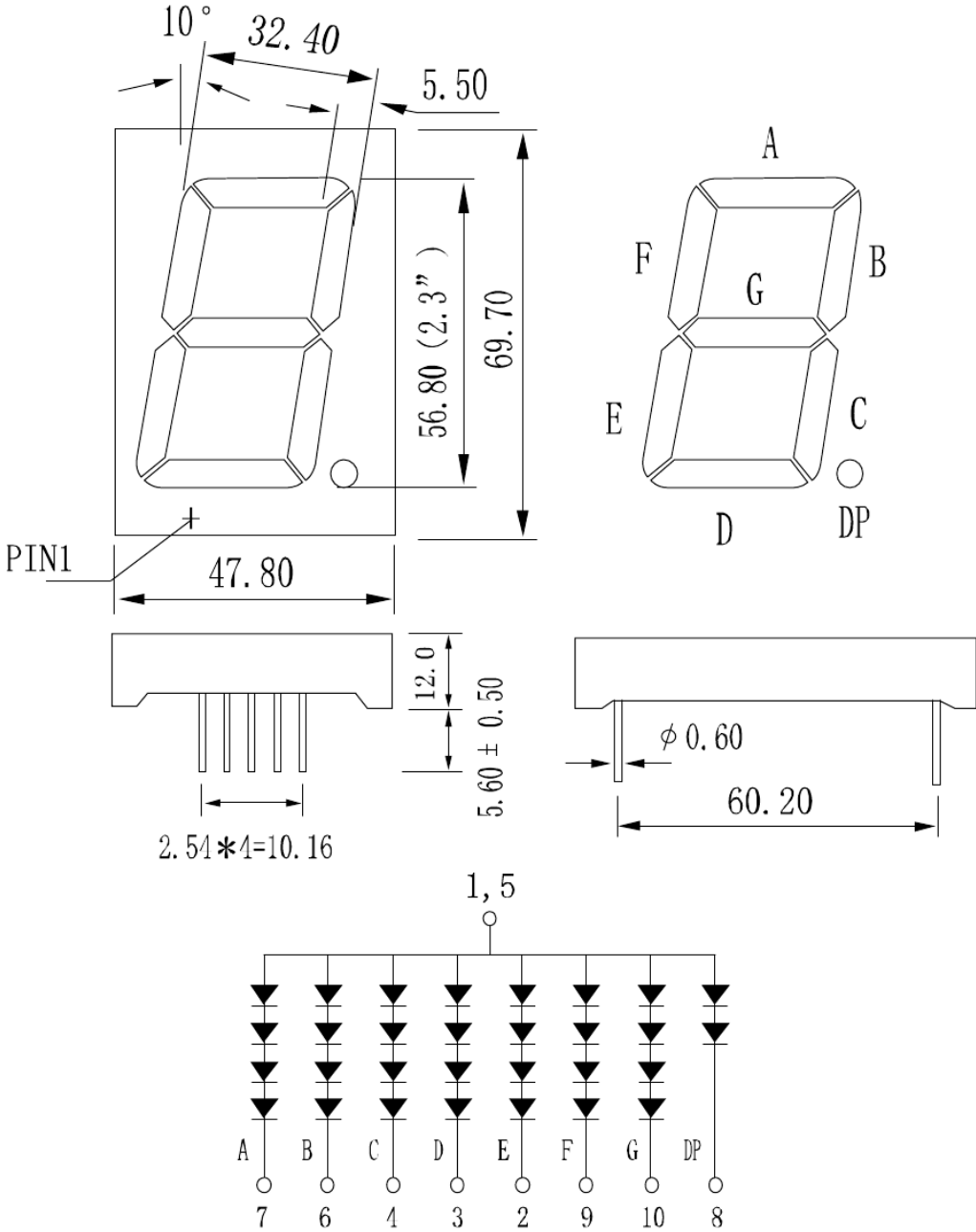

NOTES : 1. All dimensions are in millimeters. (inches)

2. Tolerance is ± 0.25(0.010") unless otherwise specified.