Product Specification Report

Customer Name:					
Customer NO.:					
Product Name:			2835 LED		
Product Type:			IE-2835WC-HB25-R95		
Date Prepared:			2019-1-10		
Approval			Customer's Approval		
Development	Approved	Marketing Dept	Confirmed by	Approved	Purchasing Dept
Judge outcome			Judge outcome		

SURFACE MOUNT LED LAMPS

2835 LED

Product Type IE-2835WC-HB25-R95

Package Dimensions

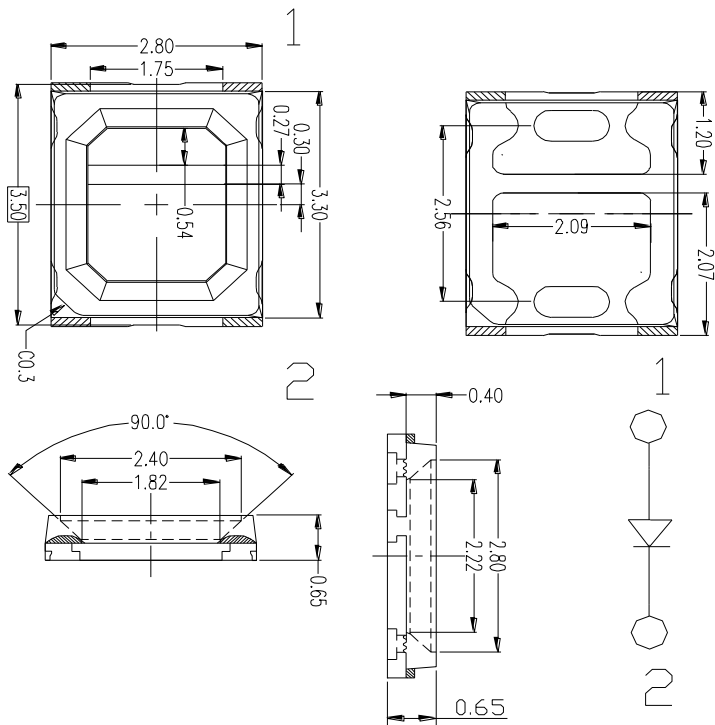

Recommended Soldering Pattern

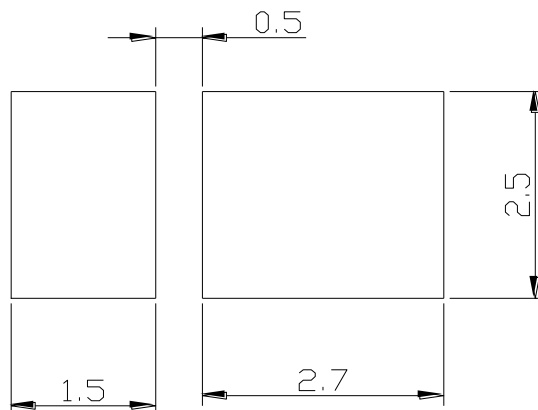

NOTES) :

- 1、 All dimensions are in millimeters
- 2、 Tolerances are ± 0.1 mm unless otherwise note.

SURFACE MOUNT LED LAMPS

Product Type IE-2835WC-HB25-R95

Absolute maximum ratings

(Ta=25°C)

Parameter	Symbol	Value	Unit
Forward current	I _f	60	mA
Reverse voltage	V _r	5	V
Power dissipation	P _d	185	mW
Operating temperature range	T _{op}	-25~+80	°C
Storage temperature range	T _{stg}	-30~+85	°C
Peak pulsing current (1/8 duty f=1KHz)	I _{fp}	90	mA
Junction Temperature	T _j	115	°C/W
Electrostatic Discharge(HBM)	ESD	1000	V

Electro-Optical characteristics

(TA=25°C)

Parameter	Test Condition	Symbol	Value			Unit
			Min	Typ	Max	
Color Temperature	I _F =60mA	CCT	6000	--	6500	K
Forward voltage	I _F =60mA	V _f	2.8	--	3.2	V
luminous flux	I _F =60mA	φ	24	--	26	LM
Viewing angle at 50% IV	I _F =60mA	2θ1/2	--	120	--	Deg
Dominant wavelength	I _F =60mA	λ _d	--	--	--	nm
Reverse current	V _r =5V	I _r	--	5	--	μA
Color Rendering Index	I _F =60mA	CRI	--	95	--	Ra

SURFACE MOUNT LED LAMPS

Product Type IE-2835WC-HB25-R95

Typical photo-electricity characteristic curve chart

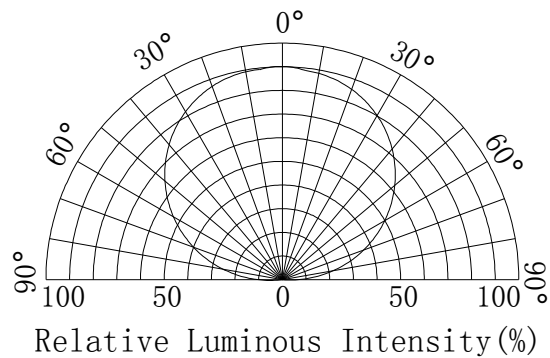
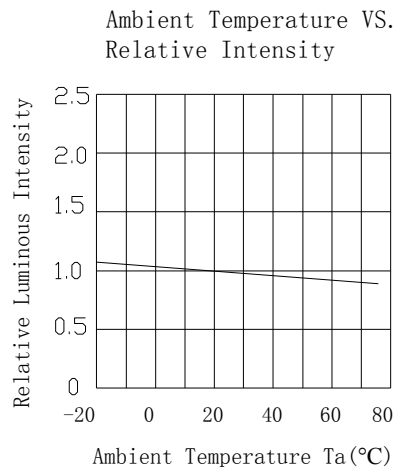
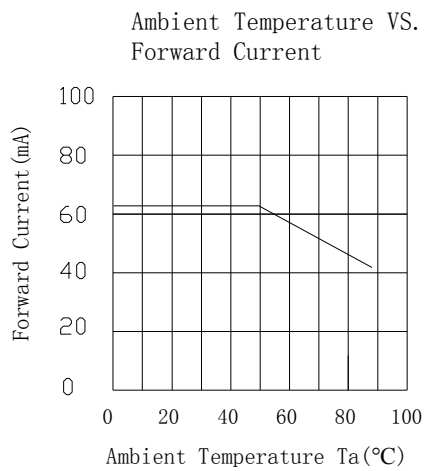
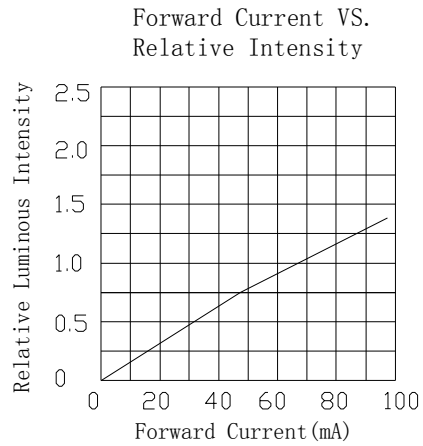
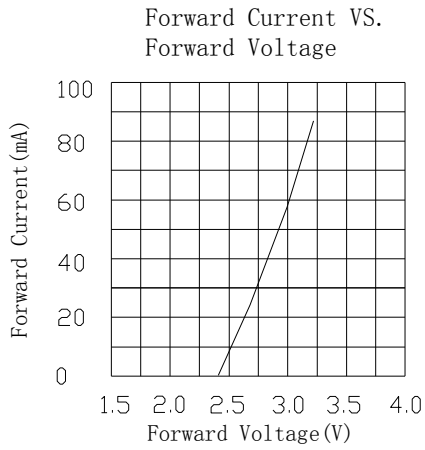

SURFACE MOUNT LED LAMPS

Product Type IE-2835WC-HB25-R95

Typical photo-electricity characteristic curve chart

CIE 1931 xy CHROMATICITY DIAGRAM

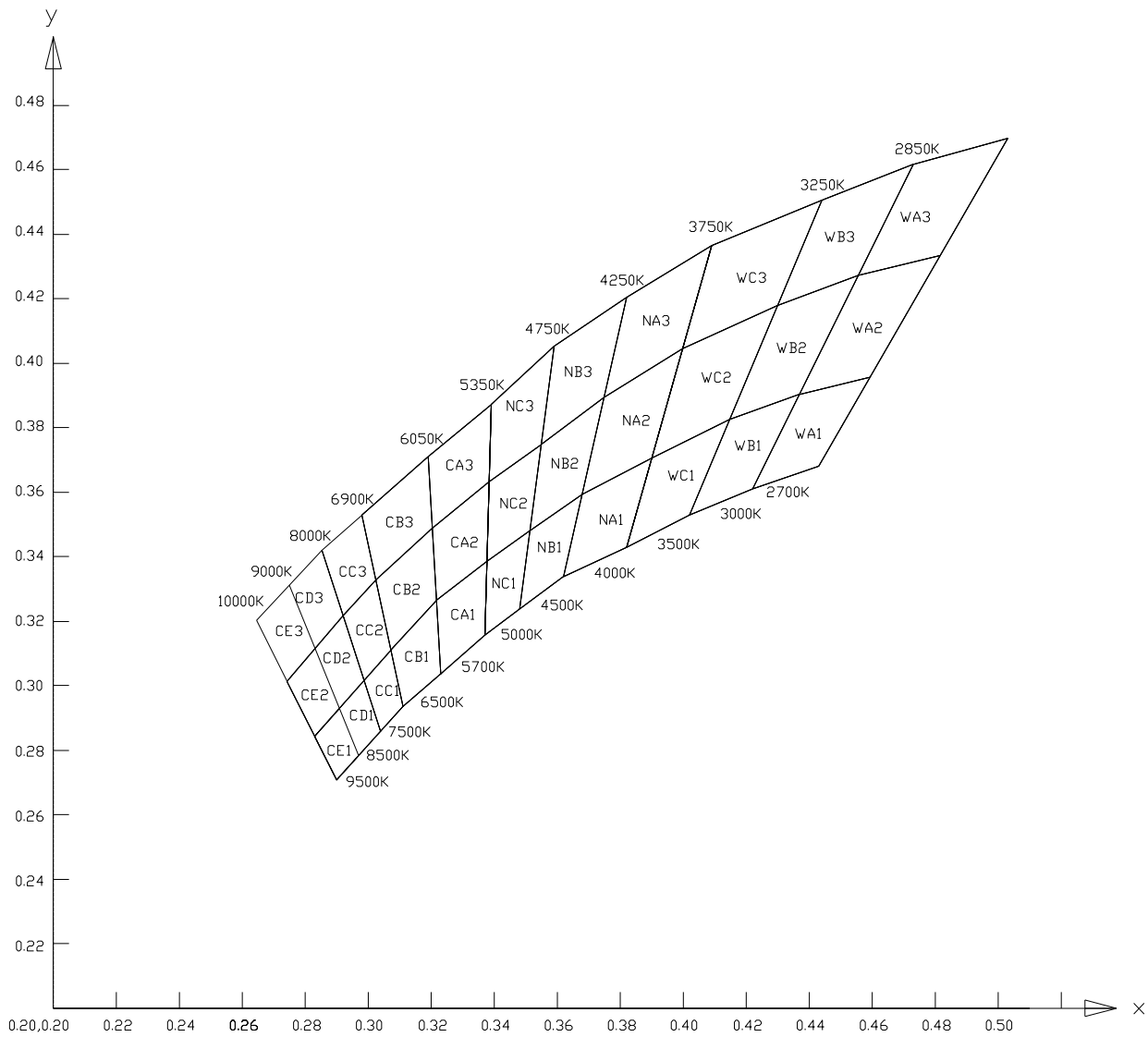

SURFACE MOUNT LED LAMPS

Test items and results of reliability

Type	Test item	Standard	Test Conditions	Note	Quantity	Number of Damaged
Environmental Sequence	Temperature Cycle	JIS C 7021 (1977)A-4	-25°C 30min ↑↓5min 80°C 30min	100 cycle	22	0
	Thermal Shock	MIL-SLD-107D	-25°C 15min ↑↓5min 80°C 15min	50cycle	22	0
	High Humidity Heat Cycle	JIS C 7021 (1977)A-5	30°C (<=) 65°C 90%RH 24hrs/1cycle	10 cycle	22	0
	High Temperature Storage	JIS C 7021 (1977)B-10	T _a =80°C	1000hrs	22	0
	Humidity Heat Storage	JIS C 7021 (1977)B-11	T _a =60°C RH=90%	1000hrs	22	0
	Low Temperature Storage	JIS C 7021 (1977)B-12	T _a =-30°C	1000hrs	22	0
Operation Sequence	Life Test	JIS C 7035 (1985)	T _a =25°C I _F =60mA	1000hrs	22	0
	High Humidity Heat Life Test	□	60°C RH=90% I _F =60mA	500hrs	22	0
	Low Temperature Life Test	□	T _a =-25°C I _F =60mA	1000hrs	22	0

Refer to reliability test standard specification for in this line.

Criteria For Judging Damage

Test Item	Symbol	Condition	Criteria
Forward Voltage	V _F	I _F =I _{FT}	Initial Data±10%
Reverse Current	I _R	V _R =5V	I _R ≤ 10μA
Luminous Intensity	I _V	I _F =I _{FT}	Average I _V degradation ≤ 30% Single LED I _V degradation ≤ 50%
Resistance to Soldering Heat	--	--	Material without internal cracks, no material between stripped, no dead light.

*

The technical information shown in the data sheets are limited to the typical characteristics and circuit examples of the referenced products. It does not constitute the warranting of industrial property nor the granting of any license.

SURFACE MOUNT LED LAMPS

Product Type IE-2835WC-HB25-R95

Guideline for Soldering

1、

Reflow Soldering: Use the conditions shown in the under Figure of Pb-Free Reflow Soldering.

SMD-Reflow Soldering Profile for lead free soldering(Acc.to J-STD-020B)

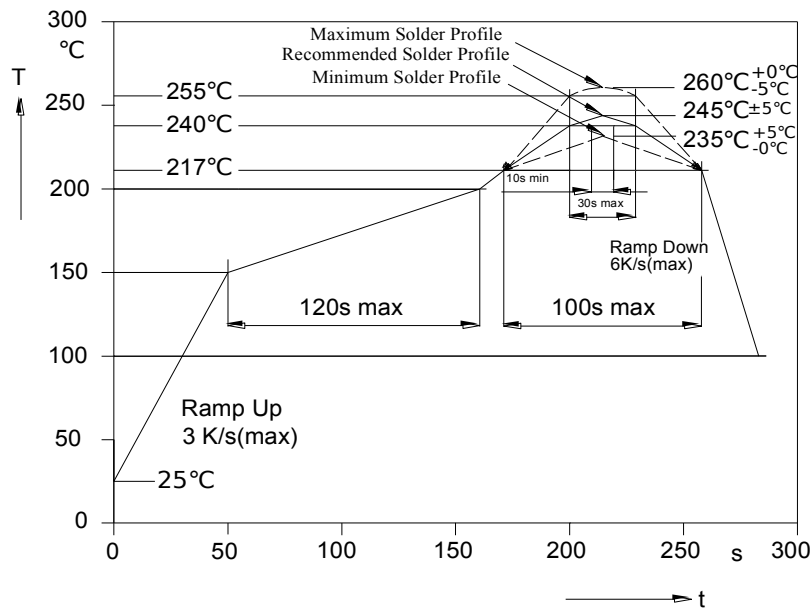

Remark: If not lead free soldering, the recommended solder profile is 230 °C and max solder profile is 245 °C.

2、

Hand Soldering

1)、

A soldering iron of less than 20W is recommended to be used in Hand Soldering. Please keep the temperature of the soldering iron under 360 °C while soldering. Each terminal of the LED is to go for less than 3 seconds and for onetime only.

2)、

Be careful because the damage of the product is often started at the time of the hand soldering.

3、

Cleaning

1

It is recommended that alcohol be used as a solvent for cleaning after soldering. Cleaning is to go under 30 °C for 3 minutes or 50 °C for 30 seconds. When using other solvents, it should be confirmed beforehand whether the solvents will dissolve the package and the resin or not.

2

Ultrasonic cleaning is also an effective way for cleaning. But the influence of Ultrasonic cleaning on LED depends on factors such as ultrasonic power. Generally, the ultrasonic power should not be higher than 300W. Before cleaning, a pre-test should be done to confirm whether any damage to LEDs will occur.

SURFACE MOUNT LED LAMPS

Product Type IE-2835WC-HB25-R95

Tape and Packaging

1 Tape leader and reel

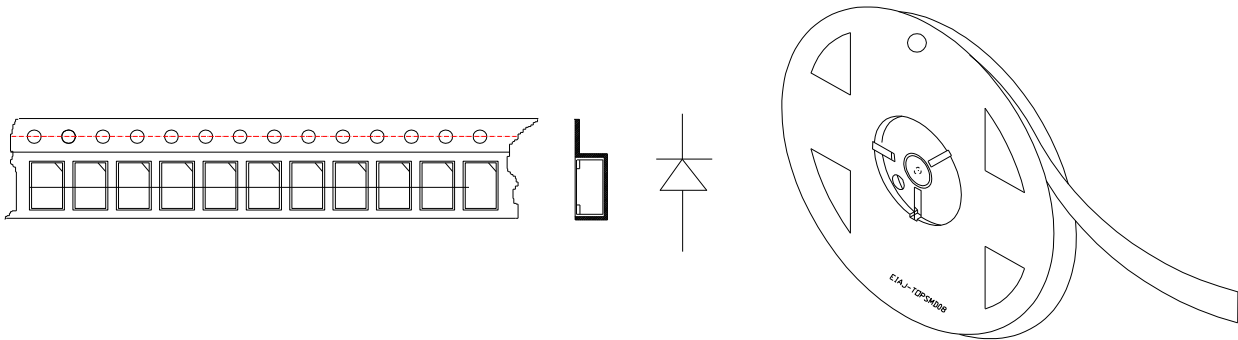

2. Moisture Resistant Packaging

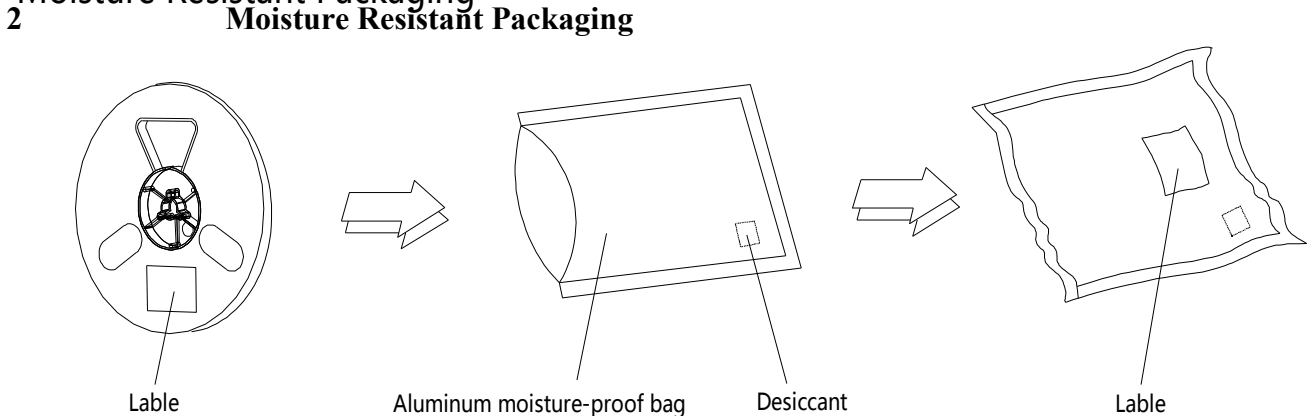

3 Cautions

1)、

The encapsulated material of the LEDs is silicone. Therefore the LEDs have a soft surface on the top of package. The pressure to the top surface will be influence to the reliability of the LEDs. Precautions should be taken to avoid the strong pressure on the encapsulated part. So when use the picking up nozzle, the pressure on the silicone resin should be proper.

2)、

The outer diameter of the SMD pickup nozzle should not exceed the size of the LED to prevent air leaks. The inner diameter of the nozzle should be as large as possible. pliable material is suggested for the nozzle tip to avoid scratching or damaging the LED surface during pickup.

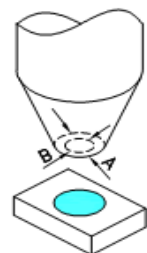

SURFACE MOUNT LED LAMPS

Product Type IE-2835WC-HB25-R95

Handling Precautions

- 1、 Handle the component along the side surface by using forceps or appropriate tools; do not directly touch or Handle the silicone lens surface, it may damage the internal circuitry.

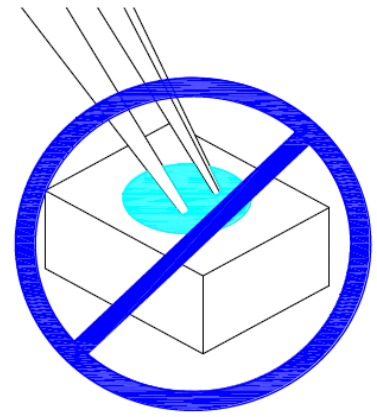
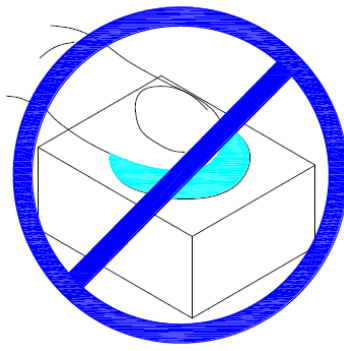
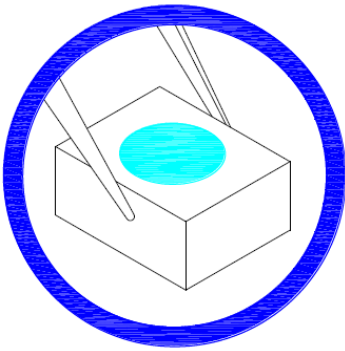

- 2、 Do not stack together assembled PCBs containing LEDs.
PH<7
Impact may scratch the silicone lens or damage the internal circuitry

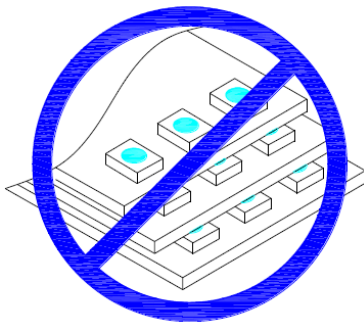

- 3 Not suitable to operate in acidic environment,

