SPECIFICATION FOR LCD MODULE

Customer : _____

Product Model: IE-SN-1110BH03R24-CWRP-1

Sample code: _____

Designed by	Checked by	Approved by

Final Approval by Customer

<input type="checkbox"/> LCM Machinery OK Checked By _____ <input type="checkbox"/> LCM Display OK Checked By _____	<input type="checkbox"/> LCM OK <input type="checkbox"/> NG, Problem survey: Approved By _____
--	--

※The specification of "TBD" should refer to the measured value of sample . If there is difference between the design specification and measured value, we naturally shall negotiate and agree to solution with customer.

2 Scope

This specification applies to the TFT LCD module which is designed and manufactured for InterElcom.
It is capable of using 262k colors mode 24bit parallel bi-directional interface.

3 Normative Reference

GB/T4619-1996 《Liquid Crystal Display Test Method》

GB/T2424 《Basic environmental Testing Procedures for Electric and Electronic Products.》

GB/T2423 《Basic Testing Procedures for Electric and Electronic Products》

IEC61747-1 《SIXTH PART GB2828`2829-87 《National Standard of PRC》

4 Definitions

4.1 Definitions of Vop

The definitions of threshold voltage Vth1, Vth2 the following typical waveforms are applied on liquid crystal by the method of equalized voltage for each duty and bias.

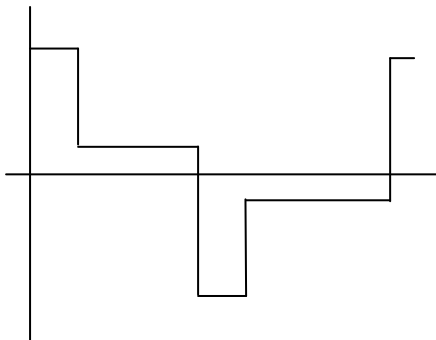

【 selected waveform 】

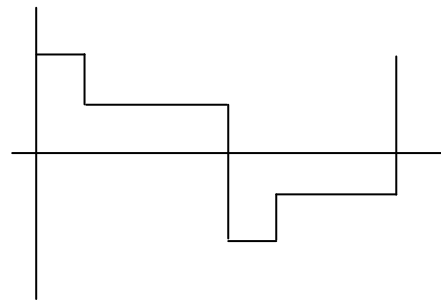

【 non-selected waveform 】

① Vth1: The voltage which the brightness of segment indicates 50% of saturated value on the conditions of selected waveform

($f_i=80\text{Hz}$, $\Phi=10^\circ$ $\theta=270^\circ$ at 25°C)

② Vth2: The voltage which the brightness of segment indicates 50% of saturated value on the conditions of non-selected waveform

($f_i=80\text{Hz}$, $\Phi=10^\circ$ $\theta=270^\circ$ at 25°C)

③ Vop: $(V_{th1}(50\%)+V_{th2}(50\%))/2$ ($f_i=80\text{Hz}$, $\Phi=10^\circ$ $\theta=270^\circ$ at 25°C)

4.2 Definition of Response Time Tr, Td

① Tr: The time required which the brightness of segment becomes 10% from 100% when waveform is switched to selected one from non-selected one. ($f_i=80\text{Hz}$, $\Phi=10^\circ$ $\theta=270^\circ$ at 25°C)

②Td: The time required which the brightness of segment becomes 90% from 10% when waveform is switched to selected one from selected one. ($f_f=80\text{Hz}$, $\Phi=10^\circ$, $\theta=270^\circ$ at 25°C)

4.3 Definition of Contrast Ratio Cr

$$Cr=A/B$$

- ① A: Segments brightness in case of non-selected waveform
- ② B: Segments brightness in case of selected waveform

4.4 Definition of Angle and Viewing Range

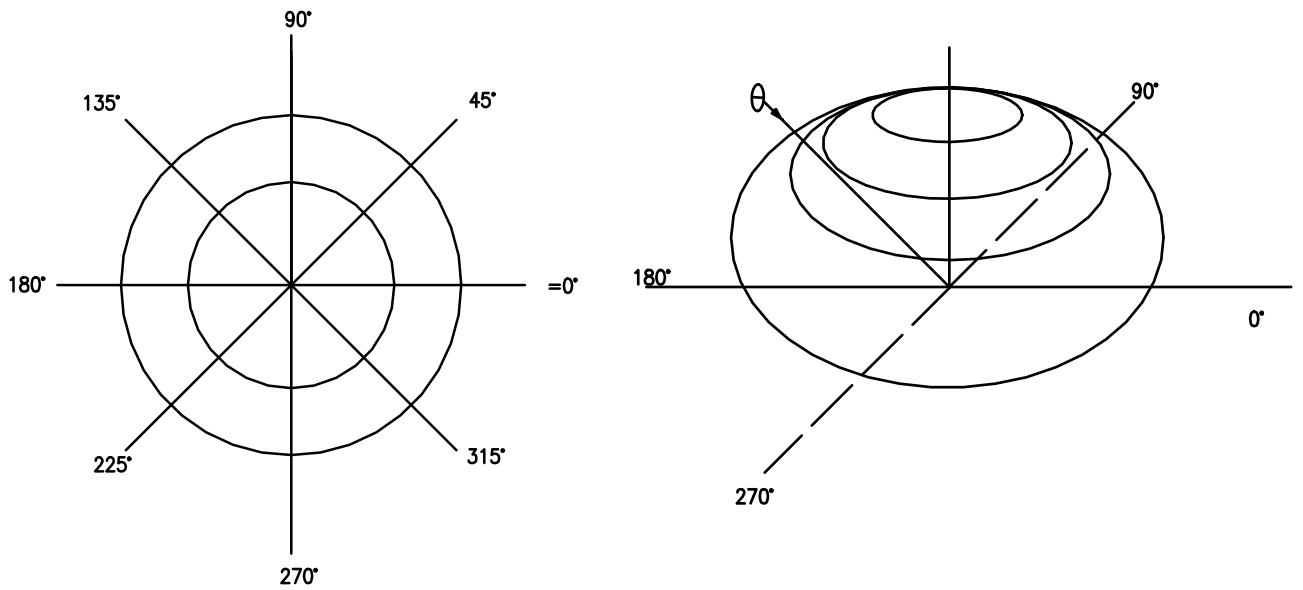

Angular Graph: Contrast Ratio

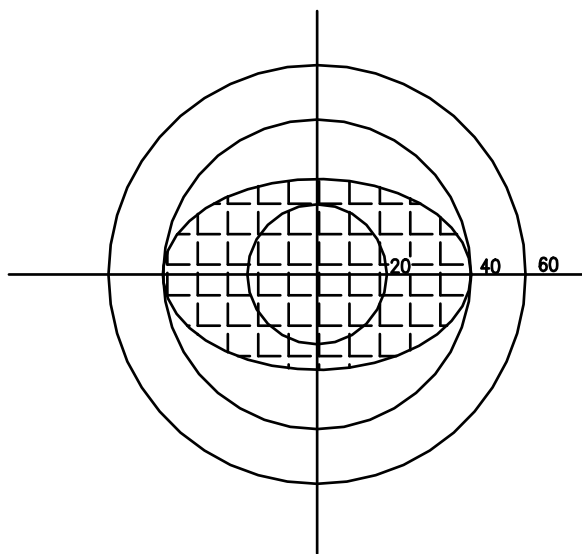

Such as:
Viewing Angle Range:
80($Cr>2$) Horizontal
70($Cr>2$) Vertical

5 Technology Specifications

5.1 Feature

This single-display module is suitable for use in Multimedia Player products. The LCD adopts one backlight with High brightness 16-lamps white LED.

- 1) Construction: 4.3" a-Si color TFT-LCD ,White LED backlight, FPC and TP.
- 2) LCD:
 - 2.1 Amorphous-TFT 4.3-inch display, transmissive, normally white type.
 - 2.2 480(RGB)×272 dots Matrix.
 - 2.3 Narrow-contact ledge technique.
 - 2.4 LCD Driver IC:
- 3) Low cross talk by frame rate modulation.
- 4) 262K Color ,24bit RGB interface.
- 5) Video signal interface: Parallel RGB .

5.2 Mechanical Specifications

Item	Specifications	Unit
Module dimension	105.5x67.2x2.95	mm
TP outline	with TP	mm
TP(V.A)	114.70x80.70	mm
TP(A.A)	----	mm
Active area	95.04(W) x53.86 (H)	mm
Pixel size	0.066x0.198	mm
Resolution	480(RGB) × 272	pixel

5.3 Absolute Max. Rating

Item	Symbol	Value			Unit	Remark
		Min	typ	Max		
power supply	VCC	1.8	3.3	3.6	V	
Input high voltage	V _{IH}	0.8VCC	-	VCC	V	
Input low voltage	V _{IL}	0	-	0.2VCC	V	
Operating temperature	T _{OPR}	-20		+70	°C	
Storage temperature	T _{STG}	-30		+80	°C	
Clock frequency	F _{CLK}	-	9	15	MHz	Note1

Note: For parallel RGB interface, maximum clock frequency is 15MHz,

For serial RGB interface, maximum clock frequency is 33MHz,

5.4 Electrical Characteristics (VSS=0V, Ta=-20 to 70°C)

Symbol	Parameter	Test condition	Spec.			Unit
			Min.	Typ.	Max.	
VDDIO	Power supply pin of IO pins	Recommend Operating Voltage Possible Operating Voltage	1.8	-	3.6	V
VCI	Booster Reference Supply Voltage Range	Recommend Operating Voltage Possible Operating Voltage	\geq VDDIO & \geq 3	-	3.6	V
I _{sleep}	Sleep mode current	-	-	50	-	μA
I _{op}	Operating mode current	VCI=3.3V	-	13	15	mA
VCL	Negative V _{CI} Output Voltage	No panel loading	- VCI	-	- VCI+0.7	V
VCIX2	V _{CIx2} primary booster efficiency ⁽¹⁾	No panel loading, ITO for V _{CIx2} , V _{CI} and V _{CHS} = 10 Ohm	5.2	5.4	5.6	V
VDC	V _{DC} Output Voltage	VDC[3:0]=1011	4.9	5	5.1	V
VGH	Gate driver High Output Voltage	No panel loading; 3x booster	84	89.5	-	%
	Booster efficiency ⁽²⁾	No panel loading; 4x booster	80	88.5	-	%
VGL	Gate driver Low Output Voltage	V _{GL} = -2 x VDC	-10	-10	-9	V
COMH	VCOM High Output Voltage ⁽³⁾	-	-3%	COMC+COMPP	3%	V
COML	VCOM Low Output Voltage ⁽³⁾	-	-3%	COMC-COMPP	3%	V
VLCD	V _{LCD} Output Voltage	VRH[5:0]=100100	4.41	4.51	4.61	V
V _{OH1}	Logic High Output Voltage	I _{out} = -100μA	0.9*V _{DDIO}	-	V _{DD}	V
V _{VD}	Source Output Voltage Deviation	-	-	±20	±30	mV
V _{OS}	Source Output Voltage Offset	-	-	-	±30	mV
V _{OL1}	Logic Low Output Voltage	I _{out} = 100μA	0	-	0.1*V _{DDIO}	V
V _{IH1}	Logic High Input voltage	-	0.8*V _{DDIO}	-	V _{DDIO}	V
V _{IL1}	Logic Low Input voltage	-	0	-	0.2*V _{DDIO}	V
I _{OH}	Logic High Output Current Source	V _{out} = VDD - 0.4V	50	-	-	μA
I _{OL}	Logic Low Output Current Drain	V _{out} = 0.4V	-	-	-50	μA
I _{oz}	Logic Output Tri-state Current Drain Source	-	-1	-	1	μA
I _{LI/ IH}	Logic Input Current	-	-1	-	1	μA

Note : (1) VCIX2 efficiency = VCIX2 / (2 x VCI) x 100%

(2) VGH efficiency = VGH / (VDC x n) x 100% (where n = booster factor)

(3) VCOML < 0V, VCOMH < VCIX2J

5.5 Optical specifications

Item	Symbol	Conditions	Specifications			Unit	Note	
			Min.	Typ.	Max.			
Transmittance	T%	Viewing normal angle $\theta_x = \theta_y = 0^\circ$	-	6.1	-	%	All left side data are based on CMO's following condition – 6 o'clock NTSC: 50% LC: TN Light : C light (Machine:BM5A) Normal Polarizer (Linear Polarizer)	
Contrast Ratio	CR		-	600	-	-		
Response Time	T_R		-	5	-	ms		
	T_F		-	15	-	ms		
Chromaticity	Red		X_R	0.590	0.620	0.650		-
			Y_R	0.314	0.344	0.374		-
	Green		X_G	0.276	0.306	0.336		-
			Y_G	0.533	0.563	0.593		-
	Blue		X_B	0.103	0.133	0.163		-
			Y_B	0.119	0.149	0.179		-
White	X_W	0.281	0.311	0.341	-			
	Y_W	0.319	0.349	0.379	-			
Viewing Angle	Hor.	θ_{x+}	-	45	-	deg.	Simulation data Reference Only	
		θ_{x-}	-	45	-			
	Ver.	θ_{y+}	-	15	-			
		θ_{y-}	-	35	-			

***Note (1) Definition of Contrast Ratio (CR):**

The contrast ratio can be calculated by the following expression.

$$\text{Contrast Ratio (CR)} = L_{63} / L_0$$

L63: Luminance of gray level 63

L0: Luminance of gray level 0

$$CR = CR(5)$$

CR (X) is corresponding to the Contrast Ratio of the point X at Figure in Note (5).

***Note (2) Definition of Response Time (T_R , T_F):**

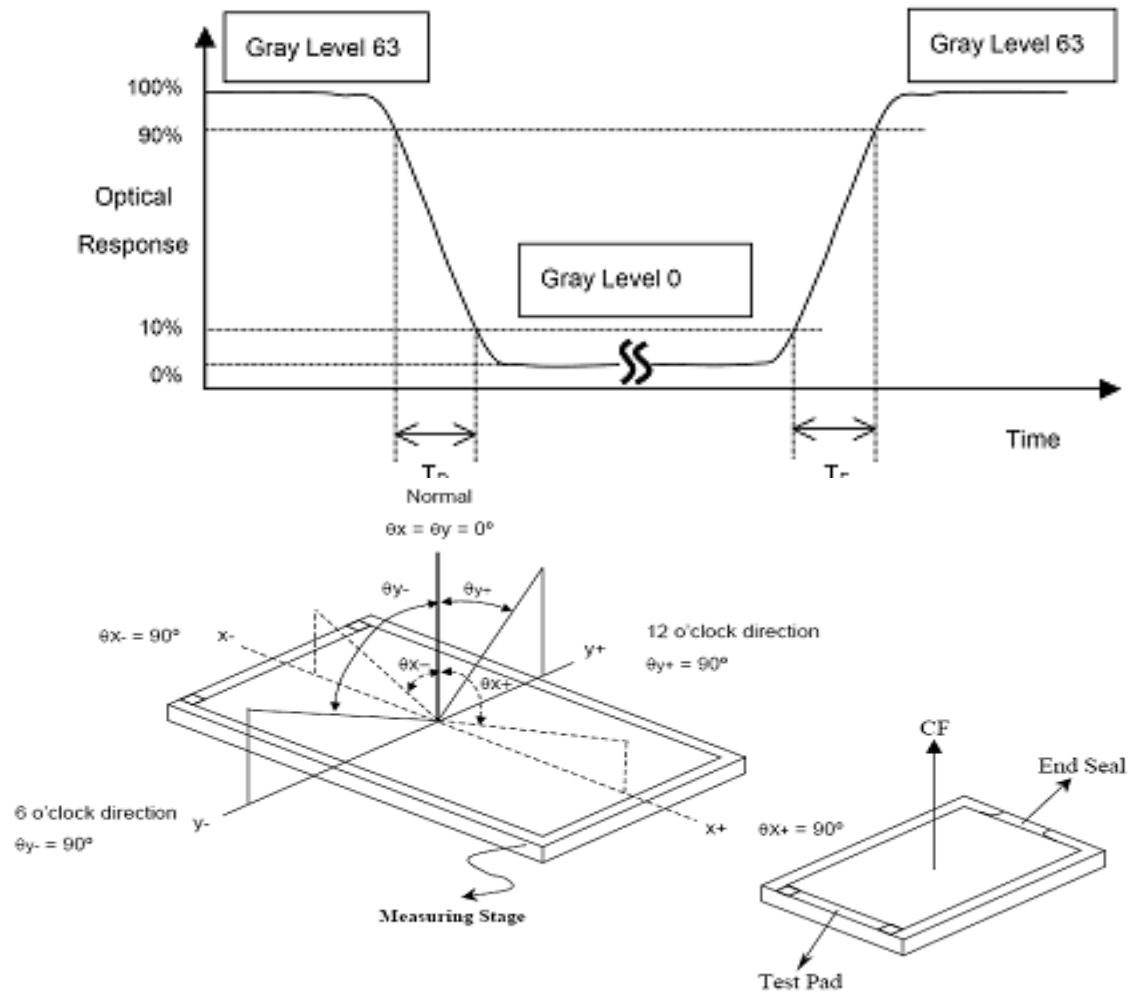

5.6 LED backlight specification(7 white chips)

Item	Symbol	Condition	Min	Typ	Max	Unit
Forward Voltage	V _f	I _f =20mA	21	22.4	23.1	V
Uniformity (with L/G)	Δ B _p	I _f =20mA		80	--	%
Luminance for LCD	L _v	I _f =20mA	300	350	-	cd/m ²

LED CIRCUIT

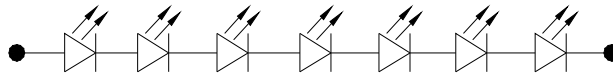

5.7 Interface Pin Connections

PIN NO.	Symbol	Description
1	LED-K	LED backlight(Cathode)
2	LED-A	LED backlight(anode)
3	GND	Ground
4	VCC	Power supply (Digital +3.0V)
5-12	R0-R7	Red Data
13-20	G0-G7	Green Data
21-28	B0-B7	Blue Data
29	GND	Ground
30	CLK	Clock signal
31	DISP	Display on/off
32	HSYNC	Horizontal sync input in RGB mode (short to GND if not used)
33	VSYNC	Vertical sync input in RGB mode (short to GND if not used)
34	DEN	Data Enable
35	NC	NC
36	GND	Ground
37	NC	No connection
38	NC	No connection
39	NC	No connection
40	NC	No connection

6 Signal timing diagram and Circuit block diagram

6.1 Circuit block diagram

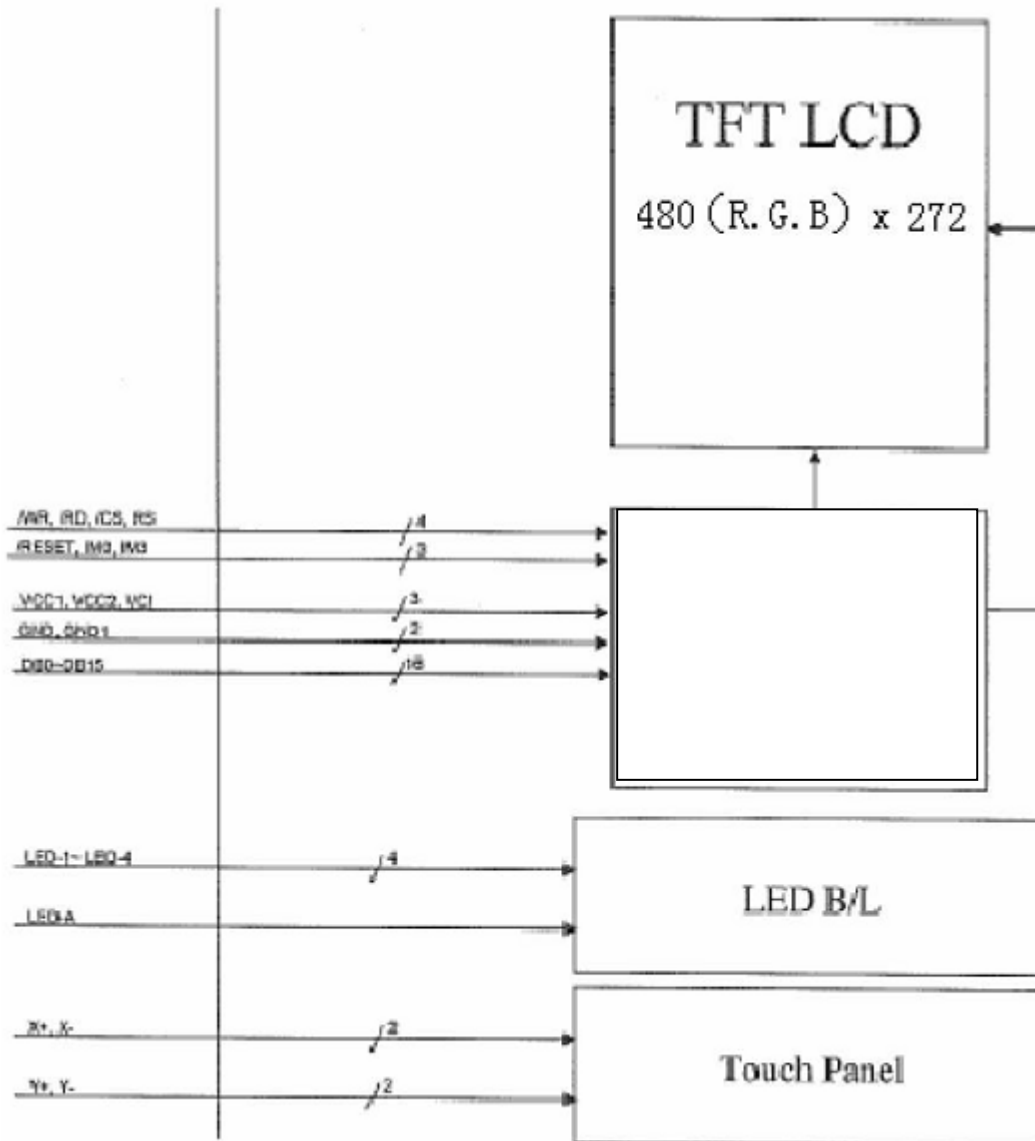

6.2 Signal Timing Diagram

6.2.1 Power ON Sequence

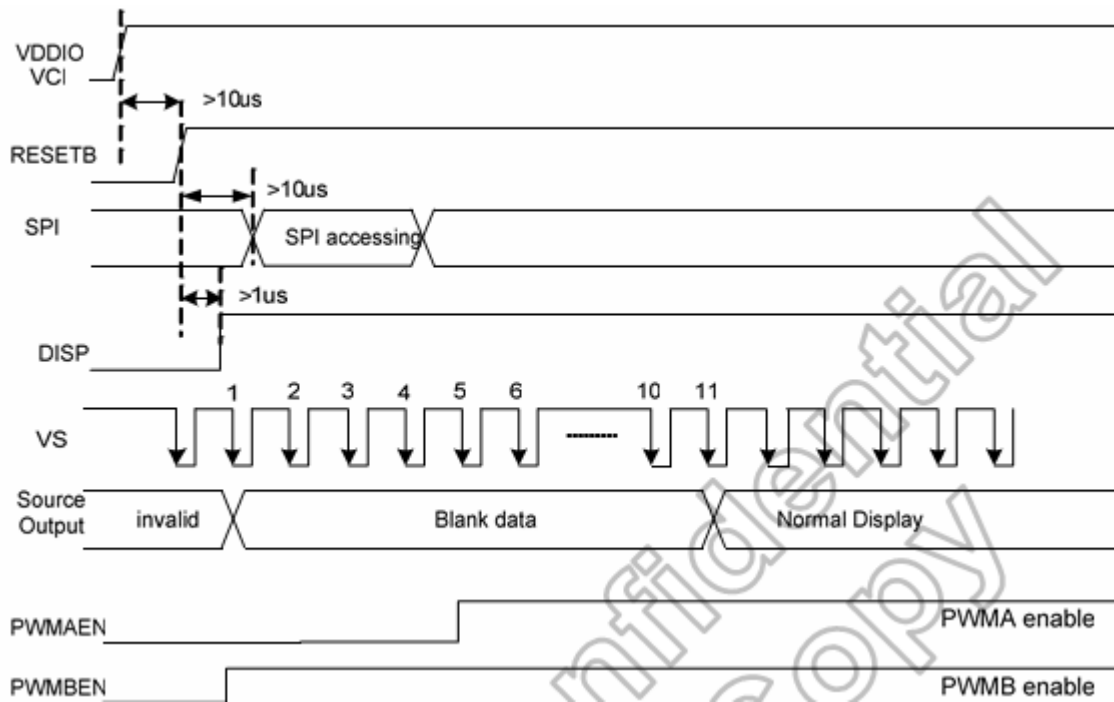

6.2.2 Power OFF Sequence

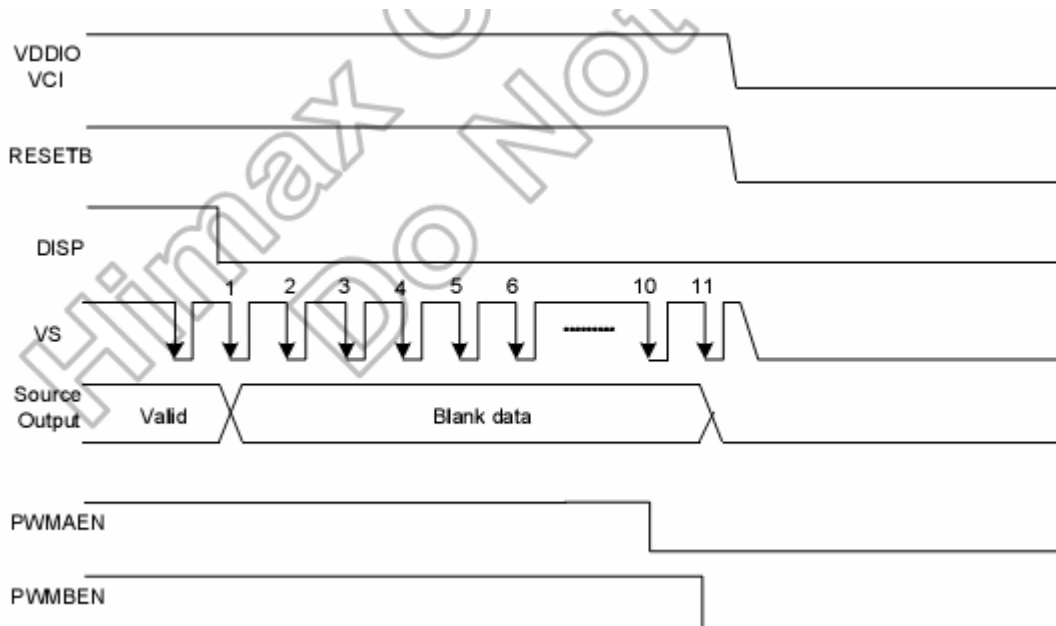

6.2.3 Timing Diagram of interface Signal

(480RGBx272, $T_A=25^{\circ}\text{C}$, $V_{DDIO}=1.8\text{V to }3.6\text{V}$, $DVSS=0\text{V}$)

Parameter	Symbol	Spec.			Unit
		Min.	Typ.	Max.	
Clock cycle	$f_{\text{CLK}}^{(1)}$	-	9	15	MHz
Hsync cycle	$1/\text{th}$	-	17.14	-	KHz
Vsync cycle	$1/\text{tv}$	-	59.94	-	Hz
Horizontal Signal					
Horizontal cycle	th	525	525	605	CLK
Horizontal display period	thd	480	480	480	CLK
Horizontal front porch	thf	2	2	82	CLK
Horizontal pulse width	$\text{thp}^{(2)}$	2	41	41	CLK
Horizontal back porch	$\text{thb}^{(2)}$	2	2	41	CLK
Vertical Signal					
Vertical cycle	tv	285	286	511	$\text{H}^{(1)}$
Vertical display period	tvd	272	272	272	$\text{H}^{(1)}$
Vertical front porch	tvf	1	2	227	$\text{H}^{(1)}$
Vertical pulse width	$\text{tvp}^{(2)}$	1	10	11	$\text{H}^{(1)}$
Vertical back porch	$\text{tvb}^{(2)}$	1	2	11	$\text{H}^{(1)}$

Note: (1) Unit: $\text{CLK}=1/f_{\text{CLK}}$, $\text{H}=\text{th}$,

(2) It is necessary to keep $\text{tvp}+\text{tvb}=12$ and $\text{thp}+\text{thb}=43$ in sync mode. DE mode is unnecessary to keep it.

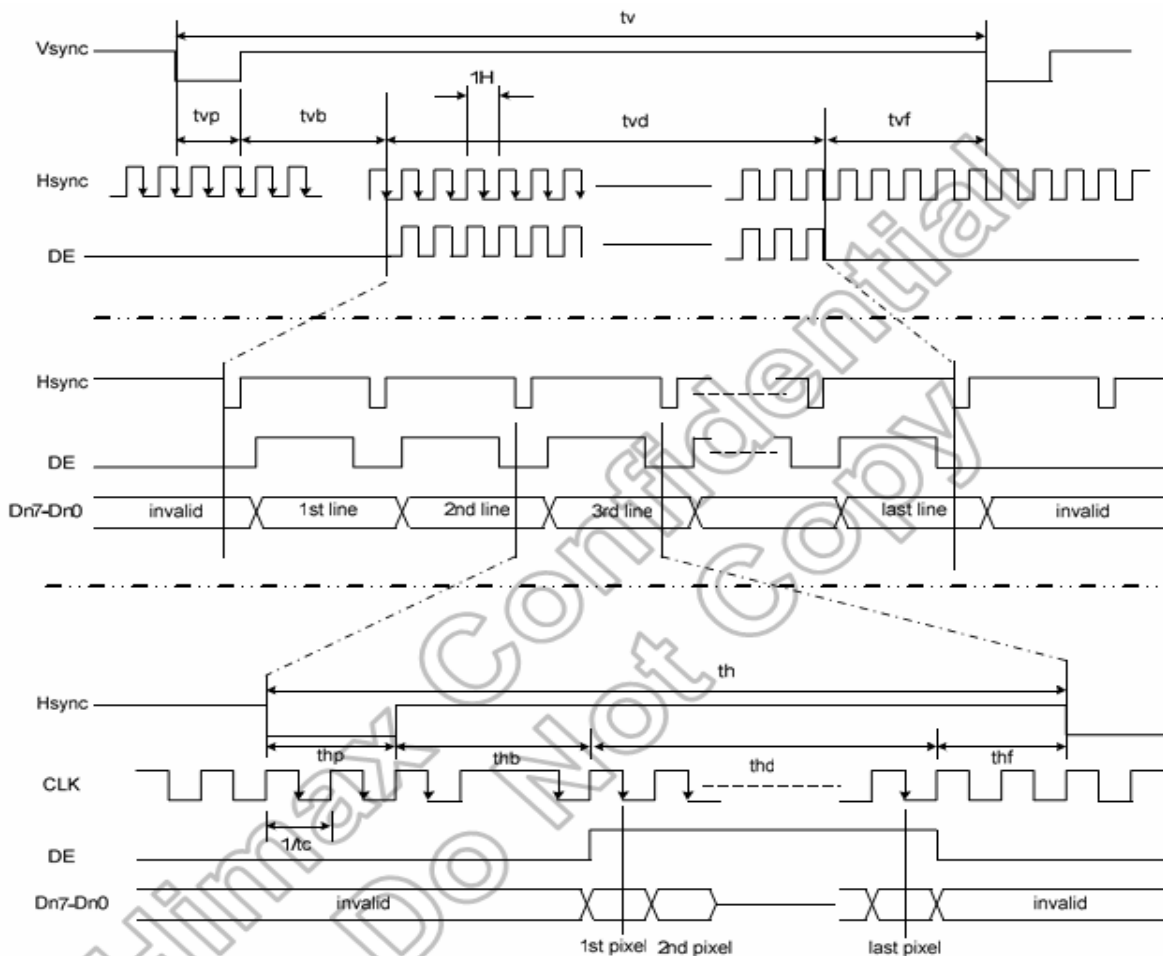

Figure 11.1 Parallel RGB Input Timing

6.2.4 Input setup Timing requirement

($T_A=25^{\circ}\text{C}$, $V_{DDIO}=1.8\text{V to }3.6\text{V}$, $DV_{SS}=0\text{V}$, $t_r^{(1)}=t_f^{(1)}=2\text{ns}$)

Parameter	Symbol	Spec.			Unit
		Min.	Typ.	Max.	
DISP setup time	t_{diss}	10	-	-	ns
DISP hold time	t_{dish}	10	-	-	ns
Clock period	$PW_{CLK}^{(2)}$	66.7	-	-	ns
Clock pulse high period	$PWH^{(2)}$	26.7	-	-	ns
Clock pulse low period	$PWL^{(2)}$	26.7	-	-	ns
Hsync setup time	t_{hs}	10	-	-	ns
Hsync hold time	t_{hh}	10	-	-	ns
Data setup time	t_{ds}	10	-	-	ns
Data hold time	t_{dh}	10	-	-	ns
DE setup time	t_{des}	10	-	-	ns
DE hold time	t_{deh}	10	-	-	ns
Vsync setup time	t_{vhs}	10	-	-	ns
Vsync hold time	t_{vhh}	10	-	-	ns

Note: (1) t_r , t_f is defined 10% to 90% of signal amplitude.

(2) For parallel interface, maximum clock frequency is 15MHz.

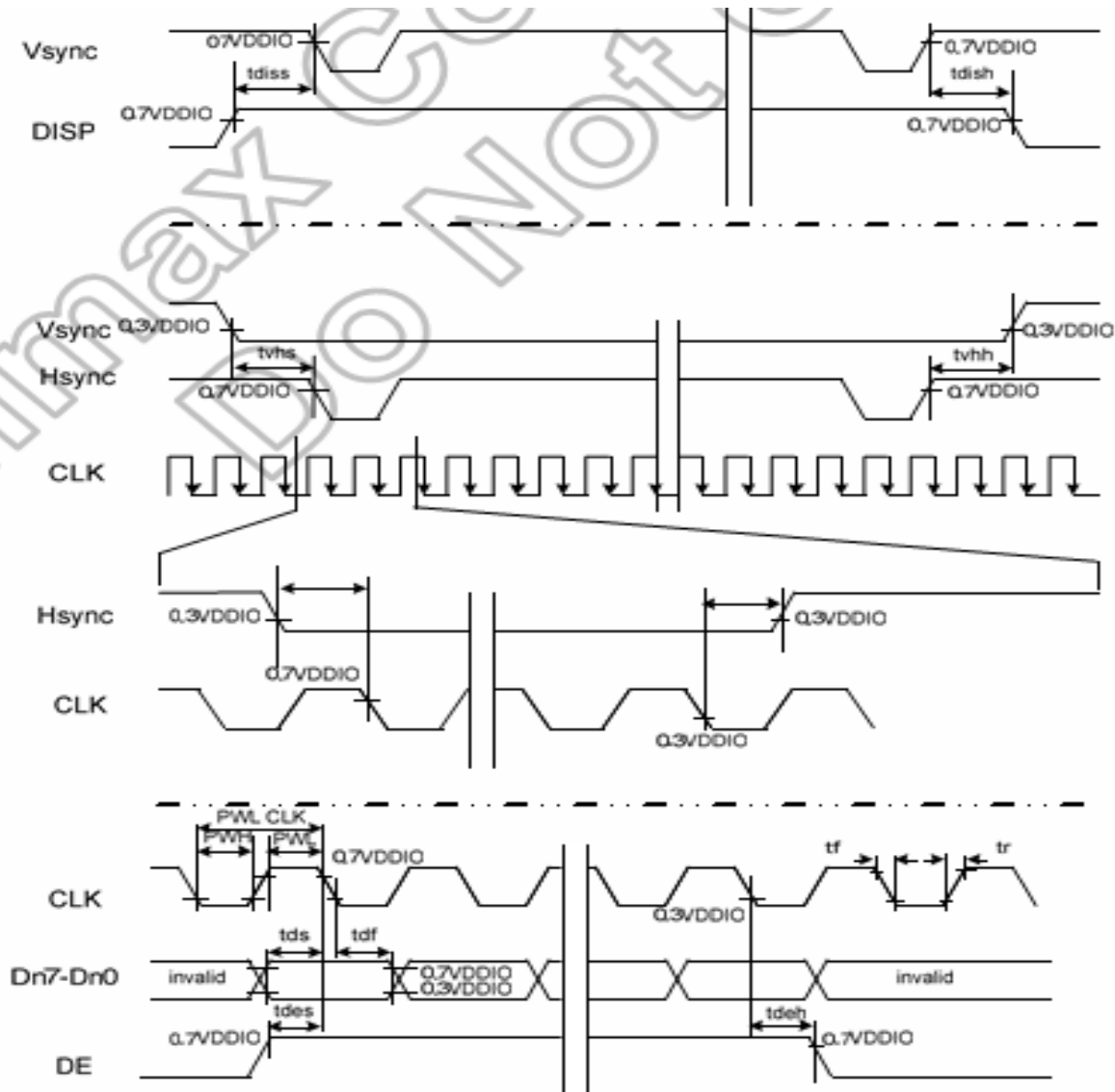

8 Write/Read SPI Timing

- Write SPI

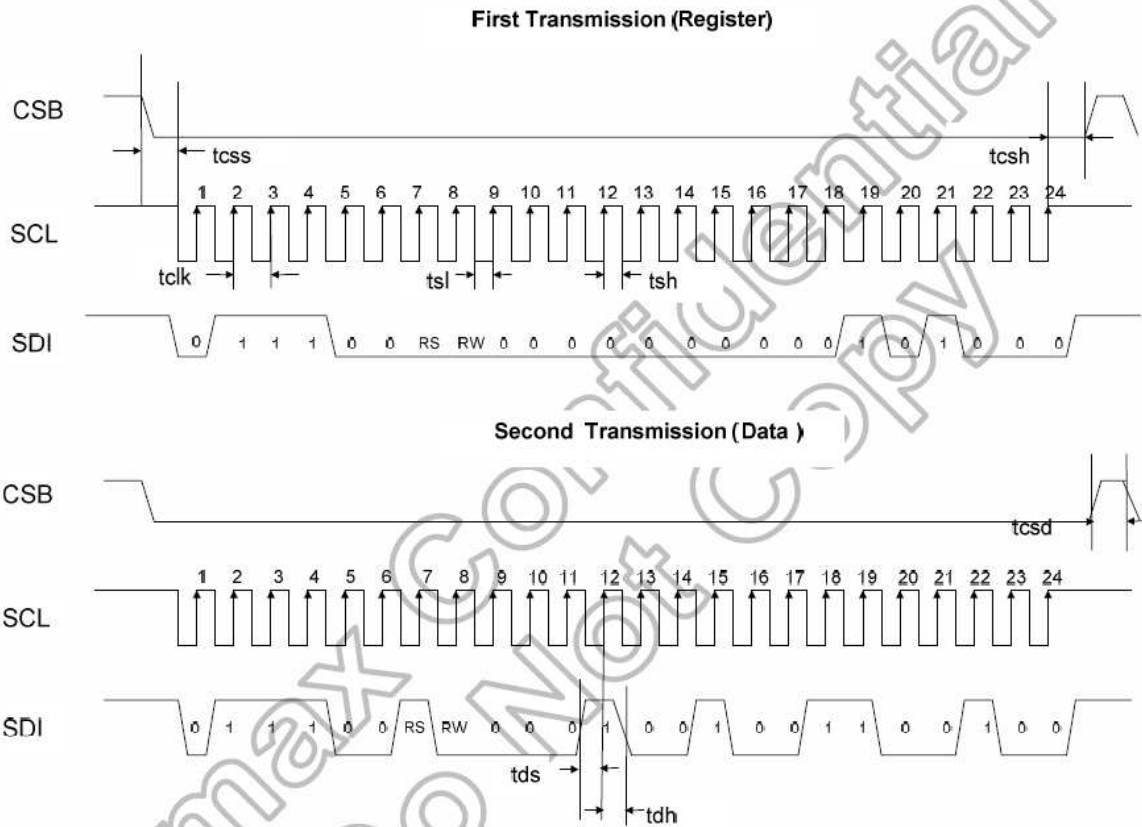

- Read SPI

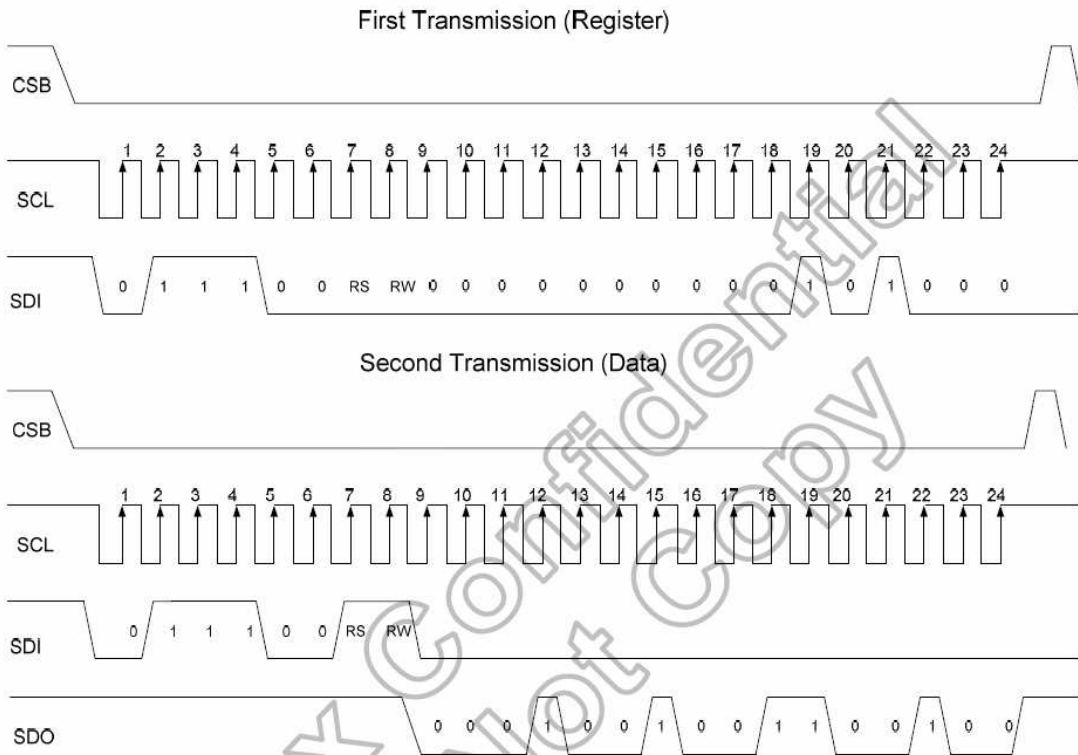

9 Reliability Test Conditions And Methods

NO	Item	Condition	Method
1	High / Low Temperature Storage	80°C/-30°C 120hrs	Check and record every 48Hrs
2	High / Low Temperature Life	70°C/-20°C 120hrs (operating mode)	Check and record every 48Hrs
3	High Temperature、High Humidity Operating	60°C,90% RH, 96Hrs	Check and record every 48hrs
4	Thermal Shock	-30°C(30Min) → 25°C(5Min) → 80°C(30Min) (conversion time, : 5 sec) 20 cycles	Each 10 cycles end , check
5	Vibration	10Hz~55Hz~10Hz Amplitude: 1.5mm 2hrs for each direction(X,Y,Z)	Each direction end, Check the Appearance and Electrical Characteristics
6	Static Electricity	Gap mood: ±1KV~±8KV (10 times air discharge with positive/negative voltage voltage gap : 1kv) Touch mood: ±1KV~±4KV	Each discharge end, Check the Electrical Characteristics
7	Curve	60 Thousand times, 40 times/min 150° (according to die if exist)	Check and record every 2~4 thousand times
8	Slump	Free faller movement for each side、cording、 angle (75cm High、 6 sides、 2 angle、 2 cording)	End

10 Inspection standard

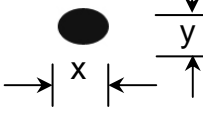
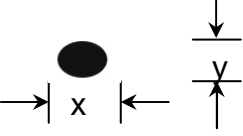
No	Item	Criterion									
01	Outline Dimension	In accord with drawing									
02	Position-finding Dimension Assemble Dimension	In accord with drawing									
03	LCD black spots, white spots (Round type)	Round type: non display 3.1 Small area LCD Unit : mm  <table border="1" data-bbox="778 750 1300 1064"> <thead> <tr> <th>Dimension</th> <th>Qualified Quantity</th> </tr> </thead> <tbody> <tr> <td>$D \leq 0.1$</td> <td>Ignore</td> </tr> <tr> <td>$0.1 < D \leq 0.15$</td> <td>2</td> </tr> <tr> <td>$D > 0.15$</td> <td>0</td> </tr> </tbody> </table>	Dimension	Qualified Quantity	$D \leq 0.1$	Ignore	$0.1 < D \leq 0.15$	2	$D > 0.15$	0	
		Dimension	Qualified Quantity								
$D \leq 0.1$	Ignore										
$0.1 < D \leq 0.15$	2										
$D > 0.15$	0										
3.2 Large area LCD  <table border="1" data-bbox="769 1243 1300 1630"> <thead> <tr> <th>Dimension</th> <th>Qualified Quantity</th> </tr> </thead> <tbody> <tr> <td>$D \leq 0.1$</td> <td>Ignore</td> </tr> <tr> <td>$0.1 < D \leq 0.15$</td> <td>2</td> </tr> <tr> <td>$0.15 < D \leq 0.20$</td> <td>1</td> </tr> <tr> <td>$D > 0.20$</td> <td>0</td> </tr> </tbody> </table> <p>C-STN : if $D > 0.1$, unqualified</p>	Dimension	Qualified Quantity	$D \leq 0.1$	Ignore	$0.1 < D \leq 0.15$	2	$0.15 < D \leq 0.20$	1	$D > 0.20$	0	
Dimension	Qualified Quantity										
$D \leq 0.1$	Ignore										
$0.1 < D \leq 0.15$	2										
$0.15 < D \leq 0.20$	1										
$D > 0.20$	0										

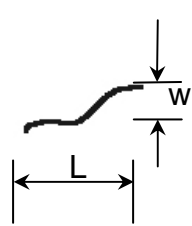
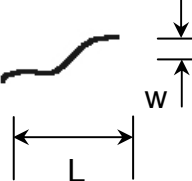
04	LCD black spots, white spots (Line Style)	<p>Unit : mm</p> 		4.1 Small area LCD														
		<table border="1"> <thead> <tr> <th>Length</th> <th>Width</th> <th>Qualified Quantity</th> </tr> </thead> <tbody> <tr> <td>-</td> <td>≤ 0.015</td> <td>Ignore</td> </tr> <tr> <td>≤ 1.0</td> <td rowspan="2">$0.015 < W \leq 0.025$</td> <td>2</td> </tr> <tr> <td>≤ 2.0</td> <td>1</td> </tr> <tr> <td>≤ 1.0</td> <td>$0.025 < W \leq 0.05$</td> <td>1</td> </tr> <tr> <td>-</td> <td>$D > 0.05$</td> <td>According to circle</td> </tr> </tbody> </table>	Length	Width	Qualified Quantity	-	≤ 0.015	Ignore	≤ 1.0	$0.015 < W \leq 0.025$	2	≤ 2.0	1	≤ 1.0	$0.025 < W \leq 0.05$	1	-	$D > 0.05$
Length	Width	Qualified Quantity																
-	≤ 0.015	Ignore																
≤ 1.0	$0.015 < W \leq 0.025$	2																
≤ 2.0		1																
≤ 1.0	$0.025 < W \leq 0.05$	1																
-	$D > 0.05$	According to circle																
		<p>4.2 Large area LCD</p> 																
		<table border="1"> <thead> <tr> <th>Length</th> <th>Width</th> <th>Qualified Quantity</th> </tr> </thead> <tbody> <tr> <td>-</td> <td>≤ 0.015</td> <td>Ignore</td> </tr> <tr> <td>≤ 2.0</td> <td>$0.015 < W \leq 0.025$</td> <td>2</td> </tr> <tr> <td>≤ 1.0</td> <td>$0.025 < W \leq 0.05$</td> <td>1</td> </tr> <tr> <td>-</td> <td>$D > 0.05$</td> <td>According to circle</td> </tr> </tbody> </table>	Length	Width	Qualified Quantity	-	≤ 0.015	Ignore	≤ 2.0	$0.015 < W \leq 0.025$	2	≤ 1.0	$0.025 < W \leq 0.05$	1	-	$D > 0.05$	According to circle	
Length	Width	Qualified Quantity																
-	≤ 0.015	Ignore																
≤ 2.0	$0.015 < W \leq 0.025$	2																
≤ 1.0	$0.025 < W \leq 0.05$	1																
-	$D > 0.05$	According to circle																
		<p>CSTN : If $W \geq 0.015$, unqualified Ignore beyond viewing area</p>																
05	LCD Scratch , Threadlike Fiber	<p>Same to NO.3 circle sightline and surface of LCD is vertical (2) Same to NO.3 line style</p>																
06	POL	<p>It is not admissible that POL is beyond the edge of glass, else, unqualified. It is essential that POL is over the 50 percent of width of frame , else ,unqualified. According to the drawing in case of special definition.</p>																
07	IC/FPC Bonding	Scratch	Reject															

		Intensity Of Adhesion	If lower than specification, reject	
		Gold Fold Twist	Reject	
07	IC/FPC Bonding	Silicon	According to outline, no gold outside, seal can not be higher than LCD	
		FPC Gold Sever	Reject	
08	SMT	Lack of Component, Polarity Inverse	If exist, reject	
		Leak Solder, Virtual Solder	If exist, reject	
		Short Circuit In Solder Point	If exist, reject	
		Tin Ball	If exist, reject	
		Tin Acumination	If visual, reject	
		Height Solder Point	If higher 0.5mm than component. reject	
		Height of component	Either side higher 0.5mm than component, reject	

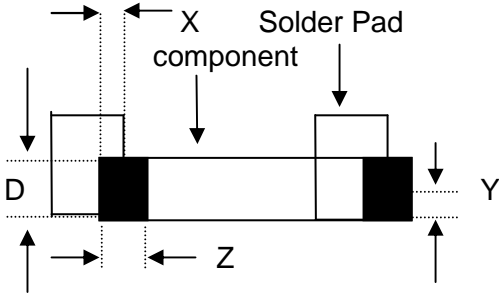
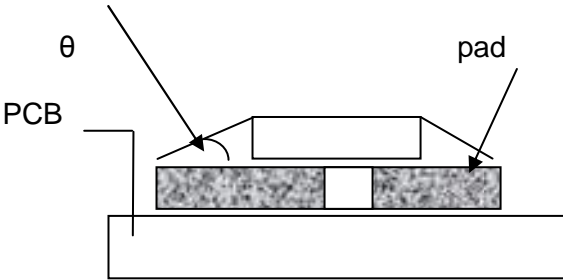
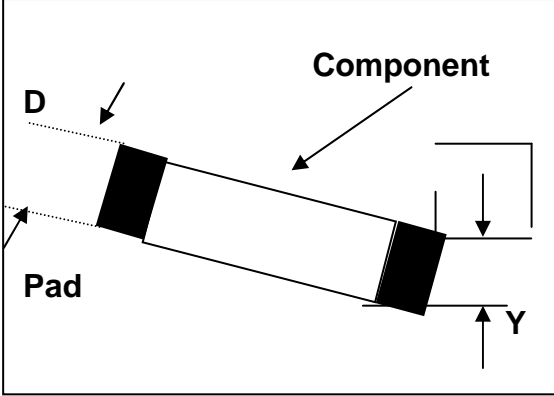
		Component Shift	 <p> $X < 3/4Z$ reject $y > 1/3D$ reject </p>
08	SMT	Few Tin	 <p>If $\theta \leq 20^\circ$ reject</p>
		Component Deflection	 <p>If $Y > 1/3D$ reject</p>
		Component Carcass Sideways	Reject

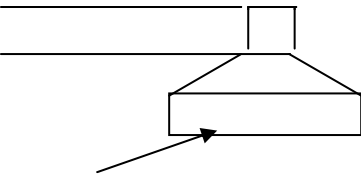
		Component Carcass Sideways	If exist with visual inspection , reject	
		Lot Tin	A: Tin accrete the solder side completely , hollowly ,Ok B: Tin accrete the solder side completely , full circle arc , ok C: Jointing include whole solder side, height of tin>50 percent of height of component, reject	
		Few Tin	A: Tin accrete the solder side completely , hollowly ,Ok B: height of tin > 1/3 of solder side of component , ok C: height of tin \leq 1/3 of solder side of component, reject	
08	SMT	<p style="text-align: center;">Normal</p>  <p style="text-align: center;">Jointing side</p>		
		Short circuit 、 Open circuit	Forbid	
09	Light	Quality of CSTN Display	1、 Rolling strake with visual inspection, forbid 2、 Differentness of color in viewing area with visual inspection (full white、 red、 green、 blue), forbid 3 、 Display change with visual inspection , forbid	

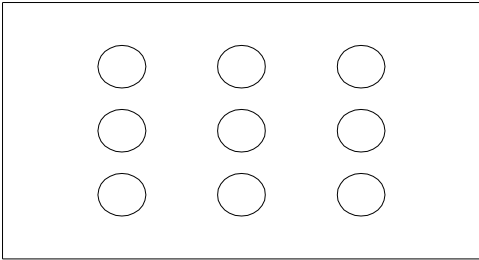
10	Color Of CIE Coordinate		x	y	Drive LCD under normal condition, 25°C $\phi=0$ $\theta=0$ Test white、red、green blue with DMS Record
		white	± 0.05	± 0.05	
		Red	± 0.05	± 0.05	
		Green	± 0.05	± 0.05	
		Blue	± 0.05	± 0.05	
		According to the specification or sample customer have approved			
11	Brightness	In accord with product specification	Drive condition is according to specification Measure location is in Follow Picture 3、 Adjust brightness instrument to zero , burrow against the surface of LCD , press “measure” , record when the display is steady. (YOKOGAWA-3298)		
			 <p style="text-align: center;">Measure location</p>		
12	CR (Max)	According to specification	According to product specification Measure instrument (DMS-501)		
13	Response time	According to specification	According to product specification Measure instrument (DMS-501)		
14	Viewing angle	According to specification	According to product specification Measure instrument (DMS-501)		
15	Vibration、 Ring	Compare with the sample customer supply	Compare with the sample customer supply when assemble		
16	Frequency Of FPC Bend	According to the use of product (main FPC of foldaway cell phone ≥ 6 thousand)	Measure instrument Bend angle : 150° Fix FPC in the casement when customer supply		

11 Handling Precautions

11.1 Mounting method

The LCD panel module consists of two thin glass plates with polarizers which easily be damaged. And since the module is so constructed as to be fixed by utilizing fitting holes in the printed circuit board.

Extreme care should be needed when handling the LCD modules.

11.2 Caution of LCD handling and cleaning

When cleaning the display surface, Use soft cloth with solvent [recommended below] and wipe lightly

- Isopropyl alcohol
- Ethyl alcohol

Do not wipe the display surface with dry or hard materials that will damage the polarizer surface.

Do not use the following solvent:

- Water
- Aromatics

Do not wipe ITO pad area with the dry or hard materials that will damage the ITO patterns

Do not use the following solvent on the pad or prevent it from being contaminated:

- Soldering flux
- Chlorine (Cl) , Sulfur (S)

If goods were sent without being silicon coated on the pad, ITO patterns could be damaged due to the corrosion as time goes on.

If ITO corrosion happens by miss-handling or using some materials such as Chlorine (Cl), Sulfur (S) from customer, Responsibility is on customer.

11.3 Caution against static charge

The LCD module uses C-MOS LSI drivers, so we recommend that you:

Connect any unused input terminal to V_{dd} or V_{ss}, do not input any signals before power is turned on, and ground your body, work/assembly areas, assembly equipment to protect against static electricity.

11.4 packing

- Module employs LCD elements and must be treated as such.
- Avoid intense shock and falls from a height.
- To prevent modules from degradation, do not operate or store them exposed direct to sunshine or high temperature/humidity

11.5 Caution for operation

- It is an indispensable condition to drive LCD's within the specified voltage limit since the higher voltage than the limit causes the shorter LCD life.
 - An electrochemical reaction due to direct current causes LCD's undesirable deterioration, so that the use of direct current drive should be avoided.
 - Response time will be extremely delayed at lower temperature than the operating temperature range and on the other hand at higher temperature LCD's show dark color in them. However those phenomena do not mean malfunction or out of order with LCD's, which will come back in the specified
-

operation temperature.

- If the display area is pushed hard during operation, some font will be abnormally displayed but it resumes normal condition after turning off once.
- A slight dew depositing on terminals is a cause for electro-chemical reaction resulting in terminal open circuit.

Usage under the maximum operating temperature, 50%Rh or less is required.

11.6 storage

In the case of storing for a long period of time for instance, for years for the purpose or replacement use, the following ways are recommended.

- Storage in a polyethylene bag with the opening sealed so as not to enter fresh air outside in it . And with no desiccant.
- Placing in a dark place where neither exposure to direct sunlight nor light's keeping the storage temperature range.
- Storing with no touch on polarizer surface by the anything else.

[It is recommended to store them as they have been contained in the inner container at the time of delivery from us

11.7 Safety

- It is recommendable to crash damaged or unnecessary LCD's into pieces and wash off liquid crystal by either of solvents such as acetone and ethanol, which should be burned up later.
- When any liquid leaked out of a damaged glass cell comes in contact with your hands, please wash it off well with soap and water

12 Precaution for use

12.1

A limit sample should be provided by the both parties on an occasion when the both parties agreed its necessity. Judgment by a limit sample shall take effect after the limit sample has been established and confirmed by the both parties.

12.2

On the following occasions, the handing of problem should be decided through discussion and agreement between responsible of the both parties.
