

SPECIFICATION

Customer	InterElcom	Product	TOP LED
Customer Type		Type	IE-5050WCR-SB-D
Customer No.		Version NO	B

APPROVED SIGNATURES			



Research & Development Center			Customer (Stamp)
APPROVE	CHECK	DRAW	CONFIRM
(Release Date): 2014-11-27			

IE-5050WCR-SB-D

Technical Data Sheet



This product is generally used as indicator and luminary for electronic equipment .
And it also be widely used for indoor and outdoor decorative lighting.

Features:	➤ Material: InGaN	Emitting Color: Cool White
	➤ Encapsulation: silicone	
	➤ Soldering methods: Pb-Free reflow soldering	
	➤ High Luminous Intensity ,Low Power Dissipation,good Reliability and Long Life	
	➤ Complied With ROHS Directive	

Catalogue

Electrical Characteristics.....	2
Typical Characteristic Curves.....	3
Reliability Test Items And Conditions.....	4
Outline Dimensions.....	5
Packaging.....	6
Guideline for Soldering.....	8
Precautions.....	10

*The Specifications of the product may be modified for improvement without notice.

Electrical Characteristics

◇ Absolute Maximum Ratings (Temperature=25°C):

Parameter	Symbol	Rating	Unit
Forward Current	I_F	75	mA
Pulse Forward Current *	I_{FP}	200	mA
Reverse Voltage	V_R	5	V
Operating Temperature	T_{OPR}	-30 ~ +85	°C
Storage Temperature	T_{stg}	-40 ~ +100	°C
Power Dissipation	P_D	270	mW

* Note: Pulse width ≤ 0.1 ms, Duty $\leq 1/10$

◇ Electro-Optical Characteristics (Temperature=25°C):

Parameter	Symbol	Condition	Min.	Typ.	Max.	Unit	
Reverse Current	I_R	$V_R=5V$			10	μA	
Forward Voltage	V_F	$I_F=60mA$	2.8	3.2	3.6	V	
Chromaticity Coordinates	X				0.28		
	Y				0.28		
Color Temperature	T_C				10000		K
Luminous Intensity	I_V			7.7	8.5		cd
Luminous Flux	Φ_v			17	20		lm
View Angle	$2\theta_{1/2}$				110		deg.

Typical Characteristics Curves

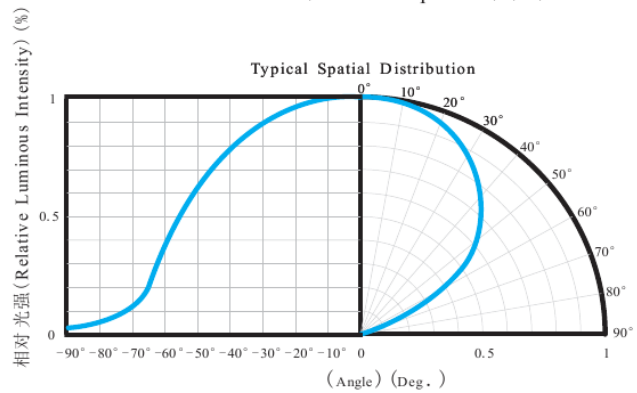
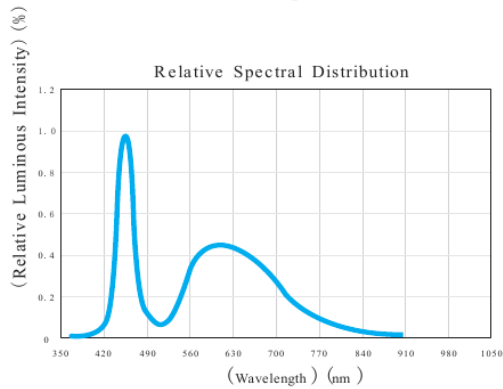
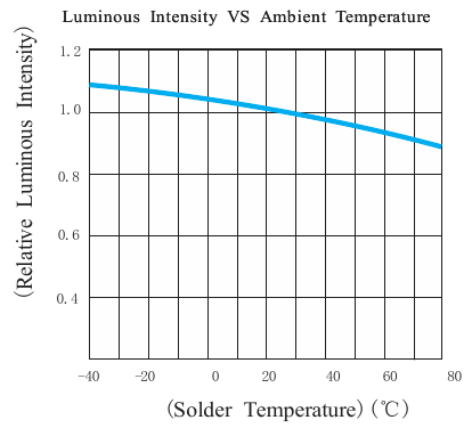
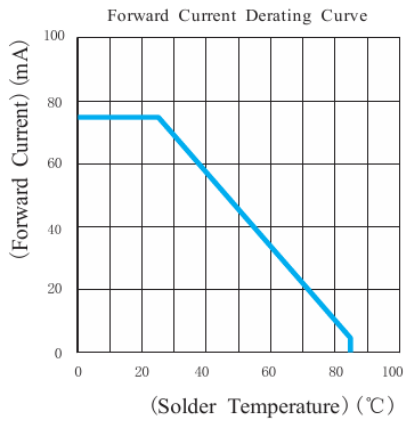
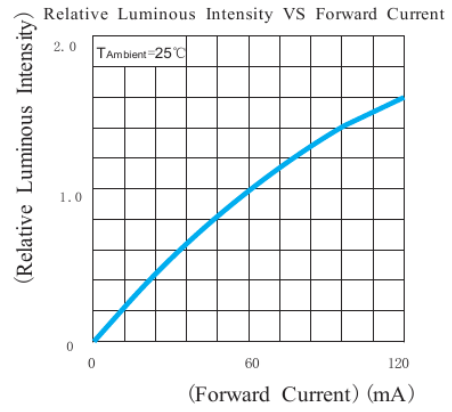
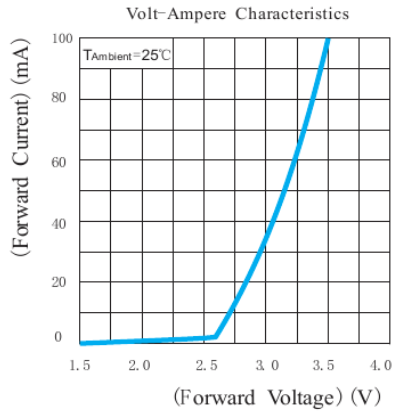

Reliability Test Items And Conditions

Test Items	Reference	Test Conditions	Time	Quantity	Criterion
Thermal Shock	MIL-STD-202G	-40°C(30min)←→100°C(30min)	100 cycles	22	0/22
Temperature And Humidity Cyclic	JEITA ED-4701 200 203	-10°C~65°C , 0%~90%RH 24hrs./1cycle	10 cycles	22	0/22
High Temperature Storage	JEITA ED-4701 200 201	Ta=100°C	1000h	22	0/22
Low Temperature Storage	JEITA ED-4701 200 202	Ta=-40°C	1000h	22	0/22
High Temperature High Humidity Storage	JEITA ED-4701 100 103	Ta=60°C , RH=90%	1000h	22	0/22
High Temperature Life Test	JESD22-A108D	Ta=80°C IF =60mA	1000h	22	0/22
Life Test	JESD22-A108D	Ta=25°C IF =60mA	1000h	22	0/22
Resistance to Soldering Heat	JEITA ED-4701 300 301	Tsol*=260°C 10secs .	3 times	22	0/22

Criteria For Judging Damage

Test Items	Symbol	Test Conditions	Criteria For Judging Damage
Forward Voltage	V _F	I _F = I _{FT}	Initial Data±10%
Reverse Current	I _R	V _R = 5V	I _R ≤10μA
Luminous Intensity	I _V	I _F = I _{FT}	Average I _V degradation≤30%; Single LED I _V degradation≤50%
Resistance to Soldering Heat			Material without internal cracks, no material between stripped, no deaded light.

* Note: T_{sol}-Temperature of tin liquid.

Outline Dimension

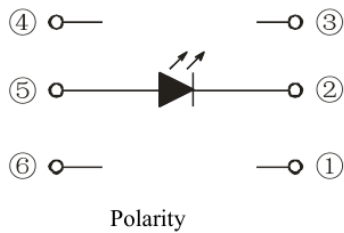
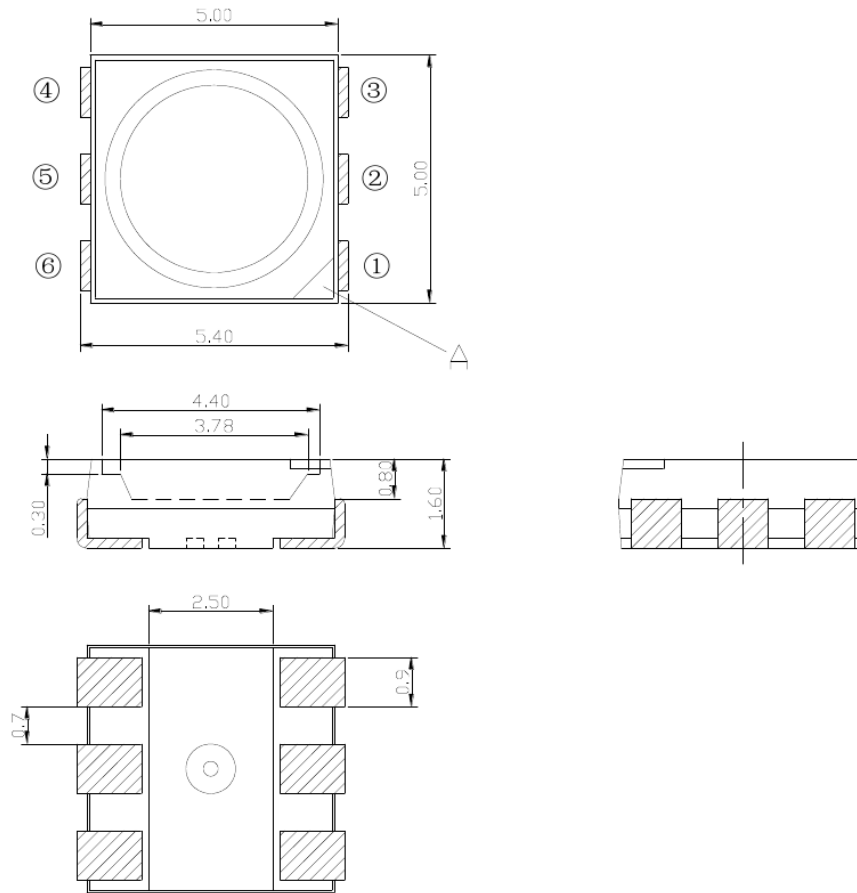

Note:

A: Nick Mark

All dimensions in mm.

Tolerances unless mentioned is ± 0.1 mm.

Packaging (1)

◇ Carrier Tape

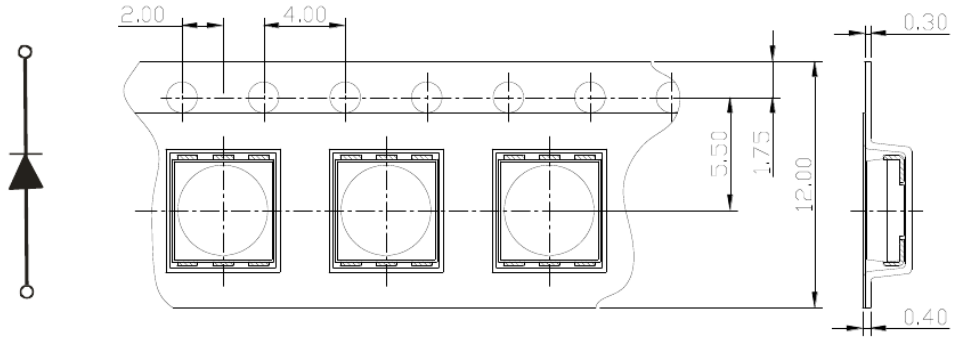

All dimensions in mm, tolerances unless mentioned is ± 0.1 mm.

◇ Details Of Carrier Tape

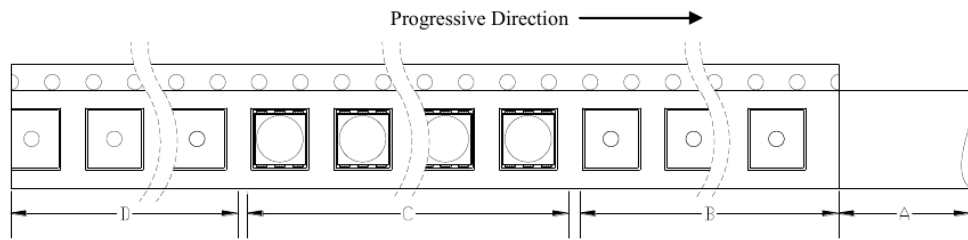

A: Top Cover Tape, 300mm; B: Leader, Empty, 200mm; C: 4000 Lamps Loaded; D: Trailer, Empty, 200mm.

◇ Reel Dimension

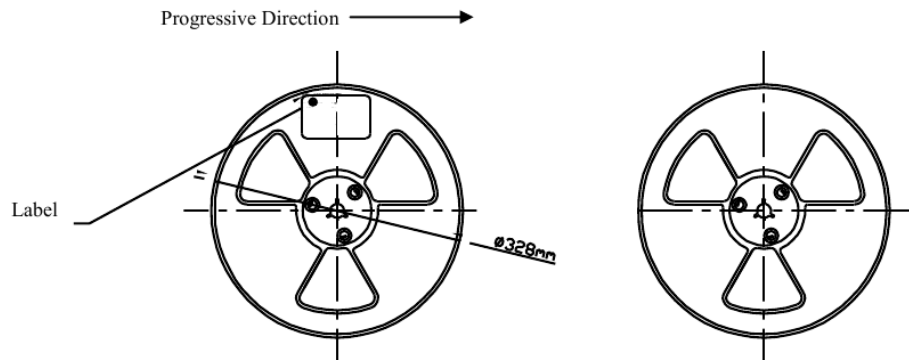

Packaging (2)

✧ Moisture Proof and Anti-Electrostatic Foil Bag

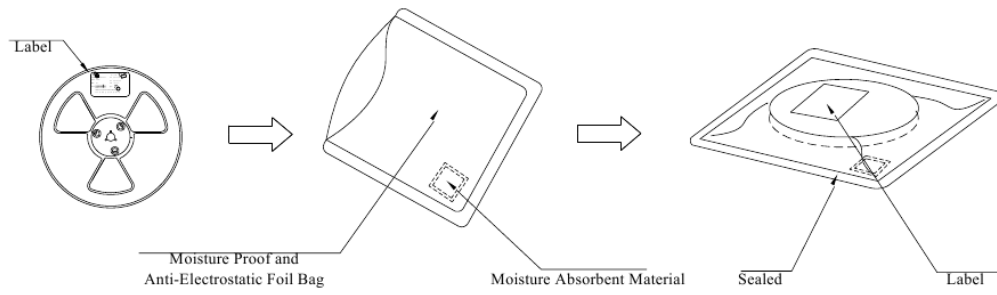

✧ Cardboard Box

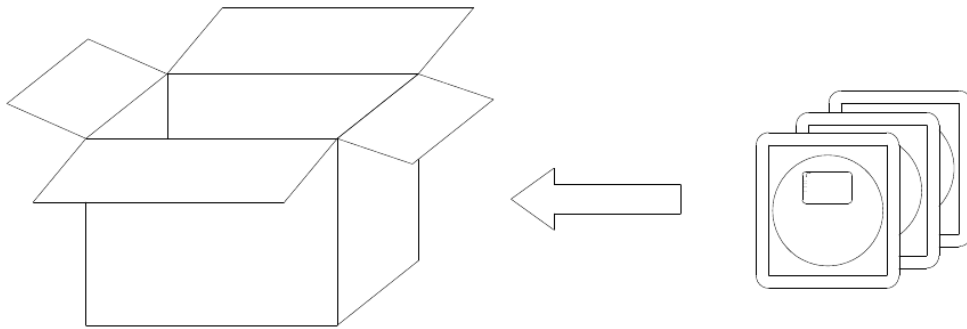

Guideline for Soldering (1)

1. Hand Soldering

A soldering iron of less than 20W is recommended to be used in Hand Soldering. Please keep the temperature of the soldering iron under 360°C while soldering. Each terminal of the LED is to go for less than 3 second and for one time only.

Be careful because the damage of the product is often started at the time of the hand soldering.

2. Reflow Soldering: Use the conditions shown in the under Figure of Pb-Free Reflow Soldering.

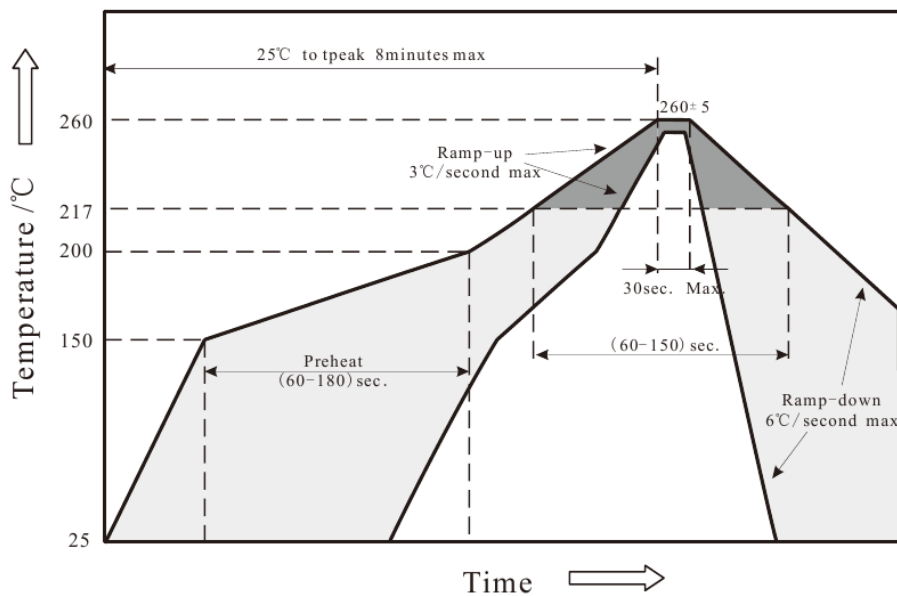

- Reflow soldering should not be done more than two times.
- Stress on the LEDs should be avoided during heating in soldering process.
- After soldering, do not deal with the product before its temperature drop down to room temperature.

Guideline for Soldering (2)

3. Cleaning

It is recommended that alcohol be used as a solvent for cleaning after soldering. Cleaning is to go under 30°C for 3 minutes or 50°C for 30 seconds. When using other solvents, it should be confirmed beforehand whether the solvents will dissolve the package and the resin or not.

Ultrasonic cleaning is also an effective way for cleaning. But the influence of Ultrasonic cleaning on LED depends on factors such as ultrasonic power. Generally, the ultrasonic power should not be higher than 300W. Before cleaning, a pre-test should be done to confirm whether any damage to LEDs will occur.

- * **Note:** This general guideline may not apply to all PCB designs and configurations of all soldering equipment. The technique in practice is influenced by many factor, it should be specialized base on the PCB designs and configurations of the soldering equipment.



Precautions (1)

1. Storage

- Moisture proof and anti-electrostatic package with moisture absorbent material is used, to keep moisture to a minimum.
- Before opening the package, the product should be kept at 30°C or less and humidity less than 60% RH, and be used within a year.
- After opening the package, the product should be stored at 30°C or less and humidity less than 10%RH, and be soldered within 24 hours (1 day). It is recommended that the product be operated at the workshop condition of 30°C or less and humidity less than 60%RH.
- If the moisture absorbent material has fade away or the LEDs have exceeded the storage time, baking treatment should be performed based on the following condition: $(80 \pm 5)^{\circ}\text{C}$ for 24 hours.

2. Static Electricity

Static electricity or surge voltage damages the LEDs. Damaged LEDs will show some unusual characteristic such as the forward voltage becomes lower, or the LEDs do not light at the low current. even not light.

All devices, equipment and machinery must be properly grounded. At the same time, it is recommended that wrist bands or anti-electrostatic gloves, anti-electrostatic containers be used when dealing with the LEDs.

Precautions (2)

3. Vulcanization

LED curing is due to sulfur being in bracket and the +1 price of silver in the chemical reaction generated Ag₂S in the process. It will lead to the capacity of reflecting of silver layer reducing , light color temperature drift and serious decline ,seriously affecting the performance of the product.So we should take corresponding measures to avioding vulcanization, such as to avoid using sulphur volatile substances and keeping away from high sulphur content of the material.

4. Safety Advice For Human Eyes

Viewing direct to the light emitting center of the LEDs, especially those of great Luminous Intensity will cause great hazard to human eyes. Please be careful.

5. Design Consideration

In designing a circuit, the current through each LED must not exceed the absolute maximum rating specified for each LED. In the meanwhile, resistors for protection should be applied, otherwise slight voltage shift will cause big current change, burn out may happen.

It is recommended to use Circuit A which regulates the current flowing through each LED rather than Circuit B. When driving LEDs with a constant voltage in Circuit B, the current through the LEDs may vary due to the variation in Forward Voltage (V_F) of the LEDs. In the worst case, some LED may be subjected to stresses in excess of the Absolute Maximum Rating.



Precautions (3)

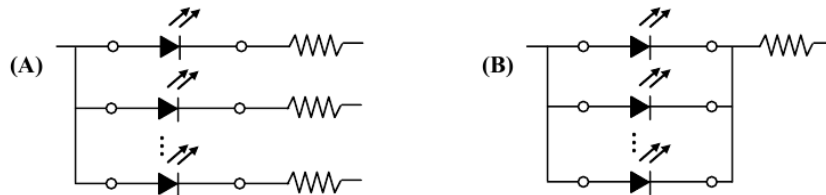

Thermal Design is paramount importance because heat generation may result in the Characteristics decline, such as brightness decreased, Color changed and so on. Please consider the heat generation of the LEDs when making the system design.

6. Others

When handling the product, touching the encapsulant with bare hands will not only contaminate its surface, but also affect on its optical characteristic. Excessive force to the encapsulant might result in catastrophic failure of the LEDs due to die breakage or wire deformation. For this reason, please do not put excessive stress on LEDs, especially when the LEDs are heated such as during Reflow Soldering.

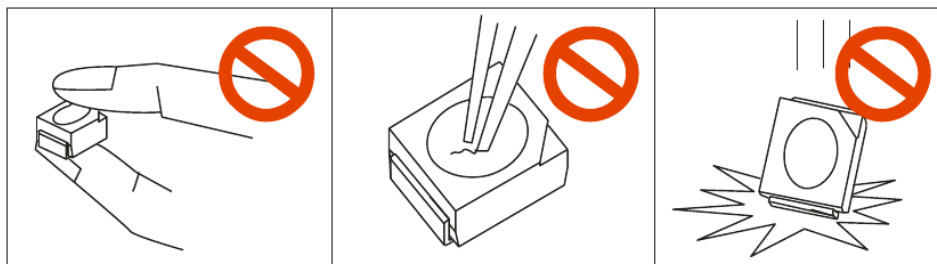

The epoxy resin of encapsulant is fragile, so please avoid scratch or friction over the epoxy resin surface. While handling the product with tweezers, do not hold by the epoxy resin, be careful.

Appendix: Chromaticity Diagram

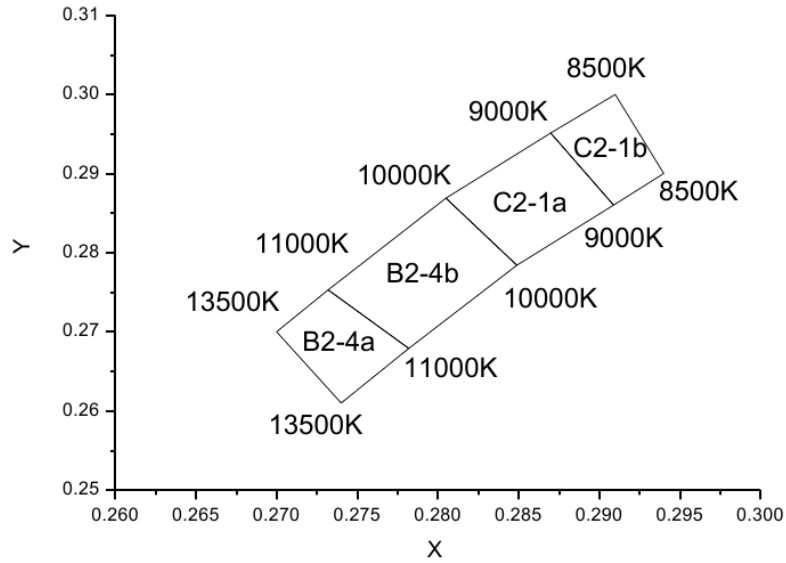

		Bottom	Left	Top	Right			Bottom	Left	Top	Right
B2-4a	x	0.274	0.27	0.2732	0.2782	B2-4b	x	0.2782	0.2732	0.2805	0.2849
	y	0.261	0.27	0.2753	0.2679		y	0.2679	0.2753	0.2869	0.2784
C2-1a	x	0.2849	0.2805	0.287	0.2909	C2-1b	x	0.2909	0.287	0.291	0.294
	y	0.2784	0.2869	0.2951	0.286		y	0.286	0.2951	0.3	0.29

Notes: *Measurement Uncertainty : ± 0.01