

Specification for approval

CUSTOMER NAME: _____

DIRECTOR: _____ TITLE: _____

PART NUMBER: **IE-3215W-SB-C-09**

REVISION: **2.0**

ISSUE DATE: **2016/11/16** RETURN DATE: / /

We are please in sending you herewith our specification and drawings for your approval.
Please return to us one copy "For Approval" with your approved signatures.

CUSTOMER'S PROPOSAL

- AGREE
- DISAGREE

REASON: _____

CUSTOMER SIGNATURE: _____

Features

- ✘ 1.6mm SMT LED, 0.90mm THICKNESS.
- ✘ LOW POWER CONSUMPTION.
- ✘ WIDE VIEWING ANGLE.
- ✘ IDEAL FOR BACKLIGHT AND INDICATOR.
- ✘ VARIOUS COLORS AND LENS TYPES AVAILABLE.
- ✘ PACKAGE: 3000PCS / REEL.
- ✘ RoHS COMPLIANT.

Description

The Yellow source color devices are made with Gallium Arsenide Phosphide on Gallium Phosphide Yellow Light Emitting Diode.

Package Dimensions

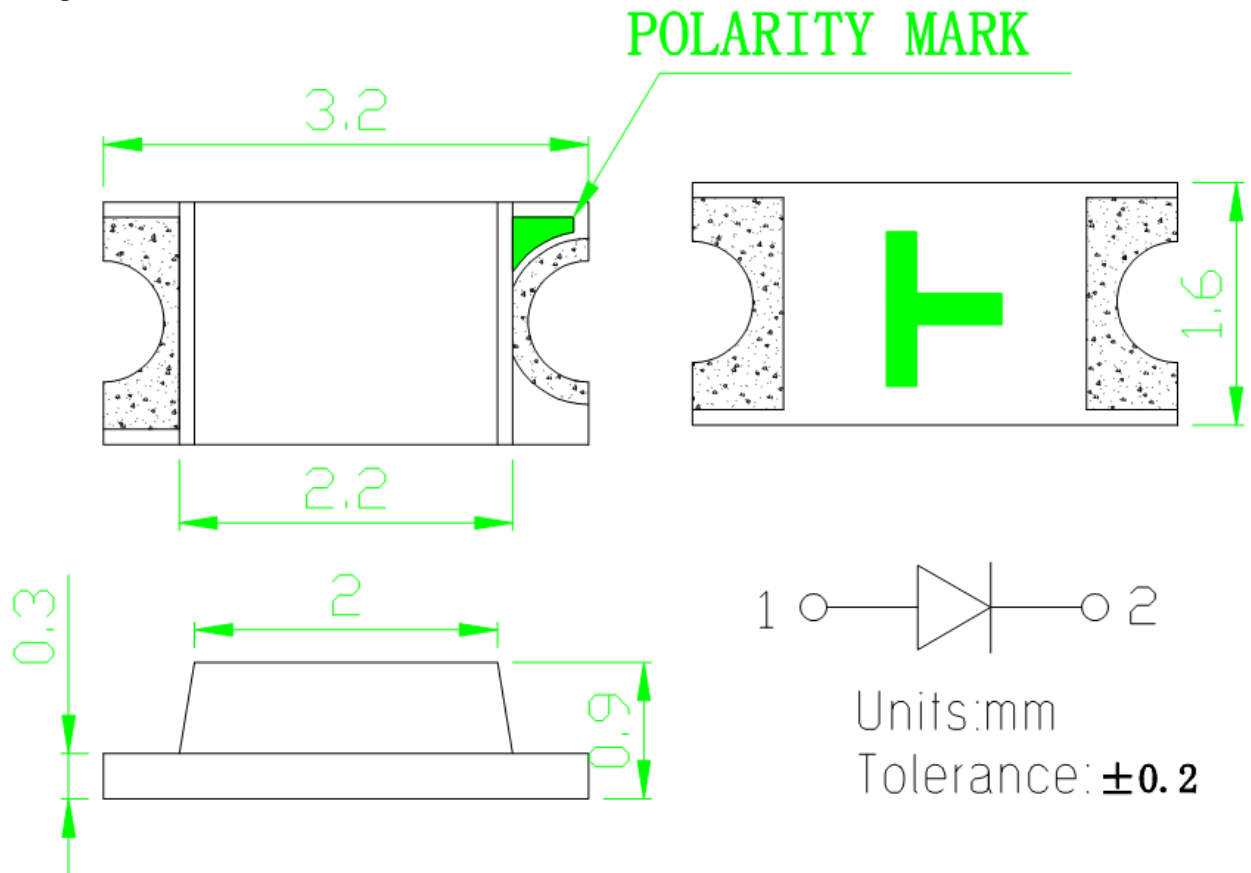

Notes:

1. All dimensions are in millimeters (inches).
2. Tolerance is ± 0.1 (0.004") unless otherwise noted.
3. Specifications are subject to change without notice.

Selection Guide

Part No.	Dice	Lens Type	Iv (mcd) @20mA		Viewing Angle
			Min.	MAX.	2 θ 1/2
IE-3215W-SB-C-09	BLUE (GaN)	Yellow Diffused	400	600	120

Note:

1. θ1/2 is the angle from optical centerline where the luminous intensity is 1/2 the optical centerline value.

Electrical / Optical Characteristics at TA=25°C

Symbol	Parameter	Device	Typ.	Max.	Units	Test Conditions
λ _{peak}	Peak Wavelength	white	8300K	12500K	nm IF=20 mA	
λ _D	Dominant Wavelength	white			nm	IF=20mA
Δλ _{1/2}	Spectral Line Half-width	white			nm	IF=20mA
C	Capacitance	white			pF	VF=0V;f=1MHz
VF	Forward Voltage	white	2.9	3.3	V	IF=20mA
IR	Reverse Current	white		2	uA	VR = 7V

Remarks:

If special sorting is required (e.g. binning based on forward voltage, luminous intensity, or wavelength), the typical accuracy of the sorting process is as follows:

1. Wavelength: +/-1nm
2. Luminous Intensity: +/-15%
3. Forward Voltage: +/-0.1V

Note: Accuracy may depend on the sorting parameters

Absolute Maximum Ratings at TA=25°C

Parameter	white	Units
Power dissipation	135	mW
DC Forward Current	25	mA
Peak Forward Current [1]	140	mA
Reverse Voltage	5	V
Operating/Storage Temperature	-40°C To +85°C	

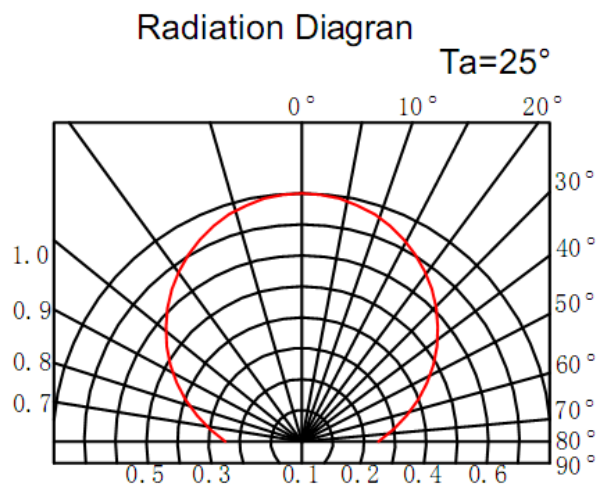
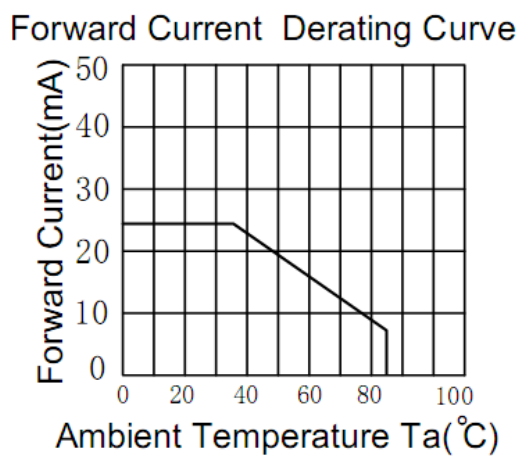
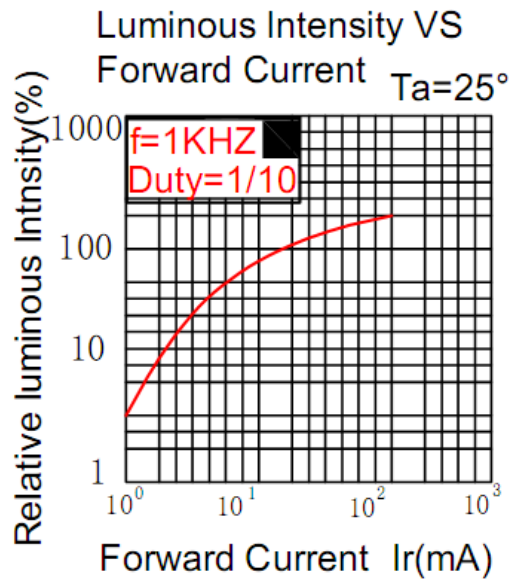
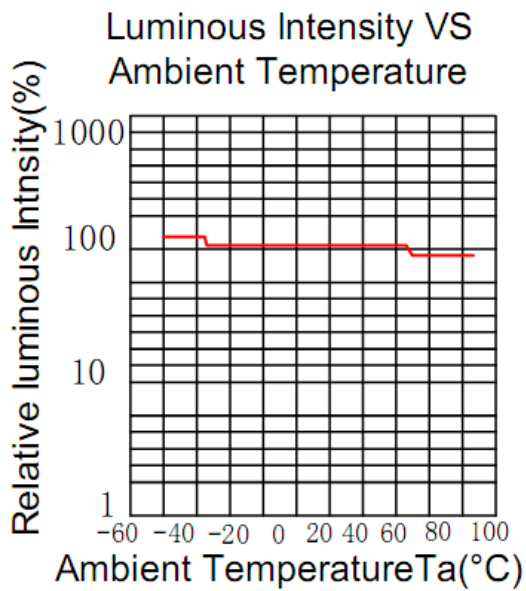
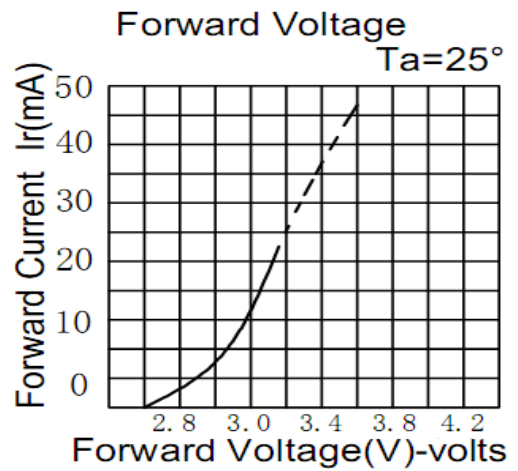
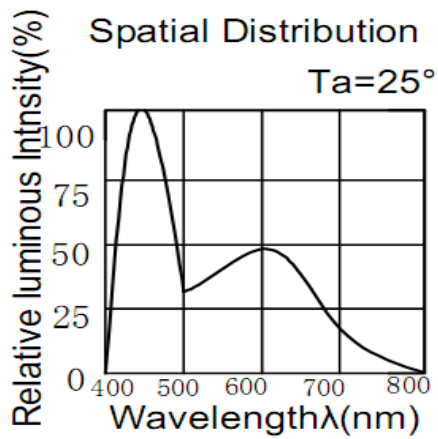

RELIABILITY

Test Items and Results

1		JEITA ED-4701	-40°C ~ 25°C ~ 100°C ~ 25°C 30 5 30 5	100	50	0/50
2		MIL-STD-202G	-40°C ~ 100°C 15 15	500	50	0/50
3		JEITA ED-4701 200 201	T _a =100°C	1000	50	0/50
4		JEITA ED-4701 200 201	T _a =-40°C	1000	50	0/50
5			T _a =25±5°C	1000	50	0/50
			I _F =20mA			
6			T _a =60°C RH=85%	1000	50	0/50
		I _F =20mA				
7		JEITA ED-4701 300 303	T _{sol} =235°C±5°C,5	5	10	0/10
8		JEITA ED-4701 300 301	T _{sol} =260°C,10 35°C 95%RH 96	10	10	0/10

5. Cautions

(1) Soldering Conditions

Number of reflow process shall be less than 2 times and cooling process to normal temperature is required between first and Second soldering process.

(Recommended soldering conditions)

回流焊接 Reflow Soldering		手工焊接
预热温度 Pre-heat temperature	有铅 Lead Solder	温度 Temperature
预热时间 Pre-heat time	140 ~ 160° C	焊接时间 Soldering time
峰值温度 Peak temperature	120 sec. Max.	350° C Max.
焊接时间 Soldering time	230° C Max.	3 sec. Max.
条件 Condition	10 sec. Max.	(one time only)
	参考下图	
	无铅 Lead-free Solder	
	180 ~ 200° C	
	120 sec. Max.	
	240° C Max.	
	10 sec. Max.	
	参考下图	

(Lead Solder)

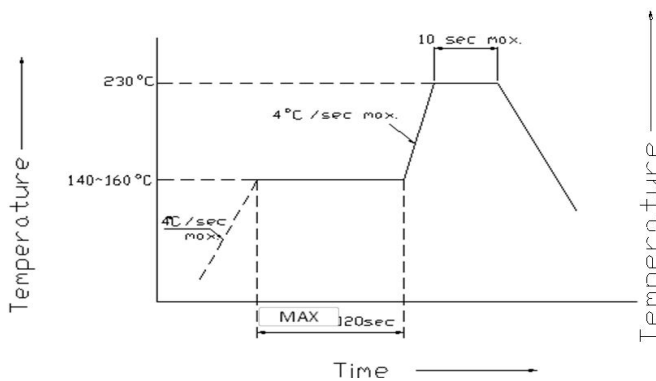

(Lead-Free Solder)

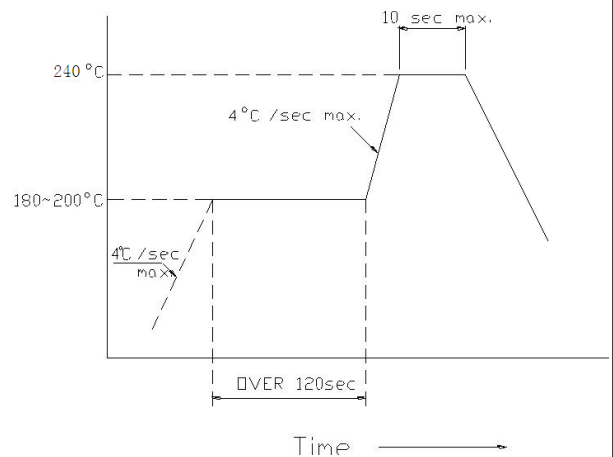

Recommended Soldering Pattern

(Units : mm)

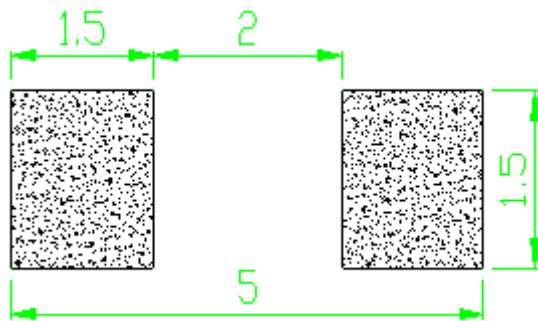

(2) Static Electricity

It is recommended that a wrist band or an anti-electrostatic glove be used when handling the LEDs.

All devices, equipment and machinery must be properly grounded.

2.0V Damaged LEDs will show some unusual characteristics such as the forward voltage becomes lower, or the LEDs do not light at the low current. Criteria : ($V_F > 2.0V$ at $I_F=0.5mA$)

(3) Moisture Proof Package

It is recommended that moisture proof package be used .

(4)

Cautions:

4.1.

Please check if there is air leak before opening the package, if so, please return the goods back to take drying process for later using.

4.2

Products can be used within 15days after packaging, after that, they must be:

4.2.1

Soldered within 24 hrs

4.2.2

Used in the condition: 30°C within and 60%RH below

4.2.3

Stored in 30%RH for moisture below.

4.3.

Products cannot be used for and over 15days after being packaged unless opening the package and take drying our process in 85°C/6H.

4.4.

Products not be used for or over 60days after being packaged please return back to take drying out and packaging process for forward using.

4.5.

Products not be used after opening the package need to be dried out for 85°C/6H

PACKAGING

The LEDs are packed in cardboard boxes after taping.

包装方式:

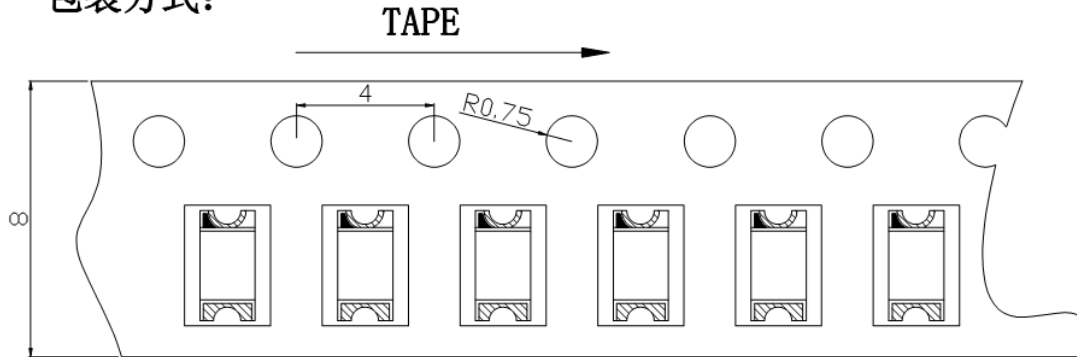

Package: 3000 pcs/reel

Reel Dimensions

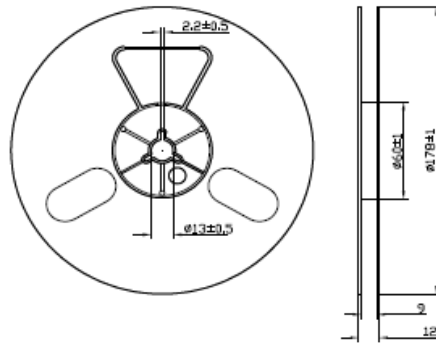

Moisture Resistant Packaging

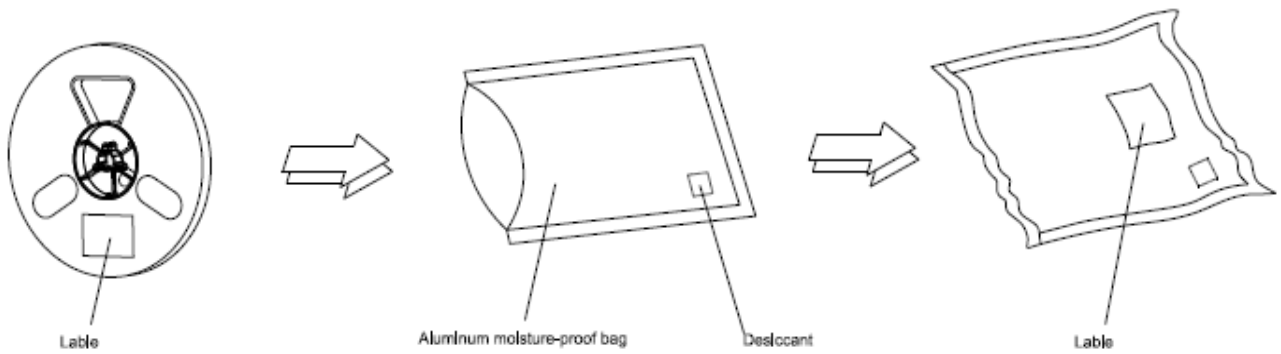

Note: The tolerances unless mentioned is ± 0.1 mm, Unit: mm