

NEW PRODUCT APPROVED

(CUSTOMERS) _____

(CUSTOMER P/N) IE-136B-C11-BW

(DESCRIPTION) 0.36"

(SAMPLE DATE) _____

Specification <input checked="" type="checkbox"/>	INSPECTION <input type="checkbox"/>	SAMPLE <input type="checkbox"/>	OTHERS <input type="checkbox"/>
(APPROVED BY)	(CHECKED BY)	(PREPARED BY)	
(COSTOMER VERDICT)			
(OK) <input type="checkbox"/>		(NG) <input type="checkbox"/>	
(APPROVED BY):		(APPROVED DATE):	
(IMPROVED ADVICE):			

REMARK: FOR OFFERING THE BEST SERVICE TO CUSTOMER, PLEASE FAX THE DATA TO FACTORY IN TIME

1. FEATURES:

- High intensity and reliability
- High quality, Low power requirement and low cost
- IC compatible , Easy assembly

2. DESCRIPTION:

- 0.36 inch (9.1mm) height, Single digit display
- Black face, White segment, Blue display
- Common Cathode, static drive connect
- Dice material: **InGaN** Blue

3. ABSOLUTE MAXIMUM RATINGS AT $T_a=25^\circ\text{C}$

(PARAMETER)	Max.	UNIT
Power Dissipation Per Segment	76	mW
Peak Forward Current Per Segment (1/10duty cycle 0.1ms pulse width)	100	mA
Average Forward Current Per Segment	20	mA
Derating Linear From 25°C Per Segment	0.25	mA/°C
Reverse Voltage Per Segment	5	V
Operating Temperature Range	-35°C to + 85°C	
Storage Temperature Range	-40°C to + 85°C	
Lead Soldering Temperature 260°C at 1.6mm From Body for 3 seconds		

4. ELECTRICAL/OPTICAL CHARACTERISTICS AT $T_a=25^\circ\text{C}$:

PARAMETER	SYMBOL	MIN.	TYP.	MAX.	UNIT	Test condition
Luminous Intensity Per Segment	I_v	—	15	—	mcd	$I_F=10\text{mA}$
Dominant Wavelength	λ_D	—	464	—	nm	$I_F=20\text{mA}$
Spectral Line Half-Width	$\Delta\lambda$	—	30	—	nm	$I_F=20\text{mA}$
Forward Voltage Per Segment	V_F	—	3.0	3.8	V	$I_F=20\text{mA}$
Reverse Current Per Segment	I_R	—	—	100	μA	$V_R=5\text{V}$
Luminous Intensity Matching Ratio (Segment To Segment)	I_{v-m}			2:1		$I_F=10\text{mA}$

5. Outer Dimension:

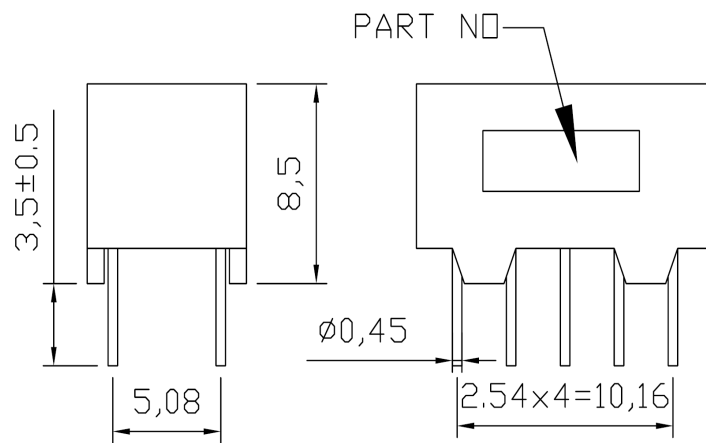
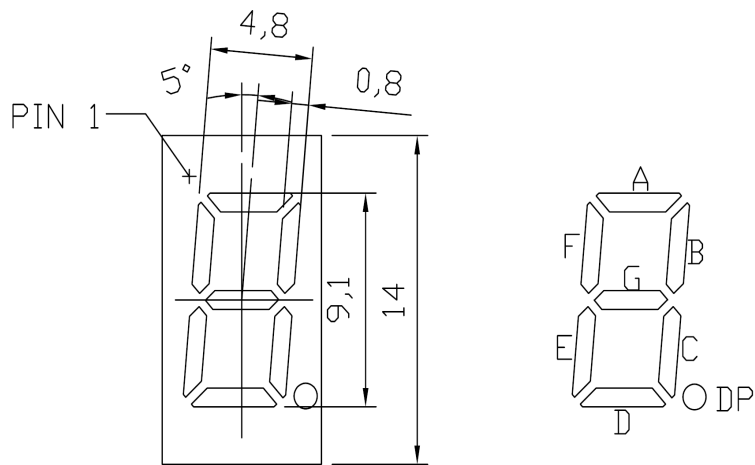

NOTES: All dimensions are in millimeters (inches) tolerance are $\pm 0.25\text{mm}(0.010)$ unless otherwise noted

6. INTERNAL CIRCUIT DIAGRAM:

