

## PRODUCT SPECIFICATIONS

MODULE NO. : IE-TFT-0282432-RTP-12

DRAWING BY : OSC

DATE : 2012-12-23

APPROVED BY : \_\_\_\_\_

REVISION : V1.0

### FOR CUSTOMER'S APPROVAL

CHECK BY : \_\_\_\_\_

DATE : \_\_\_\_\_

APPROVED BY : \_\_\_\_\_

DATE : \_\_\_\_\_

OK

NG

COMMENT:



## CONTENTS

<b>NO.</b>	<b>ITEM</b>	<b>PAGE</b>
-	Cover	1
-	History of Versions and Modifications	2
-	contents	3
1	General Specifications	4
2	Outline Drawing	5
3	Absolute Maximum Ratings	6
4	Electrical Specifications and Interface Signal	7
5	Optical Characteristics	11
6	Reliability test	12
7	Reference information	13
8	Precautions for Use of LCD Modules	15

**1.General Specifications**

Item	Main LCD	Unit	Note
LCD Type	2.8" TFT LCD	-	
Display color	262K		1
LCD Duty	1/320	-	
LCD Bias	-	-	
Viewing Direction	12:00	O'Clock	
Viewing Area(W×H)	-	mm	
Active Area(W×H)	43.20X57.60	mm	
Number of Dots	240(R,G,B)×320	mm	
Dot Size(W×H)	-	mm	
Dot Pitch(W×H)		mm	
Controller	ILI9341V	-	
V <sub>DD</sub>	2.7~3.3V	V	
Outline Dimensions	Refer to outline drawing on next page		
Backlight	LED(white)	-	
Operating Temperature	-20~+70℃	-	
Storage Temperature	-30~+80℃	-	
Weight	TBD	g	2
Data Transfer	8/16 bits parallel	-	
Display Type	Transmissive type	-	

Note 1: Select by software, and color tune is slightly changed by temperature and driving voltage.

Note 2: TBD- To Be Determined.

Note 3: Requirements on Environmental Protection:RoHS

MODEL No: IE-TFT-0282432-RTP-12

2. Outline Drawing

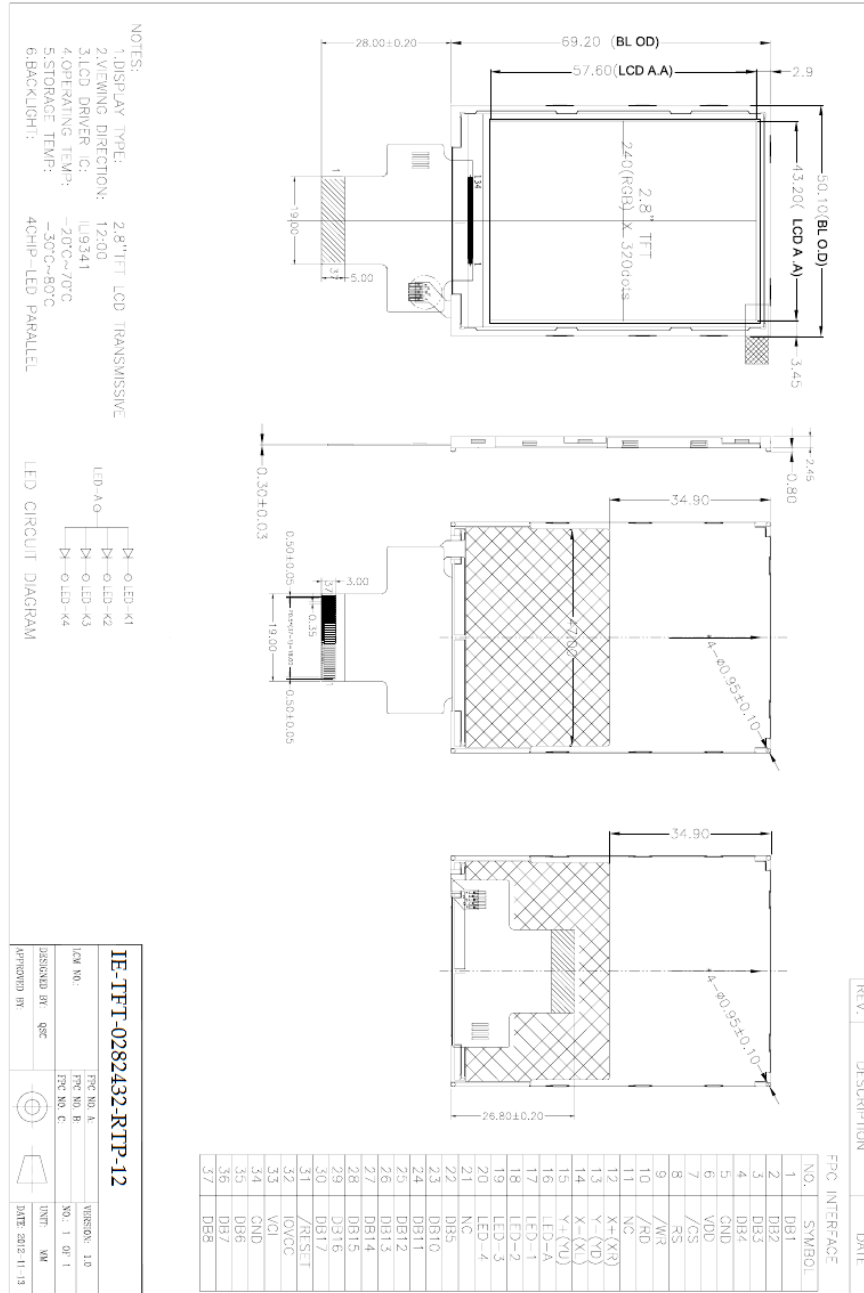

### 3. Absolute Maximum Ratings

Item	Symbol	Min.	Max.	Unit	Note
Digital Power Supply	Vcc	3	3.6	v	1,2
Analog Power Supply	Vdd	3	5.5	V	
Power Supply Voltage for Mail LCD	Vop	-	-	V	
Logic Signal Input Voltage	V <sub>i</sub>	-	-	V	
Operating Temperature	Top	-20	+70	°C	
Storage Temperature	Tst	-30	+80	°C	

1. If the module is above these absolute maximum ratings. It may become permanently damaged. Using the module within the following electrical characteristic conditions are also exceeded, the module will malfunction and cause poor reliability.

2.VDD > VSS must be maintained.

## 4. Electrical Specifications and Interface Signal

### 4.1 Electrical characteristics (Ta=25°C)

Parameter	Symbol	Condition	Min	Typ	Max	Unit	Note	
Operation voltage for Main LCM	V <sub>DD</sub>	Ta=25°C	2.4	2.8	3.3	V	1	
Input voltage	'H'	V <sub>IH</sub>	IOVCC=1.6 5~3.3V	0.8IOVCC	-	IOVCC	V	
	'L'	V <sub>IL</sub>	IOVCC=1.6 5~3.3V	-0.3	-	0.2IOVCC	V	
Output Voltage	'H'	V <sub>OH</sub>	I <sub>OH</sub> =-0.1mA	0.8IOVCC	-	-	V	
	'L'	V <sub>OL</sub>	I <sub>OL</sub> =0.1mA	-	-	0.2IOVCC	V	
Current Consumption	I <sub>CC1</sub>	Normal mode	-	85	95	mA	2	
	I <sub>CC2</sub>	Stand-by mode	-	90	100	uA	3	
	I <sub>CC3</sub>	Dimming mode	-	-	-	mA	4	

Note:

- 1: IC default setting, Duty: 1/320
- 2: Display full white. Backlight on state.
- 3: IC on standby mode.
- 4: Display full white. Backlight dimming state.

**4.2 LED backlight specification**

Item	Symbol	Condition	Min	Typ	Max	Unit	Note
Forward voltage	$V_f$	$I_f=20mA$		3.2		V	
Reverse voltage	$V_r$				4	V	
Forward current	Normal	$I_{pn}$	4-chip	-	80	mA	
	Dimming	$I_{pd}$					
Reverse Current	$I_r$	$V_r=4V$			15	$\mu A$	
Uniformity		$I_f=20mA$	80%				

**4.3 Interface Signal**

Pin No.	Symbol	I/O	Function
1	DB1	I	Data bus for low 8bits when using 16bit interface
2	DB2	I	
3	DB3	I	
4	DB4	I	
5	GND	I	Power Ground
6	VDD	I	Power supply for the I/O circuit.(2.9-3.3V)
7	/CS	I/O	Chip select input pin
8	RS	I/O	Instruction /data select input pin
9	/WR	I/O	Write execution control pin
10	/RD	I/O	Read execution control pin
11	NC	I	NC
12	X+	I/O	Touch panel X+
13	Y-	I/O	Touch panel Y-
14	X-	I/O	Touch panel X-
15	Y+	I/O	Touch panel Y+
16	LED-A	I/O	Anode for Backlight
17	LED-1	I/O	Cathode 1 for Backlight
18	LED-2	I/O	Cathode 2 for Backlight
19	LED-3	I/O	Cathode 3 for Backlight
20	LED-4	I/O	Cathode 4 for Backlight
21	DB5	I	Data bus for low 8bits when using 16bit interface
22	DB10	I	Data bus for high 8bit when using 16bit interface
23	DB11	I	
24	DB12	I	
25	DB13	I	
26	DB14	I	
27	DB15	I	
28	DB16	I	
29	DB17	I	

MODEL No: IE-TFT-0282432-RTP-12

---

30	/RESET	I/O	System reset
31	VDD	I/O	Power supply for set-up circuit.(2.9-3.3V)
32	VDD	I/O	Power supply for the I/O circuit.(2.9-3.3V)
33	GND	I/O	Power ground
34	DB6	I	Data bus for low 8bits when using 16bit interface
35	DB7	I	
36	DB8	I	

Note: Please refer to ILITEK ILI9341 data sheet for more details.

**5. Optical Characteristics**

5-1) Optical specifications(light source: C light,using CMO TN LC+Polarizer,reference only)

Ta = 25°C

Item	Symbol	Conditions	Specifications			Unit	Note	
			Min.	Typ.	Max.			
Transmittance	T%	Viewing normal angle $\theta_x = \theta_y = 0^\circ$	NA	6.3	NA	%	All left side data are based on CMO's following condition --  NTSC: 60% LC: 5091 <b>Light : C Light</b> (Machine:BM5A) Polarizer without DBEF <b>Reference Only</b>	
Contrast Ratio	CR		150	250	NA	--		
Response Time	$T_R$		NA	15	20	ms		
	$T_F$		NA	35	50	ms		
Chromaticity	Red		$X_R$	0.603	0.633	0.663		
			$Y_R$	0.296	0.326	0.356		
	Green		$X_G$	0.267	0.297	0.327		
			$Y_G$	0.547	0.577	0.607		
	Blue		$X_B$	0.103	0.133	0.163		
			$Y_B$	0.099	0.129	0.159		
White	$X_W$	0.264	0.294	0.324				
	$Y_W$	0.304	0.334	0.364				
Viewing Angle	Hor.	$\theta_{x+}$	-	45	-	deg.		
		$\theta_{x-}$	-	45	-			
	Ver.	$\theta_{y+}$	-	35	-			
		$\theta_{y-}$	-	15	-			

**Note 5-1 : The definitions of viewing angles**

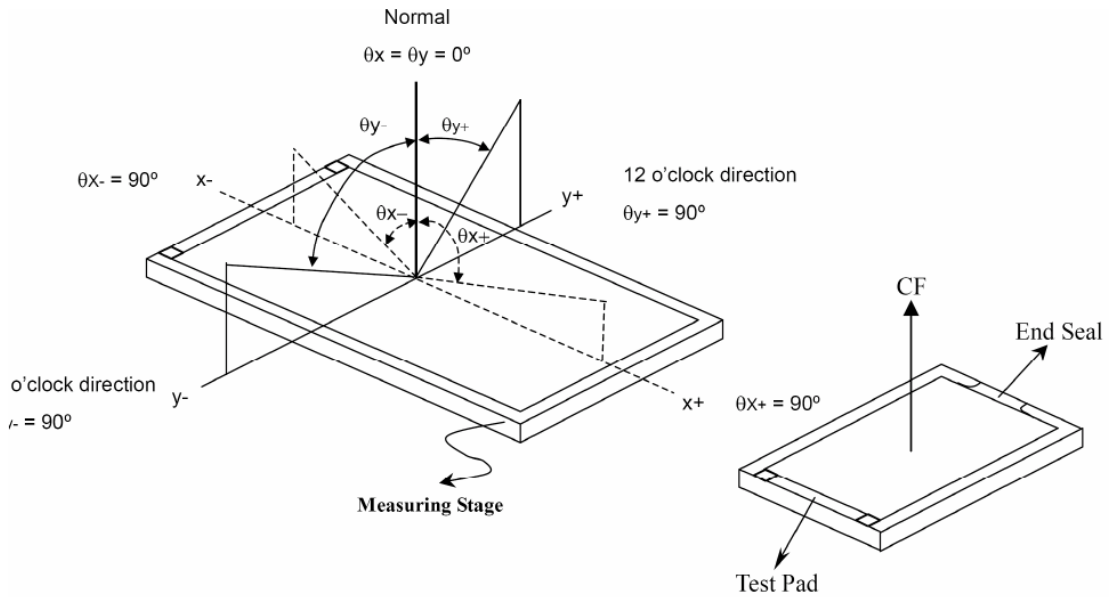

**Note 5-2 : The definition of response time :**

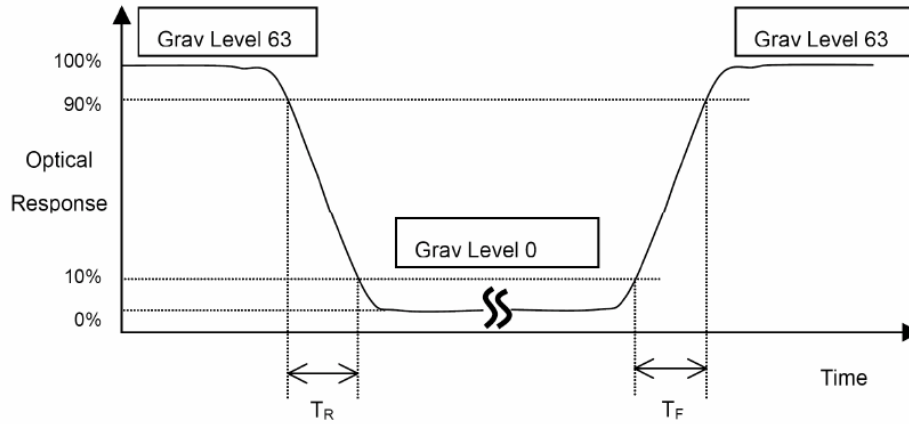

**6. Reliability test**

No	Test Item	Test Condition
1	High Temperature Operation Test	Ta = +70°C, 240 hrs
2	Low Temperature Operation Test	Ta = -20°C, 240 hrs
3	High Temperature Storage Test	Ta = +80°C, 240 hrs
4	Low Temperature Storage Test	Ta = -30°C, 240 hrs
5	High Temperature & High Humidity Operation Test	Ta = 60°C, 90%RH, 240 hrs
6	Thermal Cycling Test (non-operating)	-30°C → +80°C, 100 Cycles 60 min 60 min
7	Electrostatic Discharge Test (non-operating)	200pF, 0 Ω ±200V 1 time / each terminal

Ta: ambient temperature

[Criteria]

In the standard conditions, there is not display function NG issue occurred. (including :line defect ,no image)All the cosmetic specification is judged before the reliability stress.

## 7. Reference information

### Electrical Characteristics

Item	Symbol	Specification			Unit
		Min.	Typ	Max.	
TFT gate on voltage	VGH	-	15	-	V
TFT gate off voltage	VGL	-	-8	-	V
TFT common electrode voltage	VcomH	2.5	-	4.5	V
	VcomL	-2.0	-	0	

MODEL No: IE-TFT-0282432-RTP-12

Note 7-2:  $CR = \frac{\text{Luminance when Testing point is White}}{\text{Luminance when Testing point is Black}}$

(Testing configuration see 7-2 )

Contrast Ratio is measured in optimum common electrode voltage.

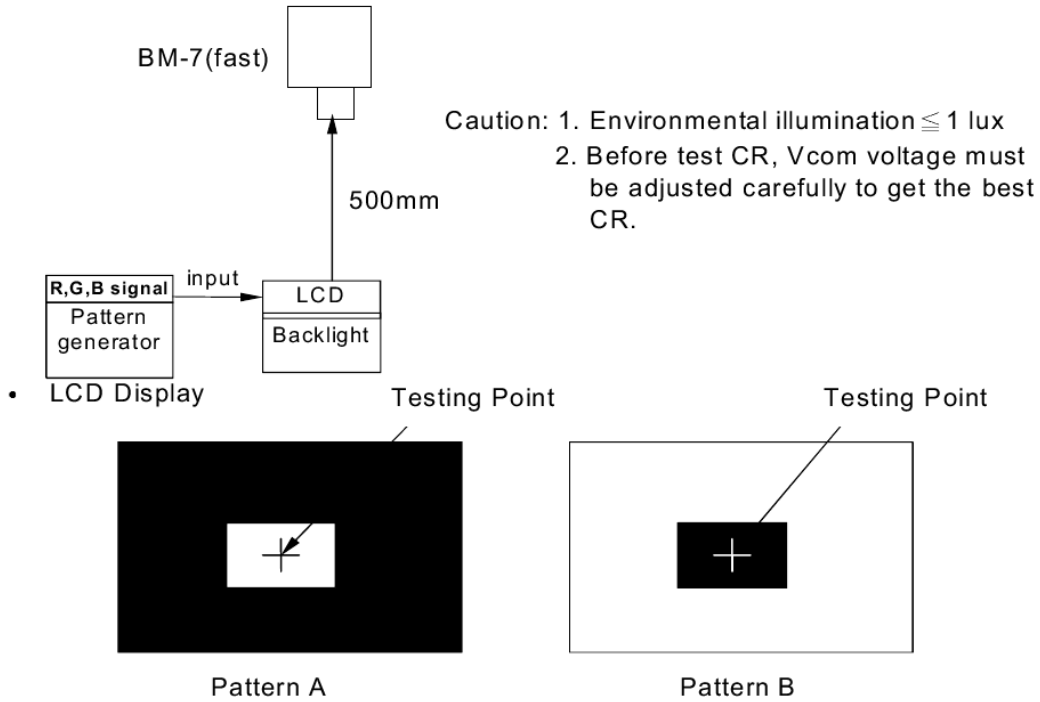

- R, G, B Waveform of Pattern A at Testing Point

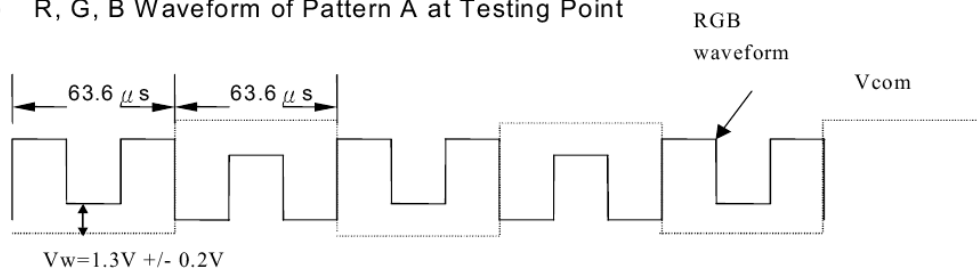

- R, G, B Waveform of Pattern B at Testing Point

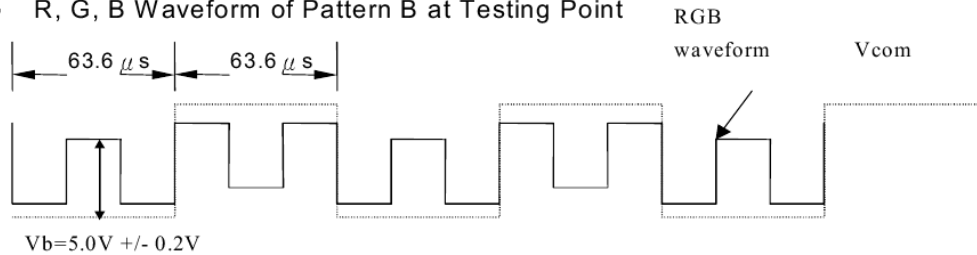

## **8. Precautions for Use of LCD Modules**

### **8.1 Handling Precautions**

- 8.1.1 The display panel is made of glass. Do not subject it to a mechanical shock by dropping it from a high place, etc.
- 8.1.2 If the display panel is damaged and the liquid crystal substance inside it leaks out, be sure not to get any in your mouth, if the substance comes into contact with your skin or clothes, promptly wash it off using soap and water.
- 8.1.3 Do not apply excessive force to the display surface or the adjoining areas since this may cause the color tone to vary.
- 8.1.4 The polarizer covering the display surface of the LCD module is and easily scratched. Handle this polarizer carefully.
- 8.1.5 If the display surface is contaminated, breathe on the surface and gently wipe it with a soft dry cloth. If still not completely clear, moisten cloth with one of the following solvents:
  - Isopropyl alcohol
  - Ethyl alcoholSolvents other than those mentioned above may damage the polarizer. Especially, do not use the following:
  - Water
  - Ketone
  - Aromatic solvents
- 8.1.6 Do not attempt to disassemble the LCD Module.
- 8.1.7 If the logic circuit power is off, do not apply the input signals.
- 8.1.8 To prevent destruction of the elements by static electricity, be careful to maintain an optimum work environment.
  - a. Be sure to ground the body when handling the LCD Modules.
  - b. Tools required for assembly, such as soldering irons, must be properly ground.
  - c. To reduce the amount of static electricity generated, do not conduct assembly and other work under dry conditions.

MODEL No: IE-TFT-0282432-RTP-12

---

- d. The LCD Module is coated with a film to protect the display surface. Be care when peeling off this protective film since static electricity may be generated.

**8.2 Storage precautions**

8.2.1 When storing the LCD modules, avoid exposure to direct sunlight or to the light of fluorescent lamps.

8.2.2 The LCD modules should be stored under the storage temperature range. If the LCD modules will be stored for a long time, the recommend condition is:

Temperature :        0°C ~ 40°C

Relatively humidity: ≤80%

8.2.3 The LCD modules should be stored in the room without acid, alkali and harmful gas.

**8.3** The LCD modules should be no falling and violent shocking during transportation, and also should avoid excessive press, water, damp and sunshine.