

# LIGHT EMITTING DIODE SPECIFICATION

CUSTOMER NAME:

DESCRIPTION: IE-3227RGB-SB-LUV-CE-03

REVISION: V2.2

ISSUE DATE: 2022 03 25

Contains trade secret information and shall not be made available to, or copied or used by anyone without written permission from the manufacturer. All rights reserved.

**Features:**

- Long operating life
- Low Power Consumption
- Anti ultraviolet Package
- Low voltage DC operated
- RoHS Compliant

**Application:**

- Backlight
- Decoration lighting
- motormeter
- Indicator

Part Number	Dice Material	Emitted Color	Lens Color
IE-3227RGB-SB-LUV-CE-03	AlGaInP InGaN InGaN	Red Green Blue	Water Clear

**Electro Optical Characteristics** ( $T_a=25^{\circ}\text{C}$ , @20mA)

Parameter	Color	Symbol	Min.	Typ.	Max.	Unit
Luminous Intensity	■	IV	600		1000	mcd
	■		2000		3500	
	■		600		1000	
Radiation Bandwidth	■	$\Delta\lambda$		20		nm
	■			35		
	■			25		
Forward Voltage	■	VF	1.90	2.00	2.40	v
	■		2.90	3.00	3.40	
	■		2.90	3.00	3.40	
Dominant Wavelength	■	$\lambda_d$	617	620	626	nm
	■		517	520	530	
	■		460	465	472	
Viewing Angle		2 $\theta$ 1/2		35		deg
Reverse Current		IR			10	$\mu\text{A}$

**Absolute Maximum Ratings** ( $T_a=25^{\circ}\text{C}$ )

Parameter	Symbol	Max.	Unit
Peak Forward Current(1/10 Duty Cycle, 0.1ms Pulse Width)	IFP	100	mA
Recommended continuous working current	IF	10	mA
Reverse Voltage	VR	5	v
Electrostatic Discharge	ESD	2000	v
Operating Temperature Range	Topr	30to+85	$^{\circ}\text{C}$
Storage Temperature Range	Tstg	40to+90	$^{\circ}\text{C}$
Reflow Soldering	Tsld	260 $^{\circ}\text{C}$ for 10secs	

### Optical & Electrical Characteristics

Relative Intensity vs.Wavelength

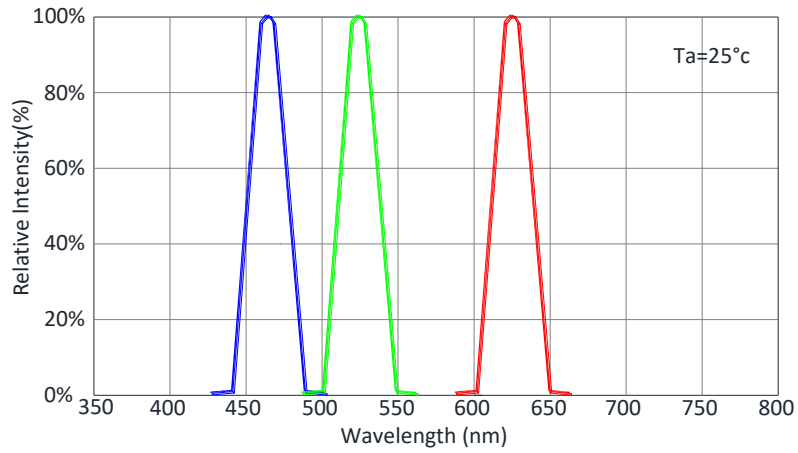

Forward Current vs.Forward Voltage

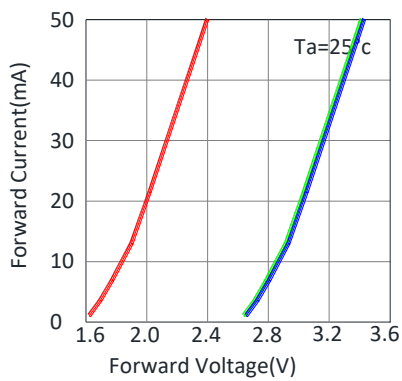

Forward Current vs.Ambient Temperature

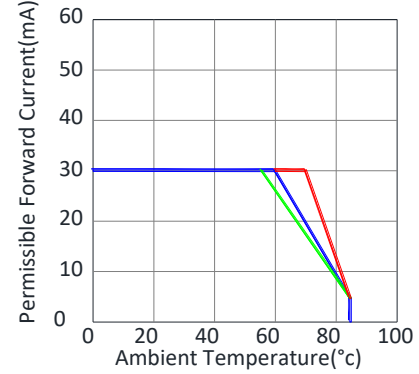

Relative Intensity vs.Forward Current

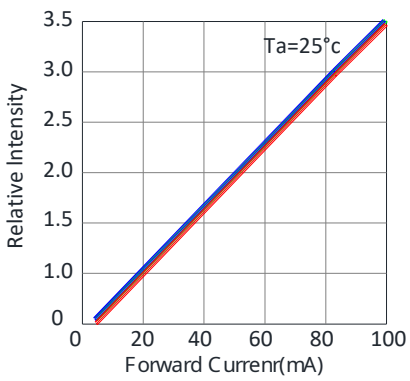

Relative Intensity vs.Ambient Temperature

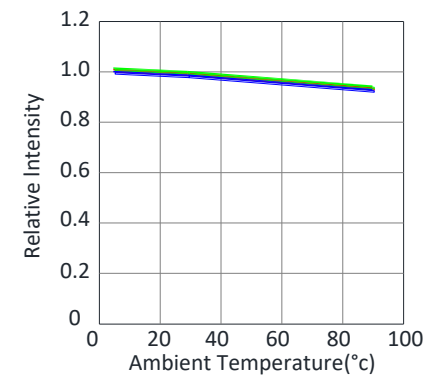

Radiation Pattern

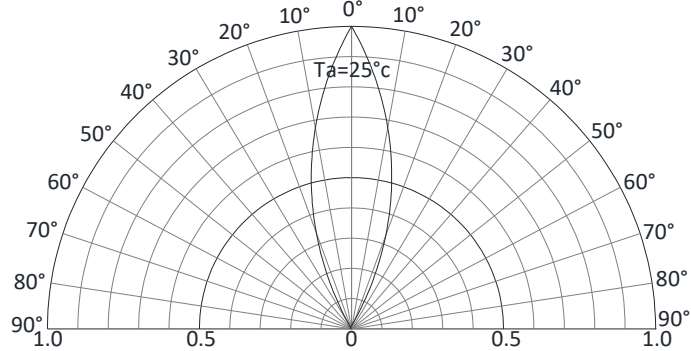

**Reliability Test Items And Conditions**

Test Items	Reference	Test Conditions	Time	Quantity	Criterion
Thermal Shock	MIL STD 202G	40°C (30min) 100°C (30min)	100 Cycles	22	0/22
Temperature And Humidity Cyclic	JEITA ED 4701 200 203	10°C~65°C; 0%~90%RH	10cycles	22	0/22
High Temperature Storage	JEITA ED 4071 200 201	Ta=100°C	1000H	22	0/22
Low Temperature Storage	JEITA ED 4071 200 202	Ta= 40°C	1000H	22	0/22
High Temperature High Humidity Storage	JEITA ED 4071 100 103	Ta=60°C; RH=90%	1000H	22	0/22
High Temperature Life Test	JESD22 A108D	Ta=80°C	1000H	22	0/22
Life Test	JESD22 A108D	Ta=25°C IF=5mA	1000H	22	0/22
Resistance to Sodering Heat	GB/T 4937, II , 2.2&2.3	Tsol*=(240±5) °C10secs	2 times	22	0/22

**Criteria For Judging Damage**

Test Items	Symbol	Test Conditions	Criteria For Judging Damage
Forward Voltage	V <sub>F</sub>	I <sub>F</sub> =I <sub>FT</sub>	Initial Data±10%
Recerse Current	I <sub>R</sub>	V <sub>R</sub> =5V	I <sub>R</sub> ≤10uA
Luminous Intensity	I <sub>V</sub>	I <sub>F</sub> =I <sub>FT</sub>	Average I <sub>V</sub> degradation≤30% ; Single LED I <sub>V</sub> degradation≤50%
Resistance to Soldering Heat			Meterial without internal cracks,no meterial between stripped,no deaded light

**Product size (Unit:mm)**

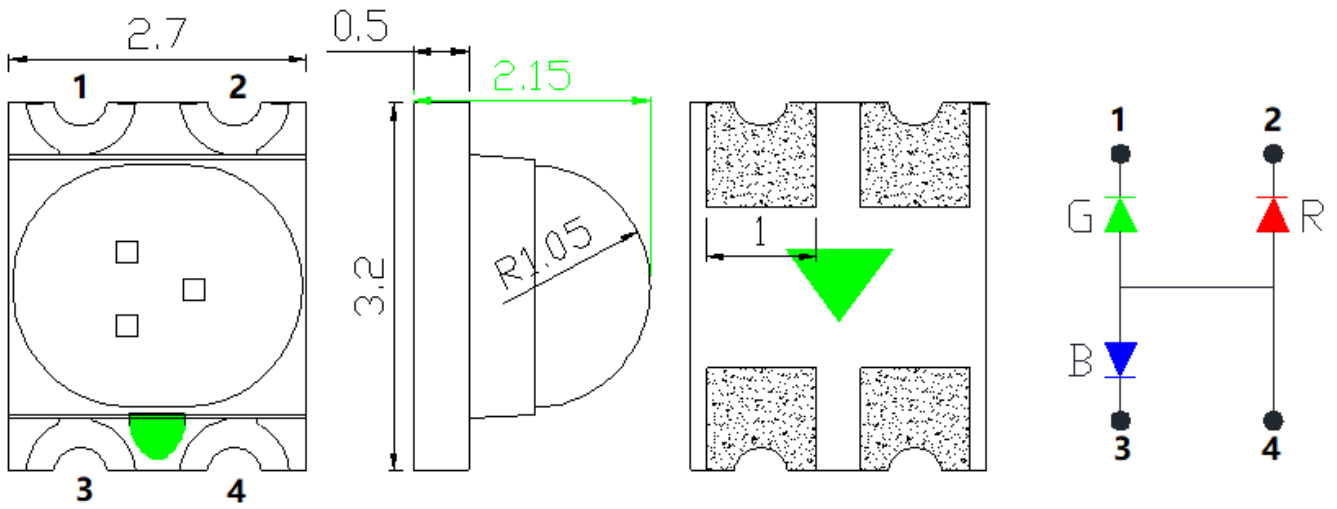

**NOTES :**

1. All dimensions are in millimeters (inches)
2. Tolerances are  $\pm 0.2\text{mm}$  (0.008inch) unless otherwise noted

**Recommended Soldering Pad Design (Unit:mm)**

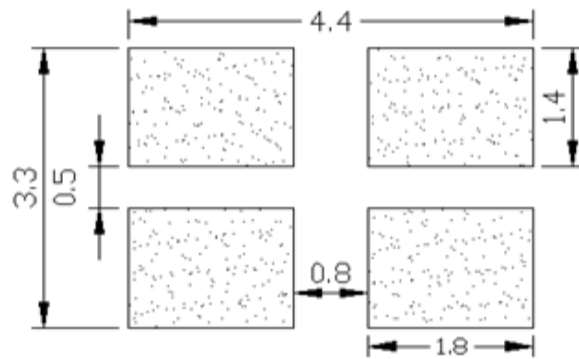

**Taping and package Spec**

- Tape Specification:2,000pcs Per Reel

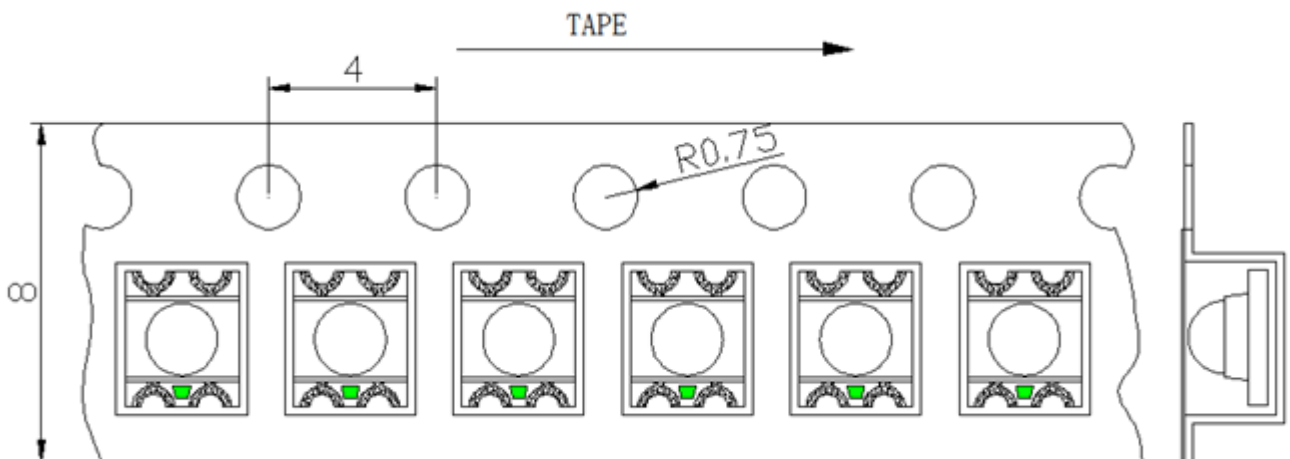

### Packaging

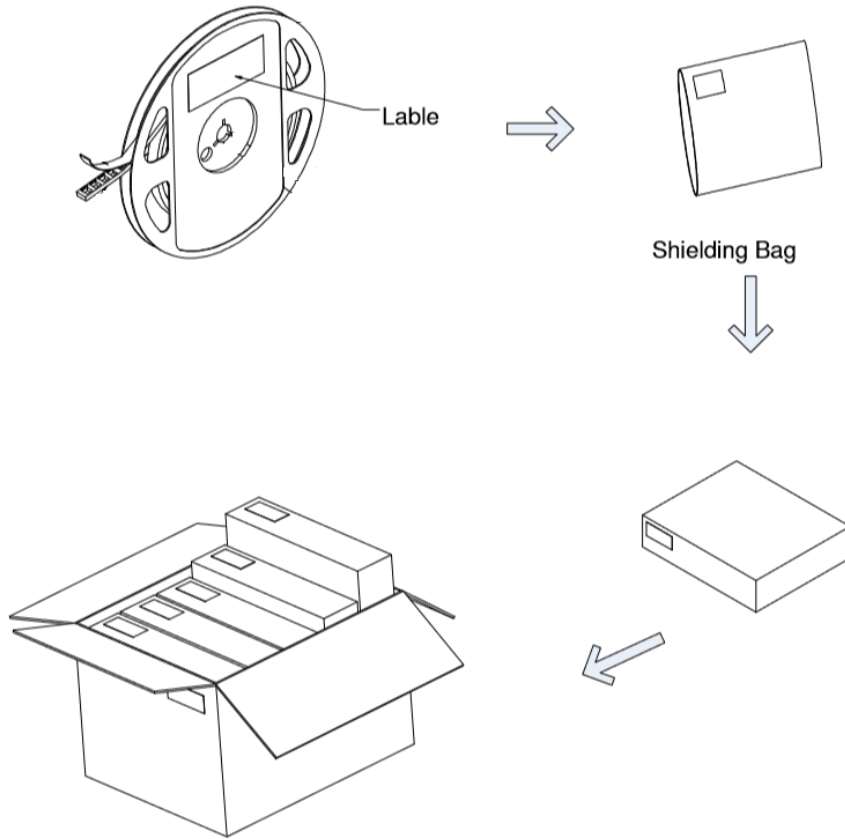

### LabelStyle

MANUFACTURER

  
P/N:XXXXXXXXXXXXXXXXXX

Emitting Color: XXXX

HUE: XXX-XXX nm

IV : XXX-XXX mcd **example**

VF: XX-XX V

QTY: XX PCS

BIN Code: XX

DATE: XXXX/XX/XX

  
LOT NO.:XXXXXXX

### Table of Classification Reflow Profiles

Profile Feature	Sn Pb Eutectic Assembly	Pb Free Assembly
Preheat & Soak	100 °C	150 °C
Temperature min (T <sub>min</sub> )	150°C	200 °C
Temperature max (T <sub>max</sub> )	60 120 seconds	60 120 seconds
Time (T <sub>min</sub> to T <sub>max</sub> ) (t <sub>s</sub> )		
Average ramp up rate (T <sub>max</sub> to T <sub>p</sub> )	3 °C/second max	3 °C/second max
Liquidous temperature (T <sub>L</sub> )	183 °C	217 °C
Time at liquidous (t <sub>L</sub> )	60 150 seconds	60 150 seconds
Peak package body temperature (T <sub>p</sub> )*	230 °C ~235 °C	255 °C ~260 °C
Classification temperature (T <sub>c</sub> )	235 °C	260 °C
Time (t <sub>p</sub> ) within 5 °C of the specified Classification temperature (T <sub>c</sub> )	20 seconds	30 seconds
Average ramp down rate (T <sub>p</sub> to T <sub>max</sub> )	6 °C/second max	6 °C/second max
Time 25 °C to peak temperature	6 minutes max	8 minutes max

1. Tolerance for peak profile temperature (T<sub>p</sub>) is defined as a supplier minimum and a user maximum.
2. Tolerance for time at peak profile temperature (t<sub>p</sub>) is defined as a supplier minimum and a user maximum.

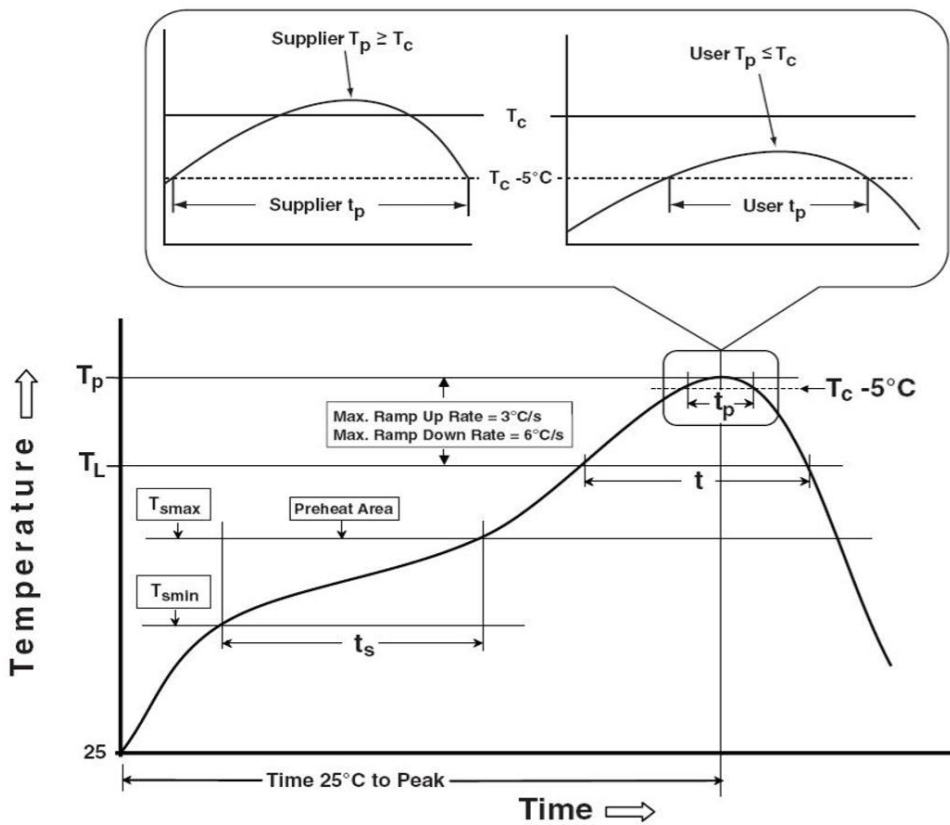

## Precautions

### 1. Storage:

- Moisture proof and anti electrostatic package with moisture absorbent material is used, to keep moisture to a minimum.
- Before opening the package, the product should be kept at 30°C or less and humidity less than 60% RH, and be used within a year.
- After opening the package, the product should be stored at 30°C or less and humidity less than 10%RH. It is recommended that the product be operated at the workshop condition of 30°C or less and humidity less than 60%RH.
- If the moisture absorbent material has faded away or the LEDs have exceeded the storage time, baking treatment should be performed based on the following condition: (70±5)°C for 24 hours.

### 2. Static Electricity:

Static electricity or surge voltage damages the LEDs. Damaged LEDs will show some unusual characteristics such as the forward voltage becoming lower, or the LEDs do not light at the low current, even not light.

All devices, equipment and machinery must be properly grounded. At the same time, it is recommended that wrist bands or anti electrostatic gloves, anti electrostatic containers be used when dealing with the LEDs.

### 3. Vulcanization:

LED curing is due to sulfur being in brackets and the +1 price of silver in the chemical reaction generated Ag<sub>2</sub>S in the process. It will lead to the capacity of reflecting of silver layer reducing, light color temperature drift and serious decline, seriously affecting the performance of the product. So we should take corresponding measures to avoid vulcanization, such as to avoid using sulphur volatile substances and keeping away from high sulphur content of the material.