

DATA SHEET

Revise History

Rev.	Descriptions	Date	Pag
1.0	-	23-10-2009	-
2.0	Renew form	15-12-2015	-
2.1	Renew form	10-11-2018	-
2.2	Renew form	27-12-2021	-
2.3	Renew form	23-10-2023	-
2.4	Renew form	10-10-2024	-



Features

- Long operating life.
- RoHS Compliant.
- Anti-UV colloid.
- Moisture sensitivity level: 4

Application

- Special lighting, Architectural lighting, Indoor and Outdoor Commercial lighting.
- Car lights, Traffic lights

Part Number	Dice Material	Emitted Color	Lens Color
IE-5050R-SB-LUV-CE	AlGaInP	Red	Semi-transparent

Electro-Optical Characteristics (Ta=25°C)

Parameter	Symbol	Min.	Typ.	Max.	Unit	Test Condition
Forward Voltage	V _F	1.80	2.00	2.40	V	IF=3*50mA
Luminous Flux ^{*1}	Φ	25	-	35	lm	
Radiation Bandwidth	Δλ	-	20	-	nm	
Color Rendering Index	R _a	-	-	-	-	
CIE Coordinates	x,y	-				
Peak Wavelength	λ _p	-	630	-	nm	
Dominant Wavelength	λ _d	618	620	628	nm	
Viewing Angle ^{*2}	2θ _{1/2}	-	30	-	deg	
Reverse Current	I _R	-	-	10	uA	VR=5V

Notes
1.A Luminous Flux is measured with a light sensor and filter combination that approximates the CIE eye-response curve.

2.2θ_{1/2} is the o-axis angle where the luminous intensity is 1/2 the peak intensity.

Absolute Maximum Ratings (Ta=25°C)

Parameter	Symbol	Max.	Unit
		Red	
Power Dissipation	P _d	360	mW
Peak Forward Current ^{*1}	I _{FP}	100*3	mA
Forward Current	I _F	60*3	mA
Junction Temperature	T _j	≤125	°C
Junction Solder Point	R _{THJS}	20	°C/W
Operating Temperature Range	T _{opr}	-40to+85	°C
Storage Temperature Range	T _{stg}	-40to+90	°C
Reflow Soldering	T _{slid}	260°C for 5 secs	

Notes : 1.Duty Factor=10%, Frequency=1kHz.

Optical & Electrical Characteristics Curves

Relative Intensity vs.Wavelength

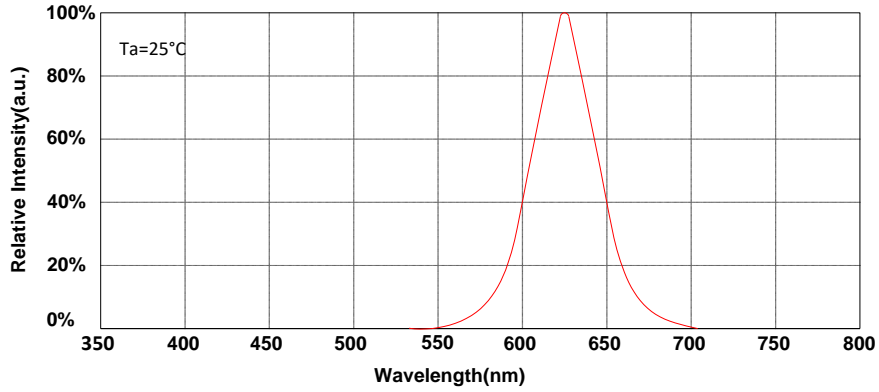

Forward Current vs.Forward Voltage

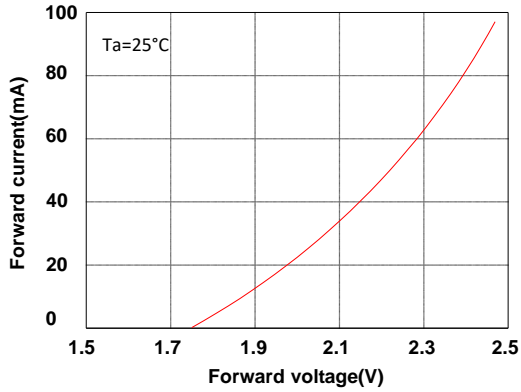

Luminous Flux vs. Forward Current

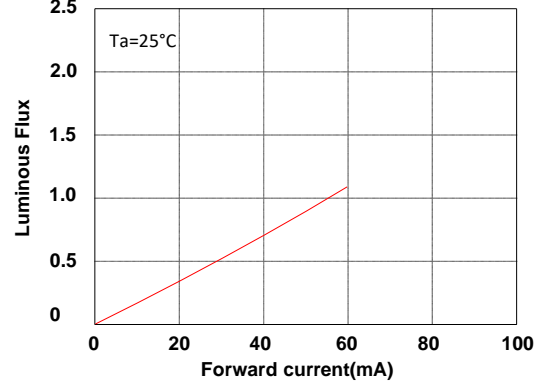

Forward Current Derating Curve

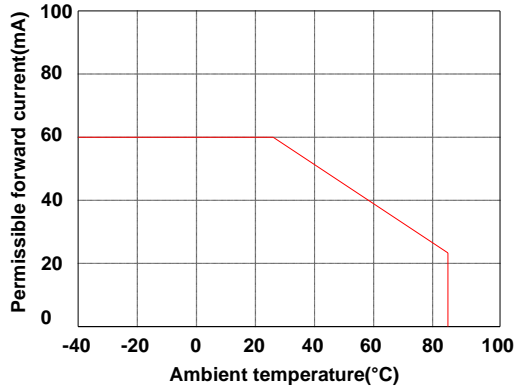

Luminous Flux vs.Ambient Temperaturs

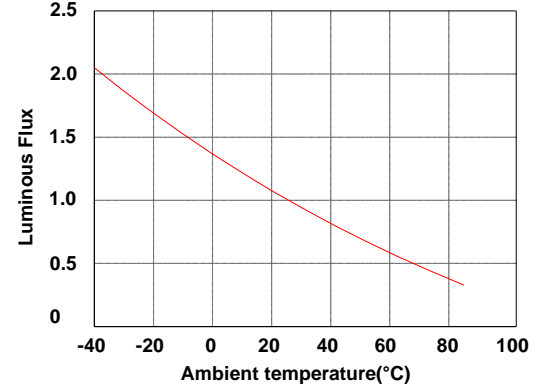

Spatial Distriution

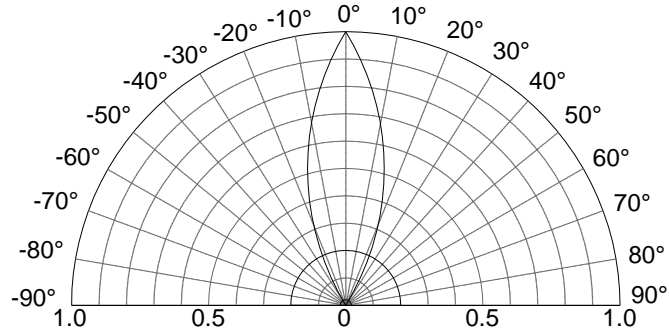

Electro-Optical Characteristics Bin Limits

Bin Range Of Wavelength

Bin Code	Min.	Max.	Condition
R1	618	622	IF=50mA*3
R2	622	626	
R3	-	-	
R4	-	-	
R5	-	-	

Bin Range Of Luminous Flux

Bin Code	Min.	Max.	Condition
L1	25	35	IF=50mA*3
L2	-	-	
L3	-	-	
L4	-	-	
L5	-	-	

Bin Range Of Forward Voltage

Bin Code	Min.	Max.	Condition
V1	1.8	2.0	IF=50mA*3
V2	2.0	2.2	
V3	2.2	2.4	
V4	-	-	
V5	-	-	
V6	-	-	
V7	-	-	
V8	-	-	

Notes:

- 1.Luminous Flux measurement tolerance: $\pm 10\%$.
- 2.Wavelength measurement tolerance: $\pm 1\text{nm}$.
- 3.Forward voltage measurement tolerance: $\pm 0.1\text{V}$.

Package Dimension (Unit:mm,Tolerance:±0.20mm)

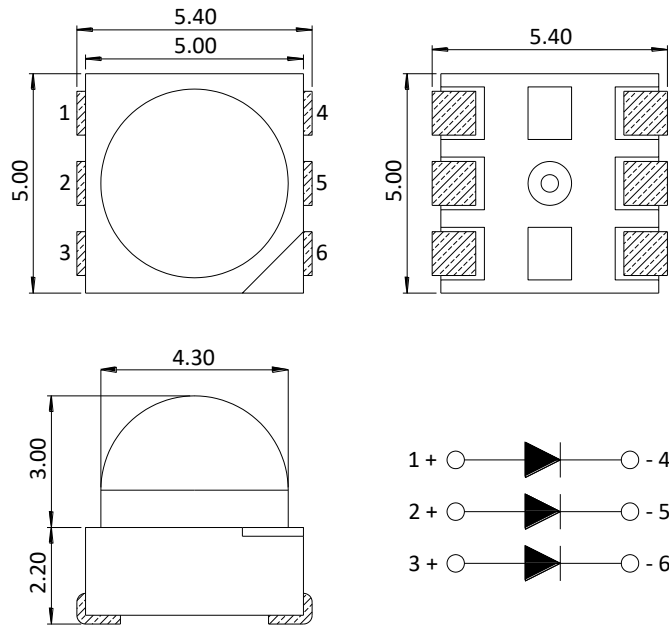

Recommended Soldering Pad Design (Unit:mm,Tolerance:±0.10mm)

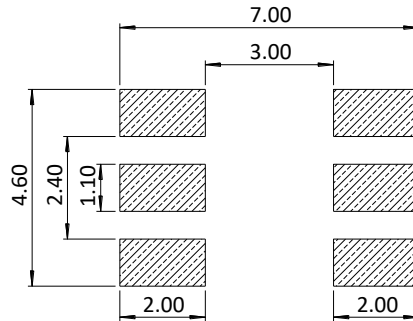

Carrier Tape Dimensions (Unit:mm,Tolerance:±0.10mm)

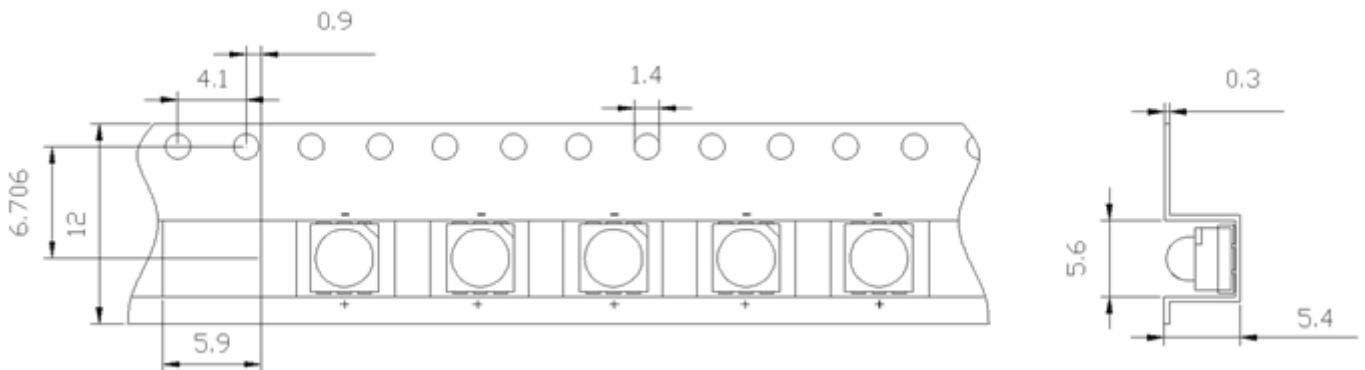

Reel Dimensions (Unit:mm,Tolerance: ±0.25mm)

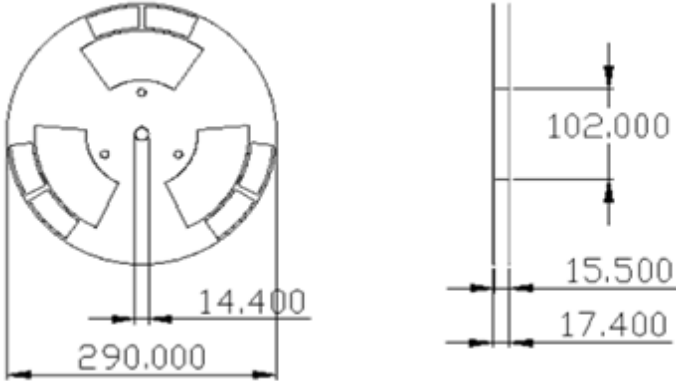

Packaging method

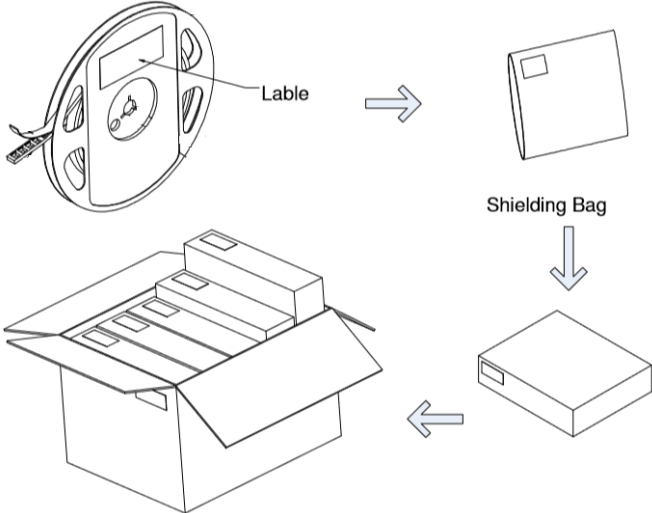

SMT Reflow Soldering Instructions

Profile Feature	Sn-Pb Eutectic Assembly	Pb-Free Assembly
Preheat & Soak	100°C	150°C
Temperature min (T _{smin})	150°C	200°C
Temperature max (T _{smax})	60-120 seconds	60-120 seconds
Time (T _{smin} to T _{smax}) (t _s)	-	-
Average ramp-up rate (T _{smax} to T _p)	3°C/second max	3°C/second max
Liquidous temperature (T _L)	183°C	217°C
Time at liquidous (t _L)	60-150 seconds	60-150 seconds
Peak temperature (T _p)*	230°C ~235°C	255°C ~260°C
Classification temperature (T _c)	235°C	260°C
Time (t _p) within 5°C of the specified Classification temperature (T _c)	20 seconds	30 seconds
Average ramp-down rate (T _p to T _{smax})	6°C/second max	6°C/second max
Time 25°C to peak temperature	8 minutes max	8 minutes max

1.Tolerance for peak temperature (T_p) is defined as a supplier minimum and a user maximum.

2.Tolerance for time at peak temperature (t_p) is defined as a supplier minimum and a user maximum.

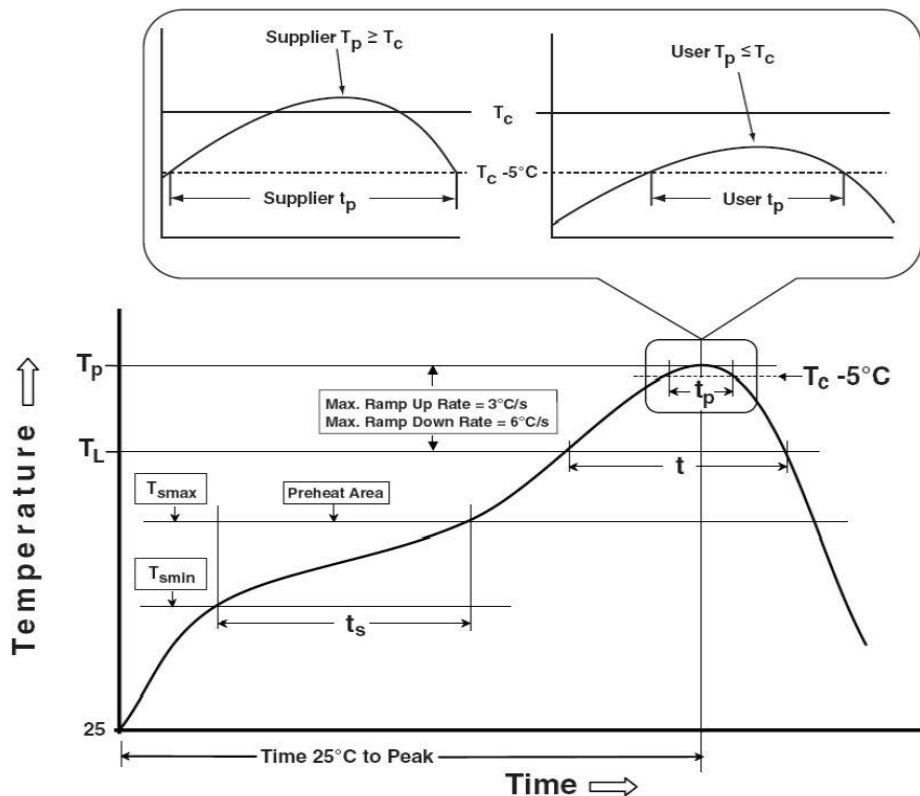

Precautions

1. Storage:

- Moisture proof and anti-electrostatic package with moisture absorbent material is used, to keep moisture to a minimum.
- Before opening the package, the product should be kept at 30°C or less and humidity less than 60% RH, and be used within a year.
- After opening the package, the product should be stored at 30°C or less and humidity less than 10%RH. It is recommended that the product be operated at the workshop condition of 30°C or less and humidity less than 60%RH.
- If the moisture absorbent material has faded away or the LEDs have exceeded the storage time, baking treatment should be performed based on the following condition: (70±5) °C for 24 hours.

2. Static Electricity :

- Static electricity or surge voltage damages the LEDs. Damaged LEDs will show some unusual characteristics such as the forward voltage becoming lower, or the LEDs do not light at the low current. All devices, equipment and machinery must be properly grounded. At the same time, it is recommended that wrist bands or anti-electrostatic gloves, anti-electrostatic containers be used when dealing with the LEDs.

3. Vulcanization :

- LED curing is due to sulfur being in brackets and the +1 price of silver in the chemical reaction generated Ag₂S in the process. It will lead to the capacity of reflecting of silver layer reducing, light color temperature drift and serious decline, seriously affecting the performance of the product. So we should take corresponding measures to avoid vulcanization, such as to avoid using sulphur volatile substances and keeping away from high sulphur content of the material.

4. Handling Precautions

- Handle the component along the side surfaces by using forceps or appropriate tools.
- Do not directly touch or handle the epoxy resin lens surface. It may damage the internal circuitry.
- Do not stack together assembled PCBs containing exposed LEDs. Impact may scratch the epoxy resin lens or damage the internal circuitry.