

Part Number: IE-10WW-UB-C-F

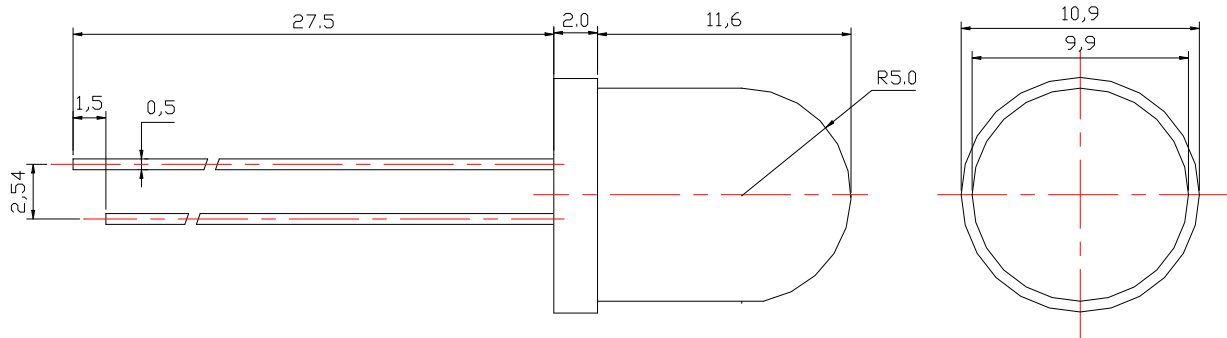

Notes:

- 1.All dimension units are millimeters.
- 2.All dimension tolerance is $\pm 0.2\text{mm}$ unless otherwise noted.
- 3.An epoxy meniscus may extend about 1.5mm down the leads.
- 4.Burr around bottom of epoxy may be 0.5mm max..

■ Features:

- Choice of various viewing angles.
- Available on tape and reel.
- Reliable and robust.

■ Descriptions:

- The series is specially designed for application requiring higher brightness.

■ Applications:

- Backlight
- Monitor
- Traffic light

Chip		Lens Color
Material	Emitting Color	
InGaN	White	Clear lens

■ Absolute Maximum Ratings at Ta=25 °C

Parameter	Symbol	Rating	Unit
Forward Current	IF	20	mA
Operating Temperature	Topr	-25 to +80	°C
Storage Temperature	Tstg	-40 to +100	°C
Soldering Temperature	Tsol	260	°C
Power Dissipation	Pd	50	mW
Peak Forward Current (Duty1/10@1kHz)	IF(Peak)	100	mA
Reverse Voltage	VR	5	V

■ Electronic Optical Characteristics

Parameter	Symbol	Min.	Typ.	Max.	Unit	Condition
Luminous Intensity	Iv	18000		22000	mcd	IF=20mA
Viewing Angle	2θ½	/	40	/	deg	IF=20mA
Peak Wavelength	λp	/	/	/	nm	IF=20mA
Color Temperature	λd	2700		3000	K	IF=20mA
Forward Voltage	Vf	2.8	3.2	3.4	V	IF=20mA
Reverse Current	IR	/	/	10	μA	VR=5V

Suggestions to customers

- 1、 Soldering Bath at $260\text{ }^{\circ}\text{C} \pm 5\text{ }^{\circ}\text{C}$ with in 3 seconds.(Dip depth should under 6mm below seating plane.)
- 2、 Soldering Iron-Under 40W with 3 seconds.(Tip temperature: $205\text{ }^{\circ}\text{C} \pm 5\text{ }^{\circ}\text{C}$)
- 3、 The neutrality flux must be used before soldering.

CLEANING

Do not use unspecified chemical liquid to clean LED.They could harm it IF cleaning is necessary, wipe the pin out with alcohol、 Freon TE or Chlorosen at normal temperature for less than 1 minute or wipe the surface with alcohol.

METHODS AGAINST STATIC ELECTRICITY

Static electricity is the enemy of lamps emitting blue and green. Workers must put on working rings、 gloves clothes that protect static electricity while working. Wires of the rings keep well together with the floor and there must be wires to connect the irons and the floor.

PREVENTING OVERCURRENT

- 1、 Be not overcurrent.
- 2、 In order to cooperate LEDs under stable conditions, put protective resisetor in seride. Resistor values can be determined by supplying voltage or current for the LEDs Recommended current is in the range of forward current 5mA-20mA.
- 3、 Circuit must be designed so that overvoltage is not applied the LED during on/off switching. Transient or pulse current will damage junction of LED die.

■Reliability Performance

(1) TEST ITEMS AND RESULTS

Type	Test Item	REF Standard	Test Conditions	Note	Number of Damaged
Environmental Sequence	Resistance to Soldering Heat (Reflow Soldering)		Tsld=230 °C ,10sec	2times	0/22
	Temperature cycle	JIS C 7021 (1977)A-4	-20°C 30min 5min 80°C 30min	100 cycle	0/100
	Thermal Shock	MIL-STD-107D	-20°C 15min 80°C 15min	100cycle	0/100
	High Temperature Storage	JIS C 7021 (1977)B-10	Ta=80°C	1000hrs	0/100
	Temperature Humidity Storage	JIS C 7021 (1977)B-11	Ta=60°C RH=90%	1000hrs	0/100
	Low Temperature Storage	JIS C 7021 (1977)B-12	Ta=30°C	1000hrs	0/100
Operation Sequence	Life Test	JIS C 7035 (1985)	Ta=25°C IF=20mA	1000hrs	0/100
	High Humidity Heat Life Test		60°C RH=90% IF=20mA	500hrs	0/100
	Low Temperature Life Test		Ta=20°C IF=20mA	1000hrs	0/100
	Drop		75cm	3times	0/10

(2).Criteria for Judging The Damage

Item	Symbol	Test Conditions	Criteria for Judgment	
			Min	Max
Forward Voltage	VF	IF=20mA		U.S.K*1.2
Reverse current	IR	VR=5V		U.S.L*2.2
Luminous Intensity	IV	IF=20mA	L.S.L**x0.7	

U.S.L*:Upper Standard Level

L.S.L**:Lower Dstandard Level

Optical characteristics curves

