

SPECIFICATION

- ◆ P/N NO: IE-1616RG-ST-BBI-A1
- ◆ S/N NO:
- ◆ Document. NO:
- ◆ REV NO: V4.0
- ◆ Description:
 - 1.6×1.6mm Chip SMD
 - Colloid Color: White diffused
 - Emission Color: Red Green
 - Viewing Angle :120°

1. Dimensions

(Units): (mm)

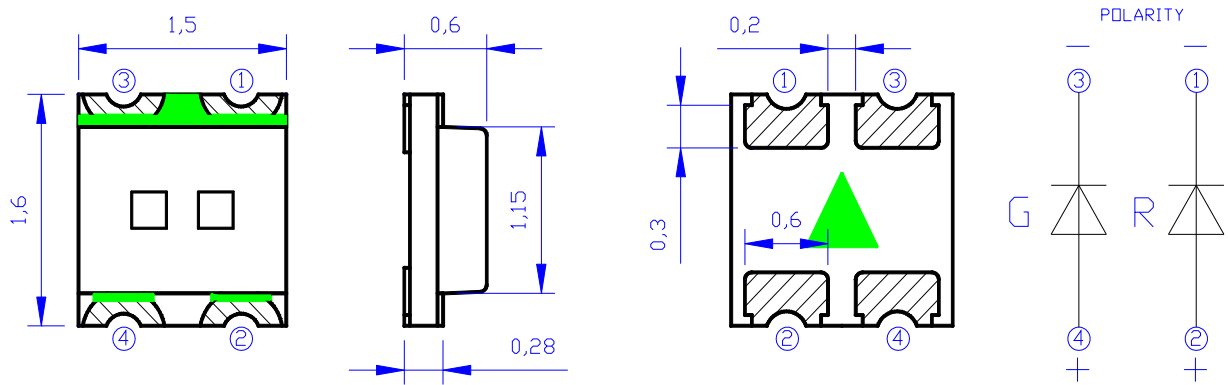

All dimensions area in mm tolerance is $\pm 0.05\text{mm}$ unless otherwise noted.

2. Electrical / Optical characteristics

(1) Absolute Maximum Ratings (TA=25±5°C)

| Item | Symbol | Absolute Maximum Rating | | Unit |
|-------------------------------|--------|---|-----|-------------------------|
| | | Green | Red | |
| Forward Current | IF | 20 | 20 | mA |
| Pulse Forward Current | IFP | 50 | 50 | mA |
| Power Dissipation | PD | 68 | 44 | mW |
| Reverse Voltage | VR | 9 | | V |
| LED Pad Operating Temperature | Topr | -30°C To +85°C | | ° C |
| Storage Temperature | Tstg | -40°C To +100°C | | ° C |
| Soldering Temperature | Tsld | Reflow Soldering: 260°C Hand Soldering : 300°C | | for 10sec. for 3sec. |

IFP Conditions: 1/10 Duty Cycle, 0.1 msec Pulse Width.

(2) Initial Electrical/Optical Characteristics (TA=25±5°C).

| Symbol | Item | Units | Device | Min. | Typ. | Max. | Test Conditions |
|----------------------|---------------------|-------|--------|------|------|------|-----------------|
| VF | Forward Voltage | V | Red | 1.8 | | 2.3 | IF=20mA |
| | | | Green | 2.6 | | 3.2 | IF=20mA |
| IR | Reverse Current | uA | - | - | - | 5 | VR=5V |
| $\Delta \lambda 1/2$ | Viewing Angle | ° | - | - | 120 | - | IF=20mA |
| Iv | Luminous Intensity | Mcd | Red | 100 | | 120 | IF=20mA |
| | | | Green | 210 | | 350 | IF=20mA |
| λD | Dominate Wavelength | Nm | Red | 620 | | 625 | IF=20mA |
| | | | Green | 516 | | 530 | IF=20mA |

Tolerance of measurement of Vf is ±0.05 V.

Luminous Intensity Measurement allowance is ± 10%.

Color Coordinates Measurement allowance is ± 1nm.

Above are the reference for minimum and maximum of luminous intensity which rank in the rate of 1:1.3 in the process of light splitting when manufacturing massively.

Above are the reference for minimum and maximum of wavelength, while it ranks as:R:5nm/G:3nm.when light splitting in mass manufacturing.

3. Characteristic curve

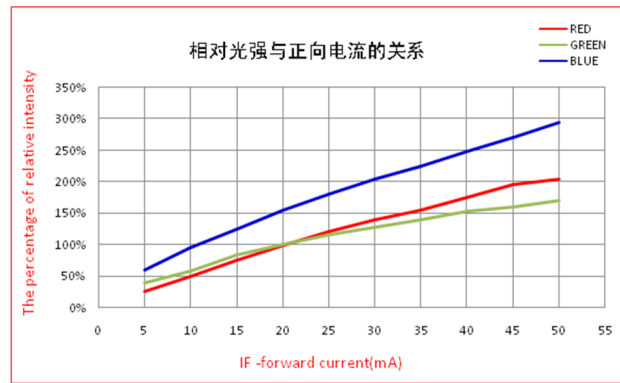
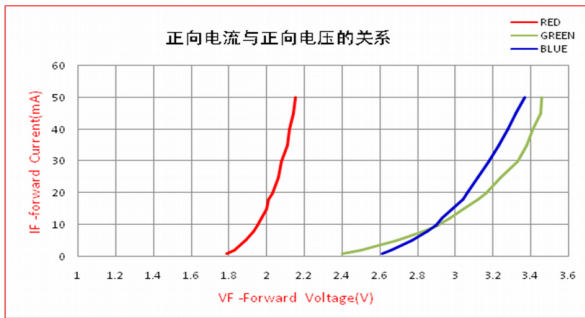
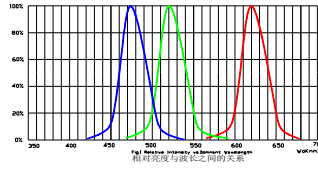

正向电流与温度关系曲线图

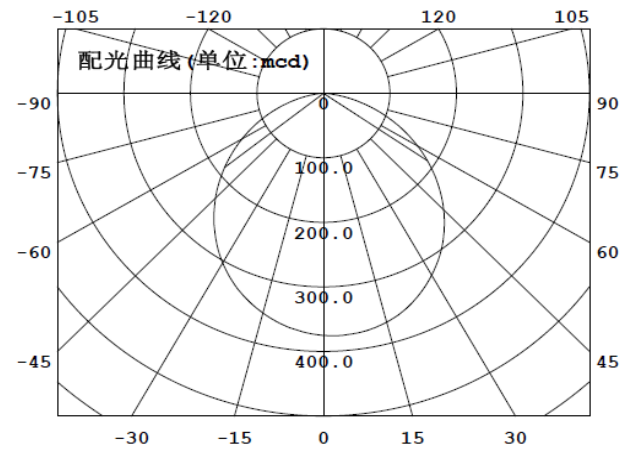
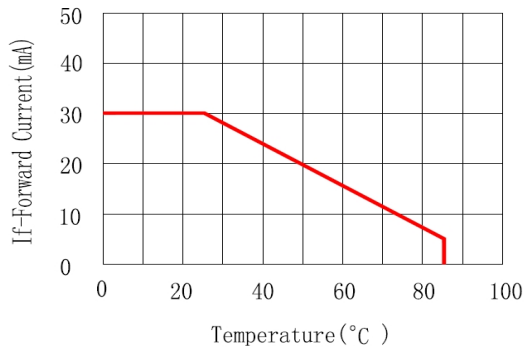

亮度与环境温度关系曲线图

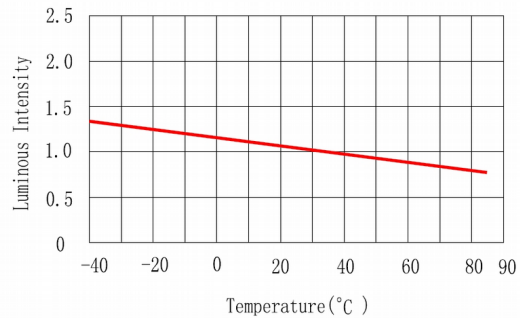

4. RELIABILITY

Test Items and Results

| NO. | Test Items | Reference | Test condition | | Laboratory number | LTPD |
|---------|---|----------------------------|---|---------------|-------------------|------|
| 1 | temperature cycling test | EIAJ ED-4701 100 105 | -40℃~25℃~100℃~25℃ 30min ~5min ~30min~5min | 100 cycles | 22 | 0/22 |
| 2 | Thermal shock test | EIAJ ED-4701 300 307 | -40℃~100℃ 15min~15min | 500 cycles | 22 | 0/22 |
| 3 | High temperature storage test | EIAJ ED-4701 200 201 | Ta=100℃ | 1000 hrs | 22 | 0/22 |
| 4 | Low temperature storage test | EIAJ ED-4701 200 202 | Ta=-40℃ | 1000 hrs | 22 | 0/22 |
| 5 | Continuous operating test EIAJ ED-4701 100 101 | Ta=25±5℃ IF=10mA | 1000 hrs | 22 | 0/22 | |
| 6 | High temperature and humidity operating test | EIAJ ED-4701 100 102 | Ta=85℃ RH=85% IF=10mA | 1000 hrs | 22 | 0/22 |
| 7 | Soldering resistance test | EIAJ ED-4701 300 301 | Pre treatment: 35℃ 95%RH 96 Tsol=260℃, T=10s | 3times | 22 | 0/22 |
| 8 | MSL3 | IPC/JEDEC J- STD-020D.1 | 1. 125℃/24H 2. Ta=60℃ RH=60% 52H\ 3. Tsol=260℃, T=10s | 3times | 22 | 0/22 |
| Comment | All the tests such as with the customer requirements exist differences or special customer's special requirement, can according to the actual situation in accordance with the requirements of customers are trying, not required by the customer according to the standard of our test trial. Different products using different current test. | | | | | |
| | | | | | | |

5. Cautions

5.1 Soldering (Including manual and reflow soldering)

5.1.1 Hand Soldering

Welding when the temperature of the soldering iron must be kept below 300 ℃, and each can only make a welding electrode, the duration of each welding should not more than 3 seconds. Due to the small size of leds, the use of manual welding are harder to control welding temperature and tin time consistency, and easy to destroy the light body structure, serious when can cause the LED failure, so please use reflow welding machine operation.

5.1.2

Reflow soldering: it is recommended to use the following figure for lead-free reflow soldering temperature.

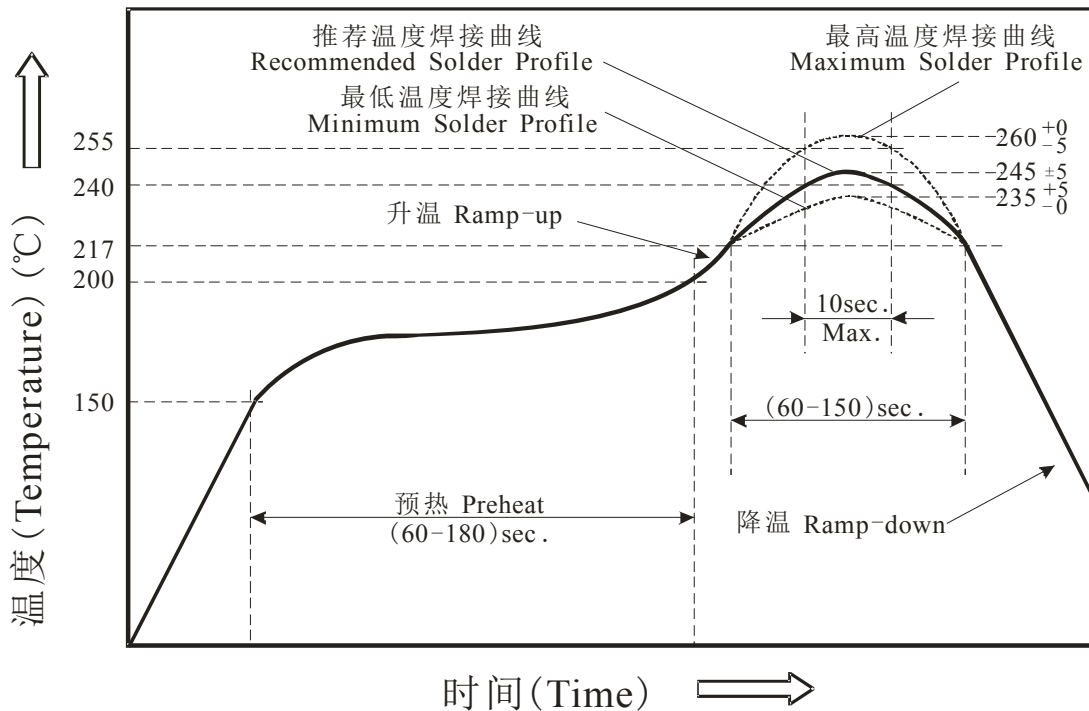

Note: the reflow soldering only twice, in the process of reflow soldering temperature, please don't impose any pressure on the LED. After completion of welding, after the product after cooling to room temperature, and other processing.

5.2 storage

This product use sealed moisture-proof anti-static aluminum foil bag bag with desiccant, handling should be avoided in the process of extrusion, prick bags happens, at the same time to avoid the reliability of the product be affected with damp be affected with damp cause failure problem, need to be LED products storage and moisture-proof measures before welding.

5.2.1

Kaifeng before, the LED product in temperature is not higher than 30 ℃, humidity is not higher than 60% RH save time for 90 days in the environment.

5. 2. 2

After opening, the LED product must be stored in a temperature is not higher than 30 °C, humidity is not higher than 60% RH of the environment, and should be used up within 24 hours

5. 2. 3

For the LED not welding, if the packing failure, or product is not conform to the above and effective storage conditions, to be baked 60°C / 24h.

5. 3 Electrostatic protection

5. 3. 1

Static and transient causes product characteristics change, such as forward voltage to reduce, if severe cases may even damage the product. So for the entire process (production, testing, packaging, etc.) in direct contact with the LED workers to make measures to prevent and eliminate static electricity.

5. 3. 2

All related equipment and machines should be properly grounded, grounding ac resistance is less than 1.0 ohms, workbench to pad surface resistance is 10⁶-10⁹ Ω table mat.

5. 3. 3

In easy to produce static environment and equipment, must also be installed ion fan, operator need to use anti-static bracelet in the process of operation, anti-static MATS, anti-static overalls, work shoes, gloves, anti-static container, etc., take put material with colloid part as much as possible.

5. 4 Other items

5. 4. 1

Very fragile epoxy resin encapsulation part of LED products, please do not use hard, sharp objects scratching encapsulating resin parts, use tweezers clip also should be careful when you pick up the LED.

5. 4. 2

Please do not directly by hand take LED products: directly with the hand take LED products will not only pollution encapsulating resin surface, may also be due to factors such as electrostatic leads to a change in product performance.

5. 4. 3

Please do not put too much pressure on LED product, especially when LED products under high temperature condition (for example) in the process of reflow soldering, excessive stress can directly affect the sealed tube core and gold thread.

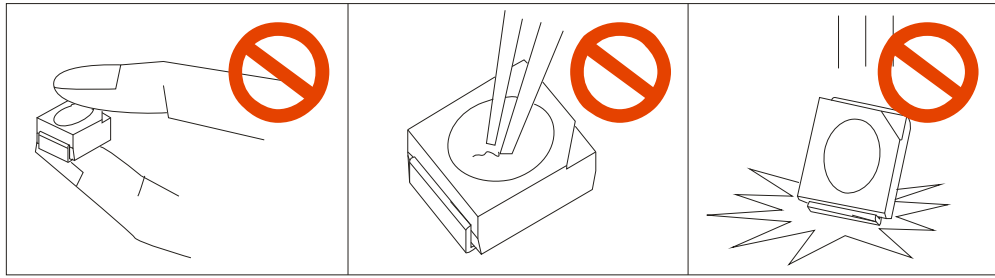

6. PACKAGING

- (1) The LED are packed in cardboard boxes after taping.
- (2) Taping Specifications (Units:mm)

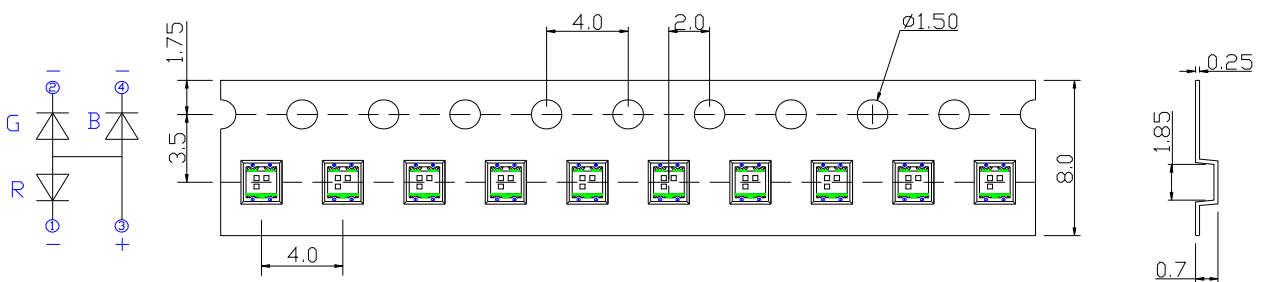

- (3) Reel Dimension

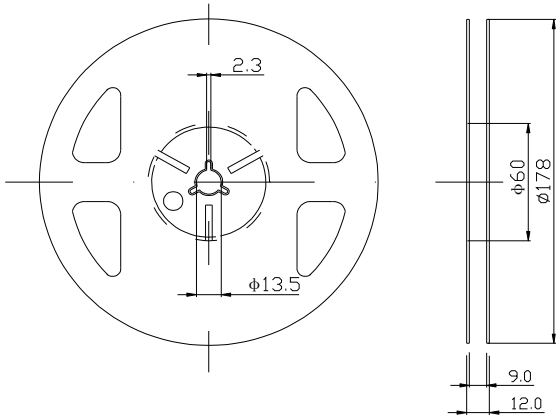

PACKAGE:4000Pcs/Reel.

- (4) The label on the minimum packing unit shows ; Part Number, Lot Number, Ranking, Quantity.
- (5) Keep away from water, moisture in order to protect the LED.
- (6) The LED may be damaged if the boxes are dropped or receive a strong impact against them. so precautions must be taken to prevent any damage.

Label details:

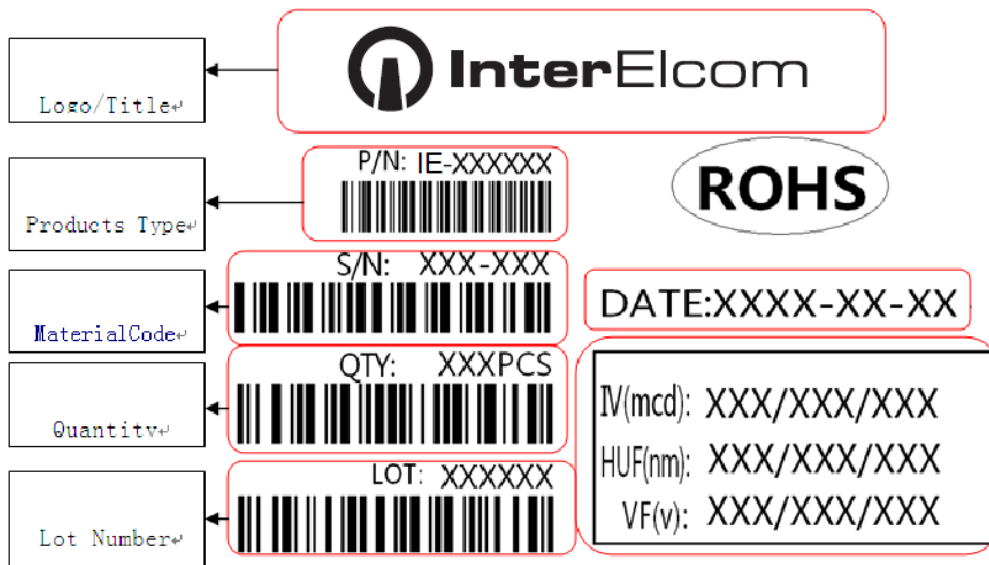

Notes of Label:

- ① Please make sure the type of our smd products, different types cannot be mixed when using.
 - ② Products in different lot number cannot be used in one display panel together ,even with the same type and parameter.
 - ③ Different type of products with same parameter cannot be mixed and used.
-
- (1) If necessary, please use leaded soldering as more as possible.
 - (2) High temperature cause serious heat damage to LED products, make sure the temperature of the soldering area is below 230°C.