

specification for approval

客户 (Customer) :

客户料号 (customer part no) : IE-10R630-ST-D-CFT

客户型号 (customer part no) :

产品品名 (Product name) :

产品型号 (Product Model) : IE-10R630-ST-D-CFT

Customer Signatures	Inspection	Production



ATTENTION 注意
 OBSERVE PRECAUTIONS
 FOR HANDLING
 ELECTROSTATIC
 DISCHARGE
 SENSITIVE
 DEVICES
 请勿裸手接触器件

Features (特征)

φ 10LAMP LED 直插φ 10LED 灯

Long life-solid state reliability 寿命长

Low power consumption 低能耗

IDEAL FOR BACKLIGHT AND INDICATOR.

用于背光和指示

Package Dimensions 封装尺寸

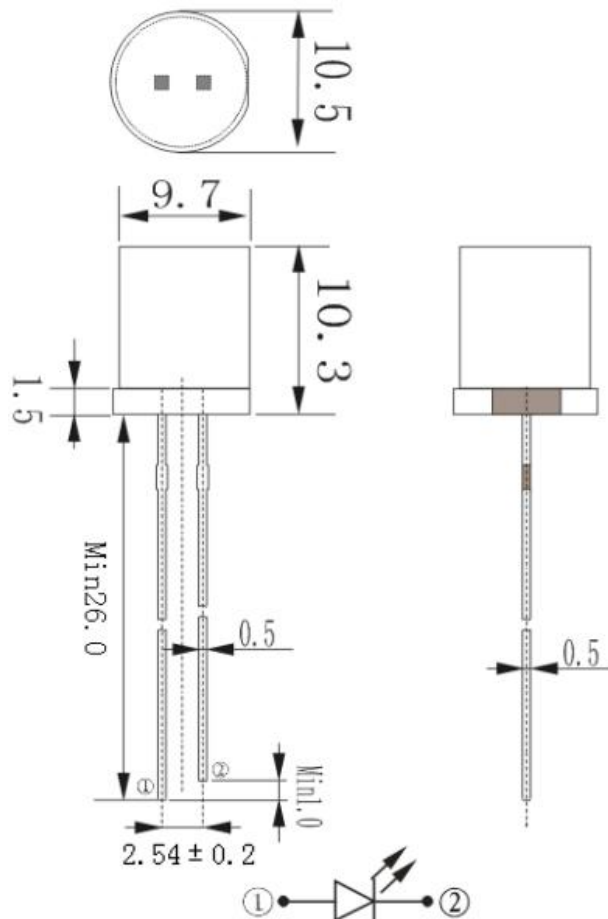

Tolerance Grade 公差等级	Dimension Tolerance (UNIT:mm) 尺寸公差 (单位:mm)			
	0.5~3	3~6	6~30	30~120
	± 0.1	± 0.2	± 0.3	± 0.5
CHIP Emitting Color 发光颜色	Red 红色	Lens Color 透镜颜色	White Diffused 白色散射	

■ Absolute Maximum Rating (最大数值)

Item 项目	Symbol 符号	Value 数值	Unit 单位
Forward Current 正向电流	IF	30	mA
Peak Forward Current* 峰值正向电流	IFP	100	mA
Reverse Voltage 反向电压	VR	6	V
Power Dissipation 功耗	PD	60	mW
Electrostatic discharge 抗静电能力(HBM)	ESD	1000	V
Operation Temperature 操作温度	Topr	-25~ +100	°C
Storage Temperature 储存温度	Tstg	-40~ +100	°C
Lead Soldering Temperature*引脚焊接温度	Tsol	Max. 265°C for 5sec Max.	--

*IFP Conditions : F=1KHZ, Duty cycle 1/10 (正向峰值电流条件 : F=1KHZ, 占空比为 1/10)

*Tsol Conditions : 1.5mm from the base of the epoxy bulb

(Tsol 焊接条件 : 焊接位置离胶体底部 1.5mm)

■ Typical Optical/ Electrical Characteristics Ta=25°C (光电参数 环境温度 25°C)

Item (项目)	Symbol 符号	Condition 条件	Min. 最小值	Typ. 典型值	Max. 最大值	Unit 单位
Luminous Intensity 光强	Iv	IF=20mA	170	350	570	mcd
Forward Voltage 正向电压	VF		1.6	2.0	2.4	V
Viewing Angle 角度	2θ 1/2		--	180	--	deg
peak wavelength 峰值波长	λp		--	629	--	nm
Dominant Wavelength 主波长	λD		618	621	630	nm
Reverse Current 反向电流	IR	Vr=5V	--	--	10	uA

Notes (注释) :

Tolerance : $V_F \pm 0.1V$, $\lambda d \pm 2 \text{ nm}$, $I_V(\varphi V) \pm 15\%$ 公差 : 正向电压 $\pm 0.1V$, 主波长 $\pm 2 \text{ nm}$, 光强 (光通量) $\pm 15\%$

■ Reliability Performance 可靠性

Test Items And Result 测试项目和判定

Test Classification 测试类别	Test Item 测试项目	Test Conditions 测试条件	Test Duration 测试持续时间	Sample Size 样品数量	AC/RE 接受/拒收
Life Test 寿命测试	Room Temperature DC Operating Life Test 室温直流寿命测试	$T_a=25^\circ\text{C} \pm 5^\circ\text{C}$, $I_f=20\text{mA}$	1000hrs	22 pcs	0/1
Environment Test 环境模拟 实验	Thermal Shock Test 冷热冲击	$100^\circ\text{C} \pm 5^\circ\text{C}$ 5min ↑ ↓ $-40^\circ\text{C} \pm 5^\circ\text{C}$ 5min.	100 cycles	22 pcs	0/1
	Temperature Cycle Test 高低温循环实验	$100^\circ\text{C} \pm 5^\circ\text{C}$ 30min ↑ ↓ 5min $-40^\circ\text{C} \pm 5^\circ\text{C}$ 30min.	100 cycles	22 pcs	0/1
	High Temperature & High Humidity Test 高温高湿实验	$85^\circ\text{C} \pm 5^\circ\text{C}/85\% \text{ RH}$ $I_F=20\text{mA}$	1000 hrs	22 pcs	0/1
	High Temperature Storage 高温储存	$T_a=100^\circ\text{C} \pm 5^\circ\text{C}$	1000 hrs	22 pcs	0/1
	Low Temperature Storage 低温储存	$T_a=-40^\circ\text{C} \pm 5^\circ\text{C}$	1000 hrs	22 pcs	0/1
Mechanical Test 机械测试	Resistance to Soldering Heat 耐焊接实验	Temp= $260^\circ\text{C}_{\text{max}}$ T=5sec max	1times	22 pcs	0/1
	Lead Integrity 引脚折弯实验	Load 2.5N(0.25kgf) $0^\circ \sim 90^\circ \sim 0^\circ$	3times	22 pcs	0/1
Salt Spray Test 盐雾测试	Salt Spray Experiment 盐雾喷雾实验	$T_a=35^\circ\text{C}$ Spray quantity(ml/80cm ² /H)1.0~2.0ml Concentration(NaCl)5%	0hrs	22 pcs	0/1

RELATIVE INTENSITY VS WAVELENGTH

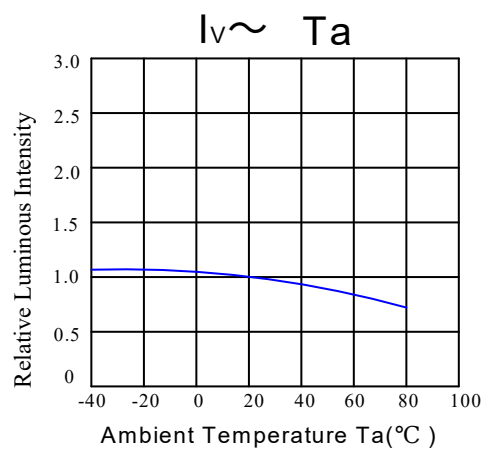
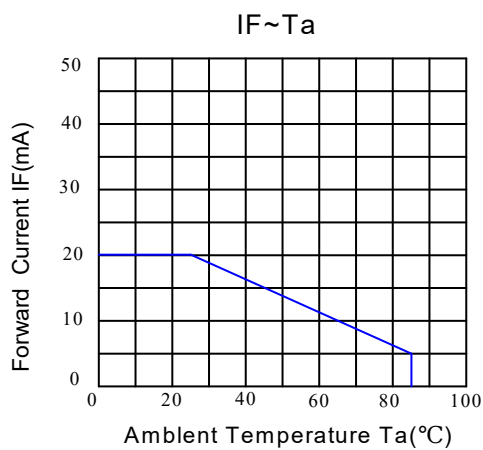
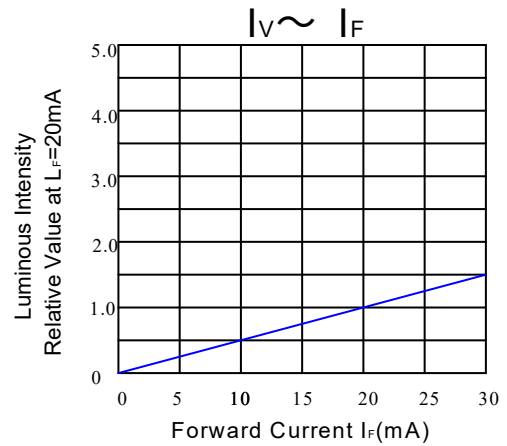
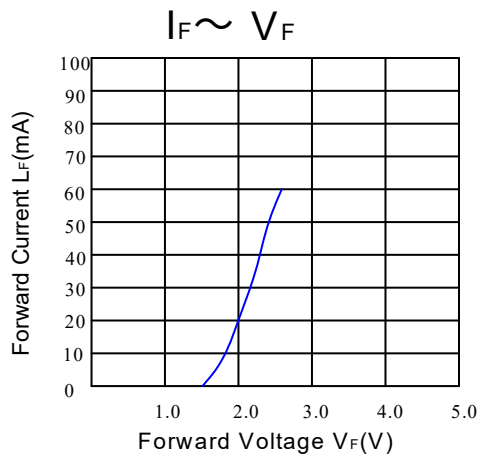
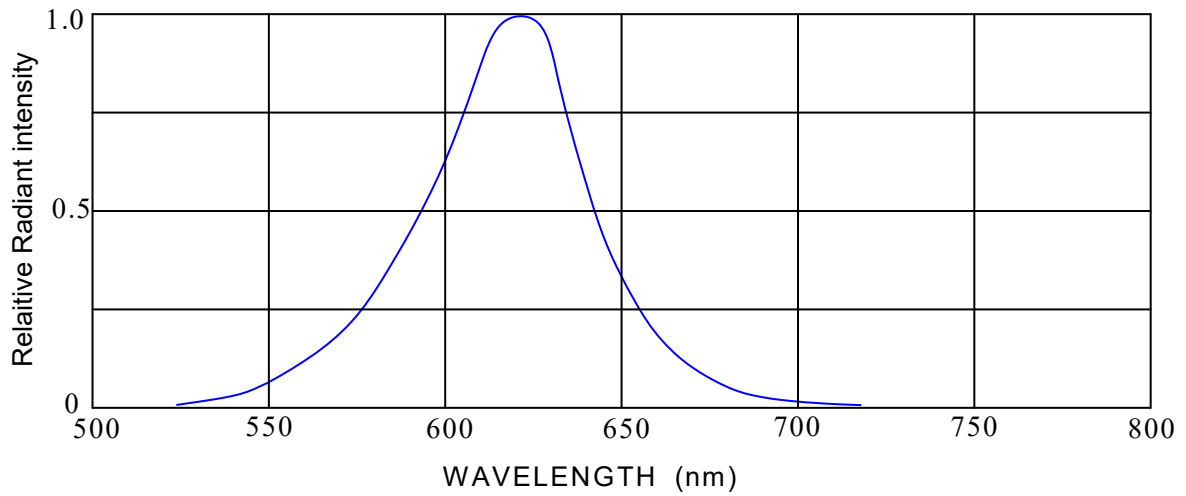

■ Parameter staging 参数档位划分

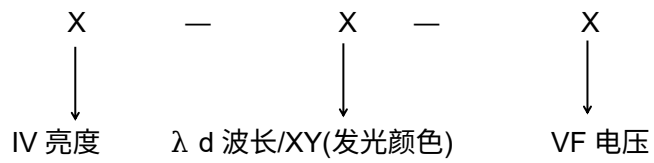

多颗相同 LED 产品一起使用时，注意确认包装袋上的 BIN 号及参数，一个 BIN 号及参数使用完成后再使用下一个 BIN 号，避免混 BIN 使用，造成产品之间出现颜色差异。

Precautions(使用注意事项)

1.Soldering (焊接) :

DIP soldering (Wave Soldering)波峰焊接:

Preheating:120°C~150°C,within 120~180 sec.(预热温度 120°C~150°C, 小于 120~180 秒)

Operation heating:260°C±5°C within 5 sec.265°C(Max)

操作温度：260°C±5°C小于 5 秒，最高温度不高于 265°C

Gradual Cooling (Avoid quenching).

过完波峰焊后应缓慢冷却。

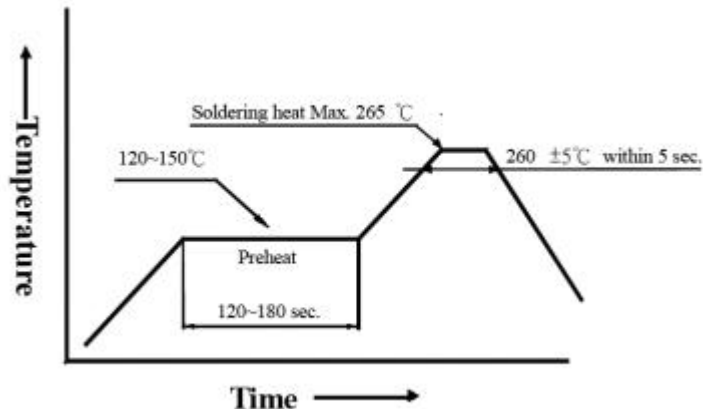

Be careful because damages always caused during soldering. Please note that stress to the leads and expose bulb should be avoided during soldering particularly when heated. When soldering, leave certain distance from soldering joint to base, the distance is determined by different soldering techniques.

焊接过程中的不慎操作将会引起产品的损坏，请务必注意。焊接过程中应避免对产品支架或封装部分施加压力。焊接时，请保证焊接位置与封装树脂底部有一定的距离，该距离因不同的焊接方法而有所不同。

Manual welding LED chips, can not weld LED two pins at the same time.

手动焊接 LED 灯珠时，不可以同时焊接 LED 的两个管脚。

This LED products can not be reflow soldering

此 LED 产品不可以过回流焊。

2.Storage (储存)

Under the storage conditions of 30°C or less and humidity less than 60%RH, the LEDs can be storage for 3months.

Storage in a sealed container with moisture absorbent material can prolong the storage time to a certain extent bad storage conditions may cause the lead frames to corrode or degradation of LED characteristics. It is recommended that the LEDs be used as soon as possible.

在温度低于 30°C，湿度不高于 60%RH 的条件下，产品保存期限为 3 个月。将产品保存在密封的容器中并附带干燥剂可以在一定程度上延续产品的储存日期。不良的储存条件会导致产品引脚的腐蚀或产品性能的改变。

3. Static electricity (静电)

Static electricity of surge voltage damages the LED .Damaged LED will show some unusual chrematistics such as the forward voltage becomes lower or the LED do not light at the low current even not light. All devices equipment and machinery must be properly grounded. At the same time, it is recommended that wrist Bands or anti-electrostatic gloves anti-electrostatic containers be used when dealing with the LED.

静电和电涌会导致产品特性发生改变，例如正向电压降低等，如果情况严重甚至会损毁产品，所以在使用时必须采取有效的防静电措施。所有相关的设备和机器都应该正确的接地，同时必须采取其他防静电和电涌的措施。使用防静电手环，防静电垫子，防静电工作服，工作鞋，手套，防静电容器，都是有效的防止静电和电涌的措施。

When the working environment of electrostatic value more than 1000 v, it is recommended to use zener diode LED lamp bead.

当工作环境的静电值超过 1000V 时，建议使用 LED 齐纳二极管灯珠。

4. Design Consideration (设计建议)

When designing a circuit, the current through each LED must not exceed the absolute maximum rating specified for each LED .In the meanwhile , resistors for protection should be applied otherwise slight voltage shift will cause big current change, bum out may happen.

Thermal Design is paramount important in because heat generation may result in the Characteristics decline, such as brightness decreased, Color changed and so on. Please consider the heat generation of the LED when making the system design.

设计电路时，通过 LED 的电流不能超过规定的最大值，同时还需要使用保护电阻，否则微小的电压变化将会引起较大的电流变化，可能导致产品损毁。

LED 的特性容易因为自身的发热和环境的温度的改变而发生改变。温度的升高会降低 LED 的发光效率，影响发光颜色等，所以在设计时应充分考虑散热的问题。

LED working status can not be more than 6 volts.

LED工作状态下反向电压不可超过 6V。

5. Lead Forming (支架整形)

Any lead forming must be done before soldering, not during or after soldering. When forming leads ,the leads should bent at a point at least 3mm from the base of the expose bulb. Bending at the same point twice or even more should be avoided.

Please use proper tools to hold and bent the leads, do not use the base of the lead frame as a fulcrum during lead forming .Bending s tress to the base of the lead frame may cause character is tics change on LED or even break it.

Just for the same reason, when mounting the LED on to printed circuit board, the holes on the circuit board should be exactly aligned with the leads of the LED.

支架的整形必须在焊接之前进行。整形时，支架的弯曲位置必须至少在封装树脂底部 3mm 处，同时避免对同一位置进行多次的弯曲。整形时，请使用合适的工具固定支架，避免对树脂施加压力。特别是不能管脚与树脂的连接部分作为支点，这样产生的应力会直接对产品内部的发光结构造成损伤，导致产品特性的改变甚至损毁。基于同样的原因，在装配产品的时候，PCB 板上焊孔间的距离必须于产品的管脚间距严格匹配。

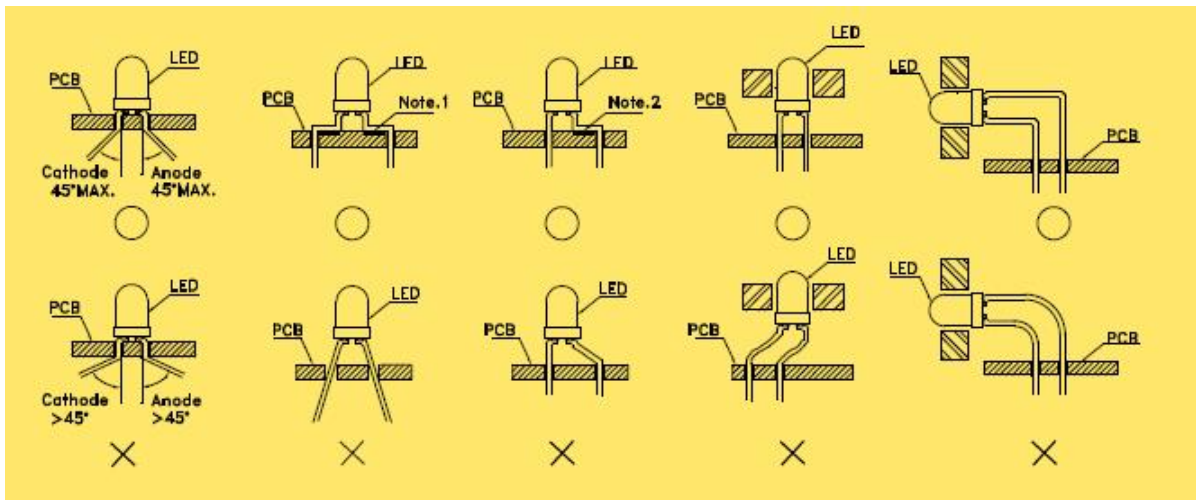

LED flat or make AI, suggest using $\Phi 4$, $\Phi 5$ LED chips, to avoid LED chips cracking caused by outside force, and please note dynamics for AI.

LED平贴板或打 AI 时，建议使用 $\Phi 4$ 、 $\Phi 5$ LED灯珠，避免因受外力造成灯珠胶裂，且 AI 时注意力度。

6.cleaning(清洗)

Recommending using ethanol as solvent cleaning, do not use corrosive chemical liquid to clean LED, thus may damage epoxy resin of LED surface, even cause colloid cracks, meanwhile will produce corrosion rust on the LED tube feet.

推荐使用乙醇作为清洗的溶剂，不可用有腐蚀性的化学液体清洗 LED，这样可能会损坏 LED表面的环氧树脂，甚至引起胶体裂缝，同时还会对 LED管脚产生腐蚀生锈。