LCD MODULE SPECIFICATION

- Preliminary Specification
- Final Product Specification

MODEL NO. : IE-A-1110CH05R24-C0-1

CUSTOMER P/N: _____

ISSUED DATE : 2025.02.12

VERSION : _____

ATOPS:

Prepare by	Check by	Approve by

Customer :

Approve by	Notes

Table of Contents

1. General Specification	1
1.1. General Specification for LCM	1
2. Mechanical Drawing.....	2
3. PIN Descriptio	2
4. Absolute Maximum Rating.....	4
5. Electrical Characteristics.....	4
5.1. Operating Condition for LCD.....	4
5.2. Driving Condition for Backlight.....	5
6. Timing Chart for LCM	5
6.1. Timing Characteristics	5
6.2. DC Electrical Characteristics.....	5
7. Optical Characteristics.....	6
8. Reliability Test.....	9
9. Packing Specification.....	10
10. Precautions	10
10.1. Handling Precautions	10
10.2. Storage Precautions.....	11
10.3. Transportation Precautions	11

1. General Specification

1.1. General Specification for LCM

	Feature	Spec
Characteristics	Size	4.3" inch
	Resolution	480*RGB*272
	Interface	RGB
	Color Depth	16.7M
	Technology Type	TFT
	Pixel Pitch (mm)	66(H) x 198(V)
	Pixel Configuration	R.G.B. Vertical Stripe
	Display Mode	Normally black
	Surface Treatment(Polarizer)	Glare
	Viewing Direction	all
Mechanical Characteristics	Overall dimensions (W x H x D) (mm)	105.5(W)*67.2(H)*3.07
	Active Area(mm)	95.04(H)x 53.856(V)
	With /Without TP	Without TP
	Weight (g)	TBD
	LED Numbers	10 LEDS
Electronic	LCD Driver IC	ILI6485D

2. Mechanical Drawing

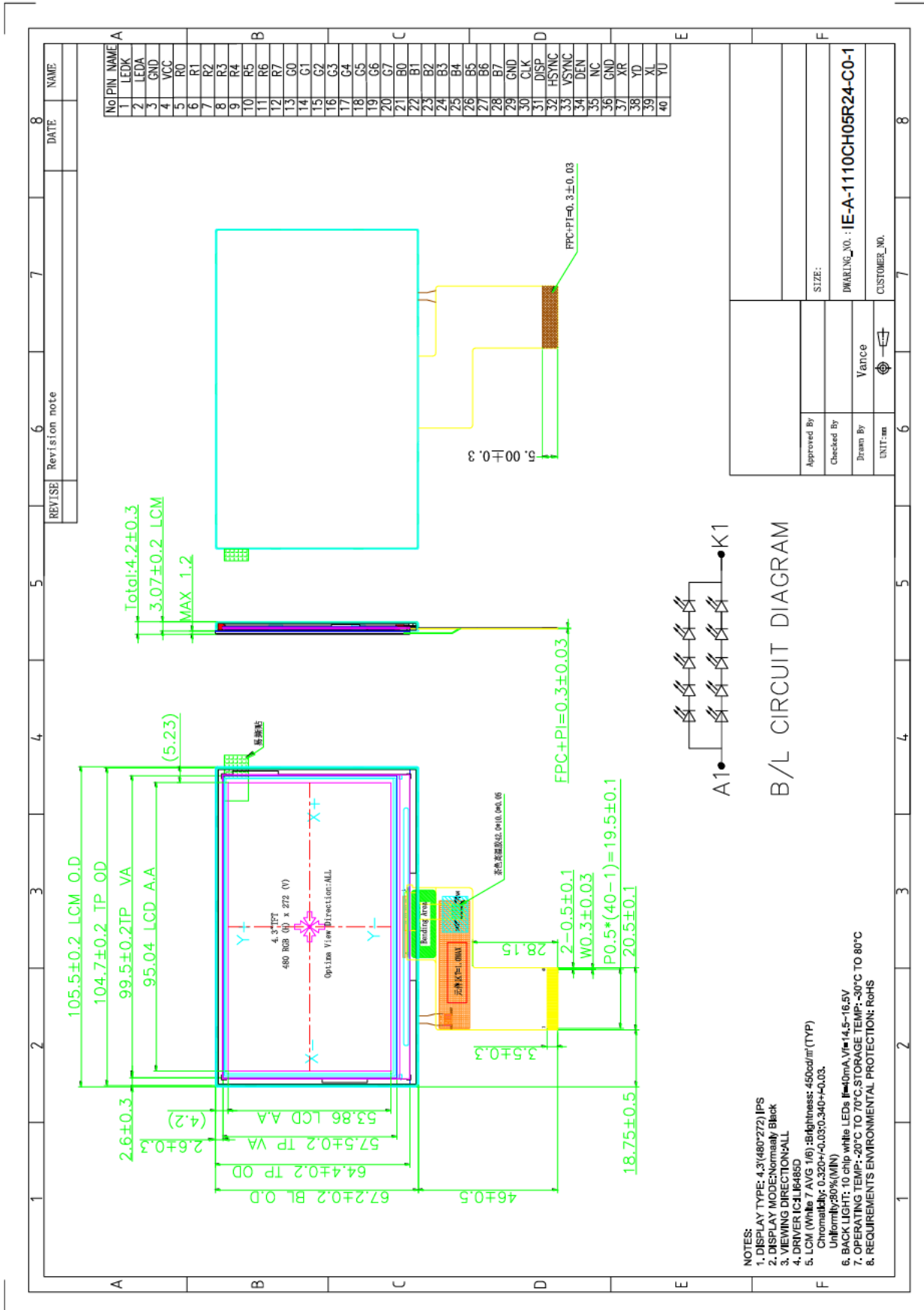

3.PIN Descriptio

Pin No.	Symbol	I/O	Function
1	LEDK	P	Power supply for LED.
2	LEDA	P	Power supply for LED.
3	GND	P	Ground.
4	VCC	P	Power supply for analog.
5-12	R0~R7	I	Red data.
13-20	G0~G7	I	Green data.
21-28	B0~B7	I	Blue data.
29	GND	P	Ground
30	CLK	I	Pixel clock signal in RGB interface
31	DISP	I	Display on/off
32	HSYNC	I	Horizontal sync. Signal in RGB interface
33	VSYNC	I	Vertical sync. Signal in RGB interface
34	DE	I	Data enable signal in RGB interface
35	NC	I	No Connect
36	GND	P	Ground
37	XR	I	Touch panel terminal (Right)
38	YD	I	Touch panel terminal (Down)
39	XL	I	Touch panel terminal (Light)
40	YU	I	Touch panel terminal (Up)

4. Absolute Maximum Rating

Ta = 25°C

Item	Symbol	Min	Max	Unit	Remark
Analog supply Voltage	VCI	-0.3	+4.6	V	-
Backlight Forward Current	IF	0	20	mA	For each serial LED
Operating Temperature	Top	-20	70	°C	-
Storage Temperature	Tst	-30	80	°C	-

5. Electrical Characteristics

5.1. Operating Condition for LCD

Ta = 25°C

Parameter	Symbol	MIN	TYP	MAX	Unit	Remark
Digital supply Voltage	VDDI	3	3.3	3.6	V	-
Input Signal Voltage	Low Level	VIL	VSSD	-	0.3*VDDI	RXIN0-,RXIN0+,RXIN1-,RXIN1+,RXIN2-,RXIN2+,SELB,RESET,STBYB,L/R,U/D,
	High Level	VIH	0.7*VDDI	-	VDDI	

5.2. Driving Condition for Backlight

Ta=25°C

Item	Symbol	Min	Typ	Max	Unit	Remark
Forward Current	IF	-	40	-	mA	Constant current driving
Forward Voltage	VF	14.5	15	16.5	V	
Backlight Power Consumption	-	-	600	-	mW	
Operating Life Time	-	-	30000	-	hrs	Note 3

Note 1: The LED driving condition is defined for total backlight consumption, and which depend on Forward Current setting.

Note 2: Forward Voltage is just for reference for one serial.

Note 3: The “Operating life time” is defined as the module brightness decrease to 50% original brightness at Ta=25°C and IF =40mA. The LED lifetime could be decreased if operating IF is larger than 40mA

6. Timing Chart for LCM

6.1. Timing Characteristics

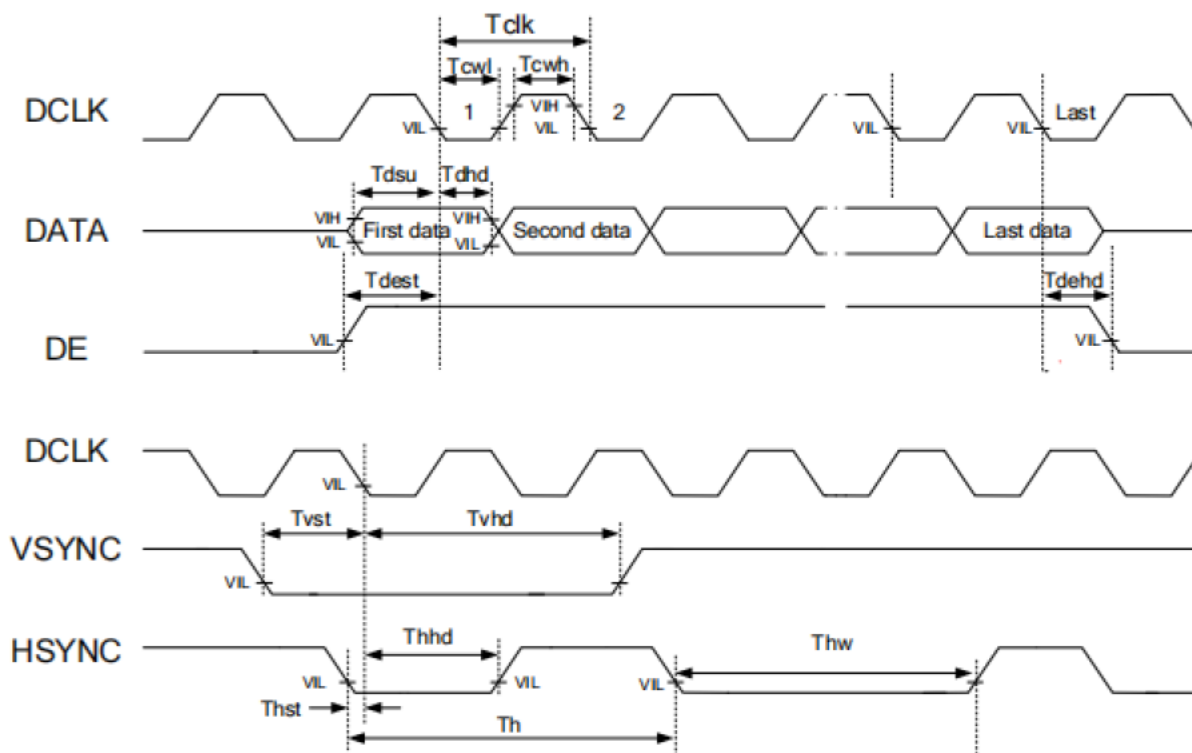

6.2. DC Electrical Characteristics

Item	Symbol	Values			Unit	Remark
		Min.	Typ.	Max.		
Analog Supply Voltage	VCI	3	3.3	3.6	V	-
Input High Voltage	V _{IH}	0.7VDDI	-	VDDI	V	Digital input pins
Input Low Voltage	V _{IL}	VSSD	-	0.3VDDI	V	Digital input pins
Output High Voltage	V _{oH}	VDDI-0.4	-	VDDI	V	Digital input pins
Output Low Voltage	V _{oL}	VSSD	-	VDDI+0.4	V	Digital input pins
(Panel+LSI) Power Consumption	Black Mode	-	20	-	mA	VCI=3.3V
	Sleeping Mode	-	-	0.05	mA	VCI=3.3V

7. Optical Characteristics

Item	Symbol	Condition	Min	Typ	Max	Unit	Remark
View Angle	θ_T	CR \geq 10	80	85	--	Degree	Note 2
	θ_B		80	85	--		
	θ_L		80	85	--		
	θ_R		80	85	--		
Contrast Ratio	CR	$\theta=0^\circ$	800	1000	--		Note1 Note3
Response Time	Tr	$\theta=0^\circ$	--	30	35	ms	Note1 Note4
	Tf						
Chromaticity (CIE1931)	White	x	-0.03	TBD	+0.03	-	Note1 Note5
		y		TBD			
	Red	x		TBD			
		y		TBD			
	Green	x		TBD			
		y		TBD			

	Blue	x			TBD			
		y			TBD			
Uniformity		U	-	75	80	--	%	Note1 Note6
NTSC ratio		-	-	--	--	--	%	Note 5
Luminance		L	-	-	450	--	cd/m2	Note1 Note7

Test Conditions:

1. IF=40 mA, and the ambient temperature is 25°C.
2. The test systems refer to Note 1 and Note 2.

Note 1: Definition of optical measurement system.

The optical characteristics should be measured in dark room. After 5 Minutes operation, the optical properties are measured at the center point of the LCD screen.

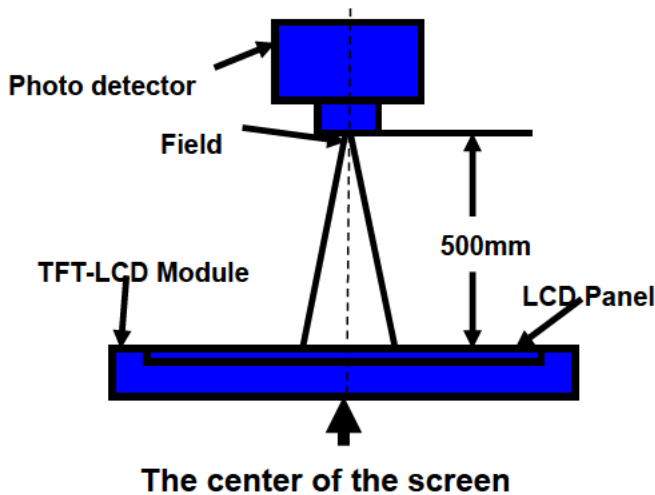

Item	Photo detector	Field
Contrast Ratio	BM-7A	1°
Luminance		
Chromaticity		
Lum Uniformity		

Note 2: Definition of viewing angle range and measurement system.

viewing angle is measured at the center point of the LCD by CONOSCOPE(ergo-80).

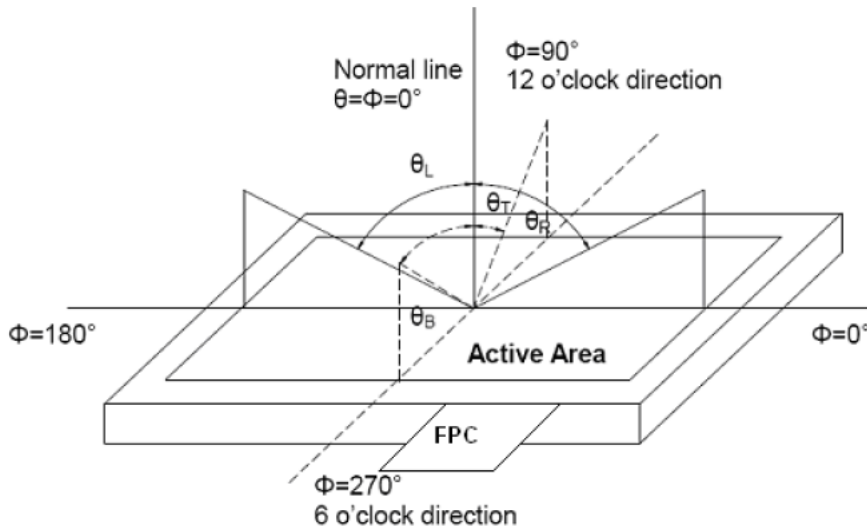

Note 3: Definition of contrast ratio

$$\text{Contrast ratio (CR)} = \frac{\text{Luminance measured when LCD is on the "White" state}}{\text{Luminance measured when LCD is on the "Black" state}}$$

“White” state: The state is that the LCD should drive by V_{white} .

“Black” state: The state is that the LCD should drive by V_{black} .

V_{white} : To be determined V_{black} : To be determined.

Note 4: Definition of Response time

The response time is defined as the LCD optical switching time interval between “White” state and “Black” state. Rise time (T_r) is the time between photo detector output intensity changed from 90% to 10%. And fall time (T_f) is the time between photo detector output intensity changed from 10% to 90%.

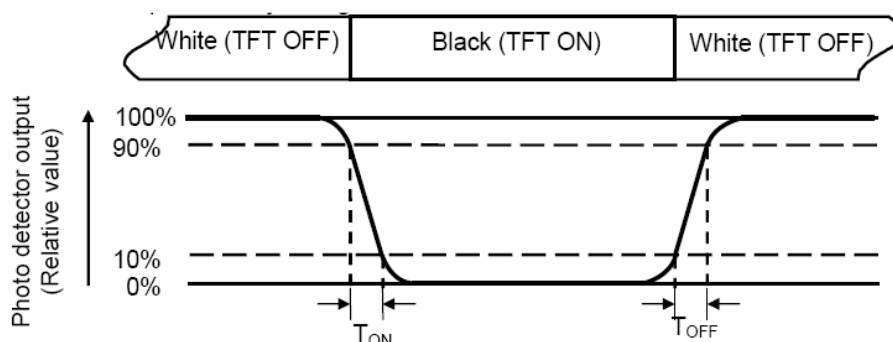

Note 5: Definition of color chromaticity (CIE1931)

Color coordinates measured at center point of LCD.

Note 6: Definition of Luminance Uniformity

Active area is divided into 9 measuring areas (Refer Fig. 2). Every measuring point is placed at the center of each measuring area.

$$\text{Luminance Uniformity (U)} = \frac{L_{\text{min}}}{L_{\text{max}}} \times 100\%$$

L-----Active area length W----- Active area width

Note 7: Definition of Luminance:

Measure the luminance of white state at center point.

L_{max} : The measured Maximum luminance of all measurement position.

L_{min} : The measured Minimum luminance of all measurement position.

$$\text{Luminance Uniformity (Yu)} = \frac{B_{min}}{B_{max}}$$

L-----Active area length W----- Active area width

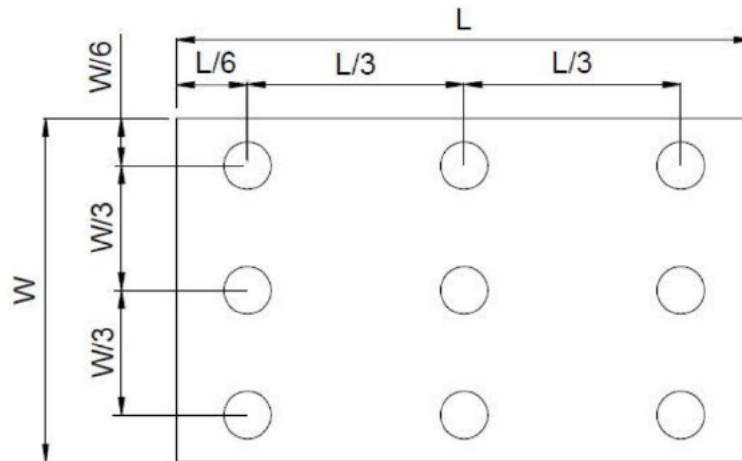

8. Reliability Test

Item	Test Conditions	Criterion
High Temperature Storage	Ta = 80°C 120hrs	A,B,C,D,E
Low Temperature Storage	Ta = -30°C 120hrs	A,B,C,D,E
High Temperature Operation	Ts = 70°C 120hrs	A,B,C,D,E
Low Temperature Operation	Ta = -20°C 120hrs	A,B,C,D,E
Operate at High Temperature and Humidity	+60°C, 90%RH 120hrs	A,B,C,D,E
Thermal Shock(non operation)	-20°C/30 min ~ +70°C/30 min for a total 5 cycles, Start with cold temperature and end with high temperature.	A,B,C,D,E
Vibration Test	Sweep:10Hz~55Hz~10Hz 2G 2 hours for each direction of X. Y. Z. (6 hours for total)	A,B,C,D,E
Package Vibration Test	Random Vibration : 0.015G*G/Hz from 5-200HZ, -6dB/Octave from 200-500HZ 2 hours for each direction of X. Y. Z. (6 hours for total)	A,B,C,D,E
Package Drop Test	Height:60 cm 1 corner, 3 edges, 6 surfaces	A,B,C,D,E

Electro Static Discharge	Contact= \pm 4KV, Air= \pm 8KV,(R=330R,C=150pF), 1 sec,9point,10times/point;	A,B,C,D,E
--------------------------	--	-----------

※Criterion:

A.LCM each function is OK.

B.LCM appearance inspection without abnormalities (Including scratch, damage, corrosion and serious deformation)

C.LCM brightness above the Min. value of Spec.

D. Luminance uniformity above the Min. value of Spec.

E. Color chromaticity within tolerance range

9. Packing Specification

TBD

10. Precautions

10.1. Handling Precautions

10.1.1. The display panel is made of glass. Do not subject it to a mechanical shock by dropping it from a high place, etc.

If the display panel is damaged and the liquid crystal substance inside it leaks out, be sure not to get any in your mouth, if the substance comes into contact with your skin or clothes, promptly wash it off using soap and water.

10.1.2. Do not apply excessive force to the display surface or the adjoining areas since this may cause the color tone to vary.

10.1.3. The polarizer covering the display surface of the LCD module is soft and easily scratched. Handle this polarizer carefully.

10.1.4. If the display surface is contaminated, breathe on the surface and gently wipe it with a soft dry cloth. If still not completely clear, moisten cloth with one of the following solvents:

- Isopropyl alcohol
- Ethyl alcohol

Solvents other than those mentioned above may damage the polarizer. Especially, do not use the following:

- Water
- Ketone
- Aromatic solvents

10.1.5. Do not attempt to disassemble the LCD Module.

10.1.6. If the logic circuit power is off, do not apply the input signals.

10.1.7. To prevent destruction of the elements by static electricity, be careful to maintain an optimum work environment.

10.1.8. Be sure to ground the body when handling the LCD Modules.

10.1.9. Tools required for assembly, such as soldering irons, must be properly ground.

10.1.10. To reduce the amount of static electricity generated, do not conduct assembly and other work under dry conditions.

10.1.11. The LCD Module is coated with a film to protect the display surface. Be care when peeling off this protective film since static electricity may be generated.

10.2. Storage Precautions

When storing the LCD modules, avoid exposure to direct sunlight or to the light of fluorescent lamps.

The LCD modules should be stored under the storage temperature range. If the LCD modules will be stored for a long time, the recommend condition is:

Temperature : 0°C ~ 40°C Relatively humidity: ≤80%

The LCD modules should be stored in the room without acid, alkali and harmful gas.

10.3. Transportation Precautions

The LCD modules should be no falling and violent shocking during transportation, and also should avoid excessive press, water, damp and sunshine.