

# **LED Display**

## Product Data Sheet

### IE-1PG-11001G

Spec No.:

Effective Date: Feb 25, 2015

## FEATURES

1 inch (25.4mm) Digit Height  
Low Power Requirement  
High Brightness and High Contrast  
Excellent Characters Appearance  
IC Compatible , Easy Assembly  
RoHS Compliant

## DESCRIPTION

This is a 1 inch (25.4mm) digit height single digit seven segment LED display. This device utilizes green LED chips, which are made from InGaN, and has a black face and white segments.

## DEVICE

Green	Description
IE-1PG-11001G	Common Anode, Right Hand Decimal
Total 15 Green LED Chips	

**PACKAGE DIMENSIONS**

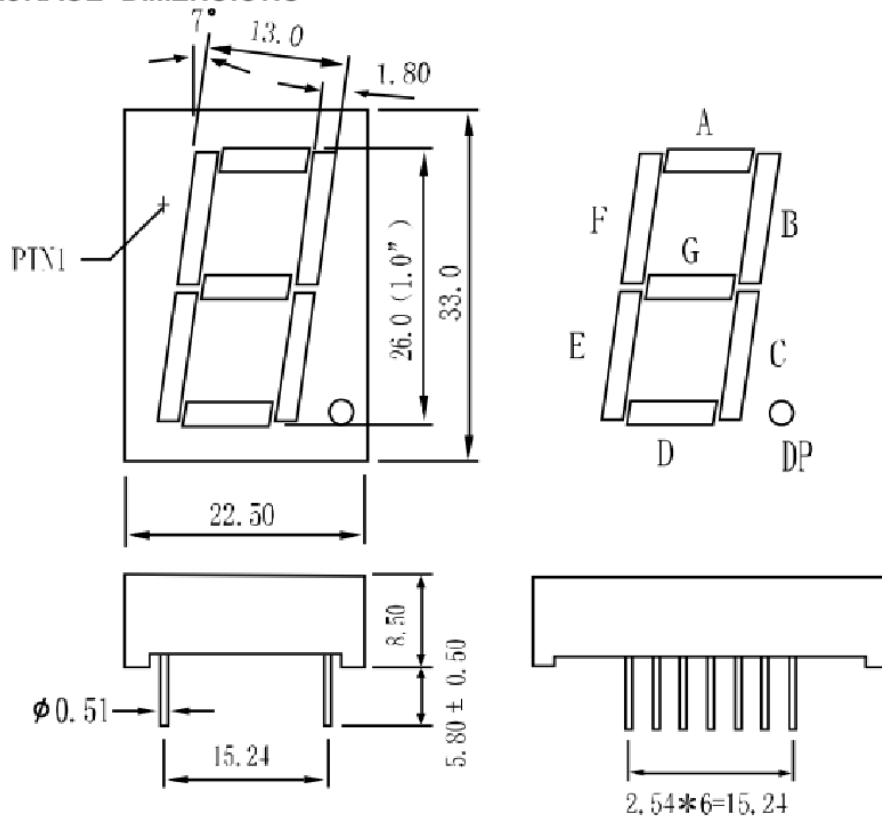

NOTES: All dimensions are in millimeters (inches). Tolerance is  $\pm 0.25$  (0.010") unless otherwise specified.

**INTERNAL CIRCUIT DIAGRAM**

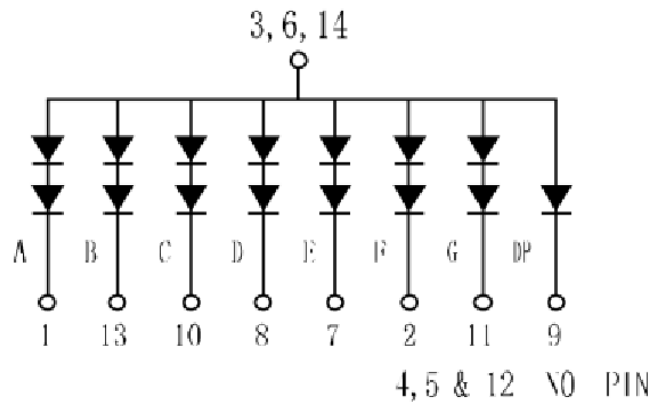

**PIN CONNECTION**

<b>PIN NO.</b>	<b>CONNECTION</b>
1	CATHODE A
2	CATHODE F
3	COMMON ANODE
4	NO PIN
5	NO PIN
6	COMMON ANODE
7	CATHODE E
8	CATHODE D
9	CATHODE DP
10	NO PIN
11	CATHODE G
12	NO PIN
13	CATHODE B
14	COMMON ANODE

**ABSOLUTE MAXIMUM RATINGS AT Ta=25°C**

PARAMETER	SYMBOL	InGaN GREEN	UNIT
Power Dissipation Per Segment	PAD	70	mw
Reverse Voltage Per Segment	VR	5	V
Continuous Forward Current Per Segment	IAF	20	mA
Peak Forward Current Per Segment(Duty-0.1,1KHz)	IPF	100	mA
Operating Temperature Range	TOPr	-20°C to 80°C	
Storage Temperature Range	Tstg	-30°C to 85°C	
Lead Soldering Temperature 260°C at 1.6mm From Body for 3 second			

**ELECTRICAL/OPTICAL CHARACTERISTICS AT Ta=25°C****InGaN GREEN**

PARAMETER	SYMBOL	TEST CONDITION	MIN	TYP	MAX	UNIT
Forward Voltage, Per Segment	VF	IF=20mA	3.0	3.2	3.5	V
Reverse Current, Per Segment	IR	VR=5V			50	μA
Peak Emission Wavelength	λp	IF=20mA	512.5		515	nm
Luminous Intensity Per Segment	IV	IF=20mA	200	250	300	mcd

TYPICAL ELECTRICAL / OPTICAL CHARACTERISTIC CURVES @ TA = 25°C

