

SPECIFICATION FOR APPROVAL

CUSTOMER NAME : _____

PART NO. : **IE-1WC-30011B-CA-NS**

ISSUE : **2025/6/13**

DATELOT NO : _____

Absolute Maximum Ratings

Parameter	Symbol	Maximum Rating	Unit
Power Dissipation	Pd	85	mW
Peak Forward Current	Ifp	60	mA
Continuous Forward Current	Ifm	20	mA
Reverse Voltage	VR	5	V
Operating Temperature Range		-40 → +80	°C
Storage Temperature Range	Tstg	-40 → +85	°C

*Lead Soldering Temperature: 260°C for 3 seconds

*For operation above 25°C. The Ifm Ifp & Pd must be derated. The Current derating is -0.36mA/°C for D drive and -0.86mA/°C for Pulse drive, the power dissipation is -0.75mW/°C. The product working current must not more than the 60% of the Ifm or Ifp according to the working temperature.

Optical-Electrical Characteristic

Parameter	Test Condition	Symbol	Min	Type	Max	Unit
Luminous Intensity	IF=10mA	Iv	70		100	Mcd
				-		
				-		
Forward Voltage	IF=10mA	VF	2.5		3.6	V
REVERSE Current	VR = 5V	IR	-		10	uA
Peak Wavelength	IF=10mA	λp	5500	-	7000	nm
				-		
				-		
				-		
Spectral Bandwidth	IF=10mA	Δλ	-	20	-	nm
View Angle	IF=10mA	2θ1/2	-	60	-	Deg.

Mechanical Outline:

Unspecified Tolerances is: $X \pm 0.2\text{mm}$

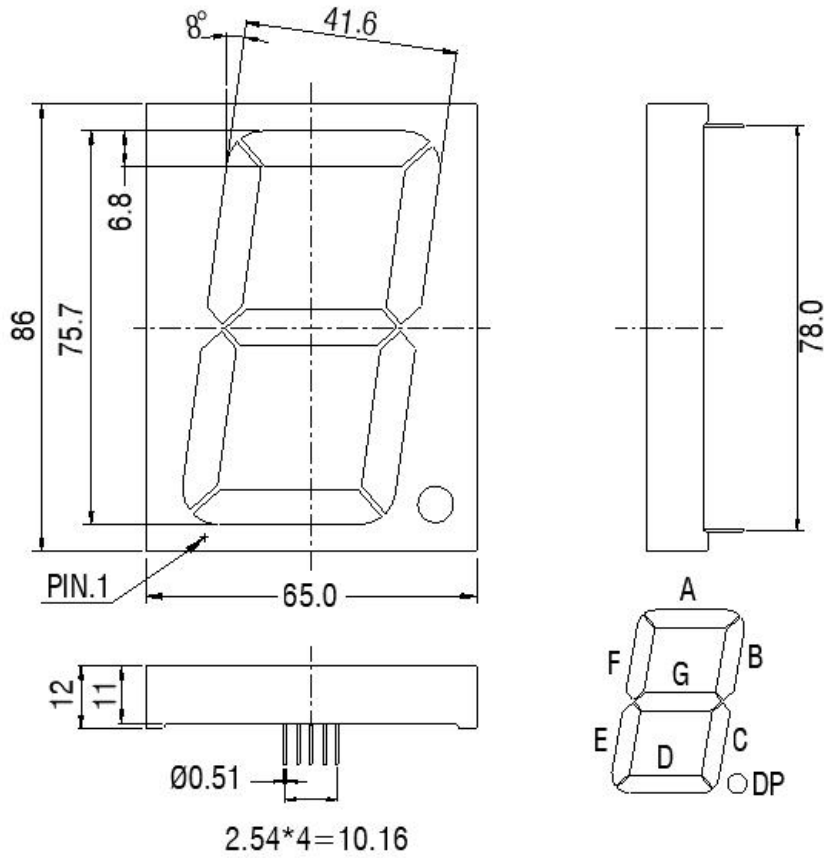

Circuit Diagram) :

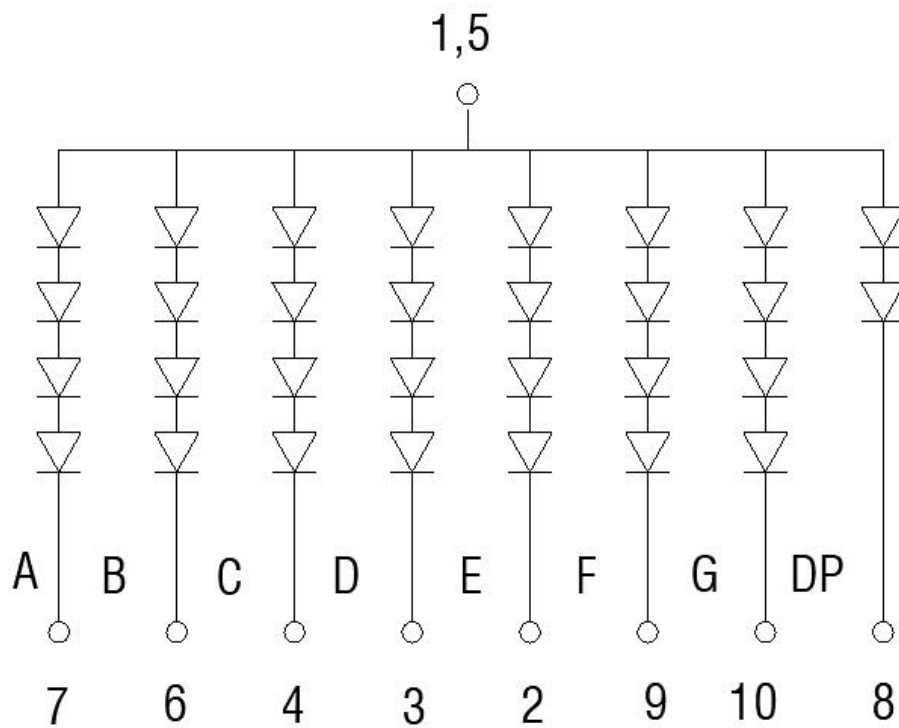

Storage & Soldering Condions:

- 1.Store with care. Storing the units in bad condition will cause the reflector sheet and decrease it's adhesive power. Storage the products under the condition :temperature ($25^{\circ}\text{C} \pm 10^{\circ}\text{C}$) and humidity ($65^{\circ}\text{C CRH} \pm 20^{\circ}\text{C CRH}$) our recommendation.
- 2.The Soldering Temperature is $260 \pm 5^{\circ}\text{C}$ and Soldering Time should be less than 3 sec, and soldering iron power should be less than 30W.
- 3.The soldering point should be farther than 1.6mm from boby.