

LCD MODULE SPECIFICATION

Model:	IE-A-1816BH07-00-1
Version:	V1.0
Date:	20191014

Preliminary Specification

Final Specification

Customer Confirmation

Approved by	Notes

Please return one of the copies of the specification with your signature to us within two weeks after you receive this document. If it is not returned, we will assume that you agree to the entire contents of this specification document.

VIEWE Confirmation

Prepared by	Reviewed by	Approved by

REVISION HISTORY

Revision	Date	Contents of Revision Change	Remark
V1.0	2019.10.14	Preliminary release	

TABLE of CONTENTS

1. GENERAL INFORMATION.....	4
1.1 Features.....	4
1.2 Mechanical Specification.....	4
2. ABSOLUTE MAXIMUM RATINGS.....	5
3. MECHANICAL DRAWING.....	6
4. I/O CONNECTION & BLOCK DIAGRAM.....	7
4.1 I/O Connection.....	7
4.2 Block Diagram.....	8
5. ELECTRICAL CHARACTERISTICS.....	9
5.1 TFT-LCD Panel Driving Section.....	9
5.2 Back Light Driving Section.....	9
5.3 Power On/Off Sequence.....	10
5.4 Timing Characteristics.....	11-13
5.5 Timing Diagram.....	13-13
6. OPTICAL CHARACTERISTICS.....	14-17
7. RELIABILITY.....	18
8. PACKAGE DRAWING.....	19

1. GENERAL INFORMATION

1.1 Features

- 1) Pixel Arrangement: RGB Vertical Stripe
- 2) Interface Mode: RGB24BIT
- 3) Driver IC: Source IC:ILI6122M-9G Gate IC:ILI5960-9G
- 4) Operation Temperature: -20~60°C
- 5) Storage Temperature: -30~90°C
- 6) Backlight Type: White LED
- 7) Display mode: Normally WHITE TN
- 8) Pixel Density: 133 PPI
- 9) LED life time: 30,000 Hours

1.2 Mechanical Specification

Item 项目	Specification 规格	Unit 单位	Remark 备注
Pixel Driving element	TN TFT	-	-
Screen Size	7.0	Inch	Diagonal
Resolution	800(W)*3(RGB)*480(H)	Dots	-
Interface	RGB	-	-
Module Power Consumption	2.0	Watt	Typ.
Active Area	154.08(W)*85.92(H)	mm	-
Pixel pitch (W*H)	0.1506(W)*0.1432(H)	mm	-
CTP_Module Size (W*H*D)	165.20(W)*100.20(H)*5.7(D)	mm	-
Luminance	700	cd/m ²	Typ.
Viewing Direction	12	O'clock	-
Display Color	16.7M	Colors	-

2. ABSOLUTE MAXIMUM RATINGS

Item	Symbol	Min.	Max.	Unit	Remark
Power supply1 voltage	VDD	-0.3	3.96	V	Note1
LED forward current	I _F	-0.001	30	mA	For each led,Note1
LED Reverse Voltage	V _R	-	5	V	For each led,Note1
Operating temperature	T _{op}	0	50	°C	Note1,2
Storage temperature	T _{st}	-20	60	°C	Note1,2
Humidity	H _{st}	10	90	%RH	Note1,3

(Ta=+25°C,GND=0V)

Note1:If the module exceeds the absolute maximum ratings, it may be damaged permanently. Also if the module operates with the absolute maximum ratings for a long time, the reliability may drop.

Note2: In case of temperature below 0°C ,the response time of liquid crystal (LC) becomes slower and the color of panel darker than normal one.

Note3: Temp. ≤ 60°C , 90% RH MAX.

Temp. > 60°C , Absolute humidity shall be less than 90% RH .

4. I/O CONNECTION & BLOCK DIAGRAM

4.1 I/O Connection

LCM	Symbol	I/O	Description
1	LEDK	P	Power supply for LED-
2	LEDA	P	Power supply for LED+
3	GND	P	Power Ground
4	VDD	P	Power Supply(3.3V typ.)
5-12	R0-R7	I	Red data input.
13-20	G0-G7	I	Green data input.
21-28	B0-B7	I	Blue data input.
29	GND	P	Power Ground
30	DCLK	I	Dot clock signal for DPI (RGB) interface operation.
31	DISP	I	Standby mode control. (Normally pull high) STBYB= "L" , enter standby mode for power saving. Timing
32	HS	I	Line synchronizing signal for DPI (RGB) interface operation
33	VS	I	Frame synchronizing signal for DPI (RGB) interface operation
34	DE	I	Data enable signal for DPI (RGB) interface operation
35	NC	-	NC
36	GND	P	Power Ground
37-40	NC	-	NC

I: Input; O: Output; P: Power

4.2 Block Diagram

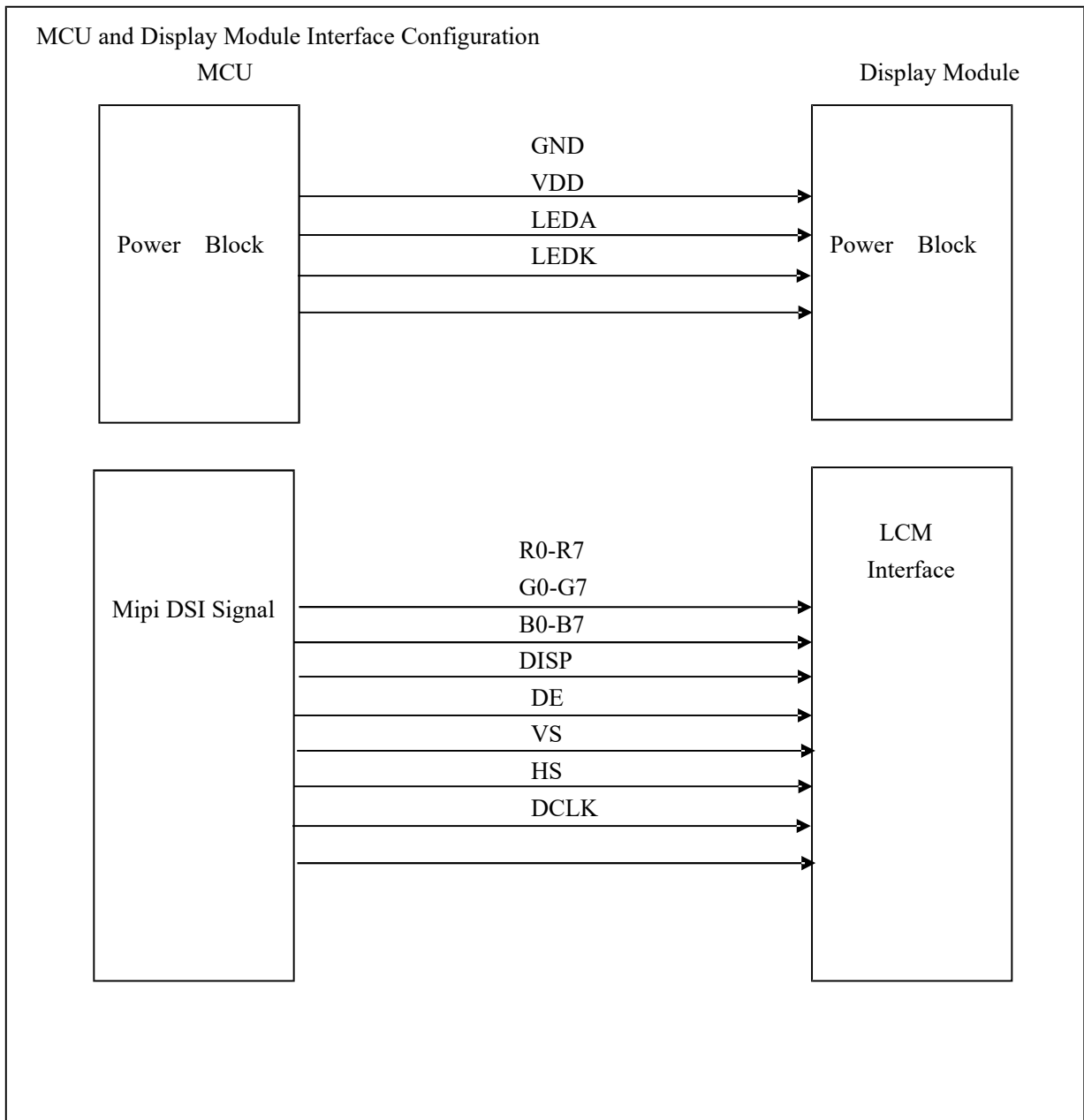

5. ELECTRICAL CHARACTERISTICS

5.1 TFT-LCD Panel Driving Section

Item	Symbol	Min.	Typ.	Max.	Unit	Remark
Power Supply1 Voltage	VDD	2.7	3.3	3.6	V	-
Power Supply Current	I _{VDD}	-	30	-	mA	Note1
Logic Input High Voltage	V _{IH}	0.7VDD	-	VDD	V	-
Logic Input Low Voltage	V _{IL}	0	-	0.3VDD	V	-
Panel Power Consumption	P _{VDD}	-	0.099	-	Watt	Note1
Module Power Consumption	P _{LCM}	-	2.0	-	Watt	Note1,2

Note1: Measurement Conditions (Video Mode): Full Screen Red Pattern, VDD=2.8V, 60Hz Refresh.

Note2: $P_{LCM} = P_{VDD} + P_{BL}$, About P_{BL} information, inference to 5.2 Back Light Driving Section.

5.2 Back Light Driving Section

Item	Symbol	Min.	Typ.	Max.	Unit单	Remark
Forward Voltage	V _F	-	9.6	-	V	Note1
Forward Current	I _F	-	200	-	mA	Note1
Backlight Power consumption	P _{BL}	-	1.92	-	Watt	Note1
LED life time	-	30000	-	-	Hours	Note2
LED Quantity			30		PCS	

Note1: The LED driving condition is defined for each LED module (3 LED Serial, 10 LED Parallel). For each LED : I_F=20mA, V_F=3.2V(Typ.), T_a=25°C .

Note2: The “LED life time” is defined as the module brightness decrease to 50% of original brightness at I_{LED}=20mA(Per Led). The LED life time could be decreased if operating I_{LED} is larger than 20mA.

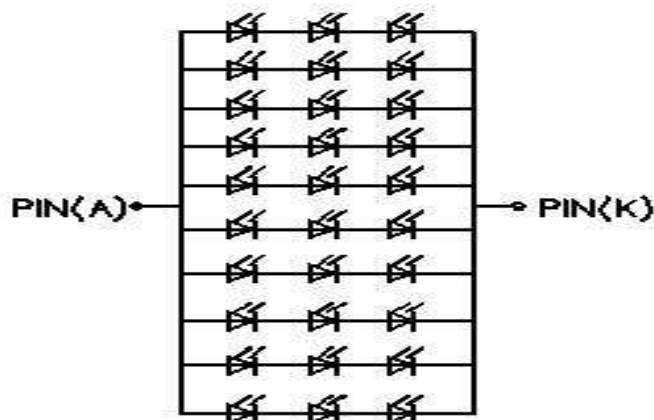

5.3 Power On/Off Sequence

5.3.1 Power On/Off Sequence

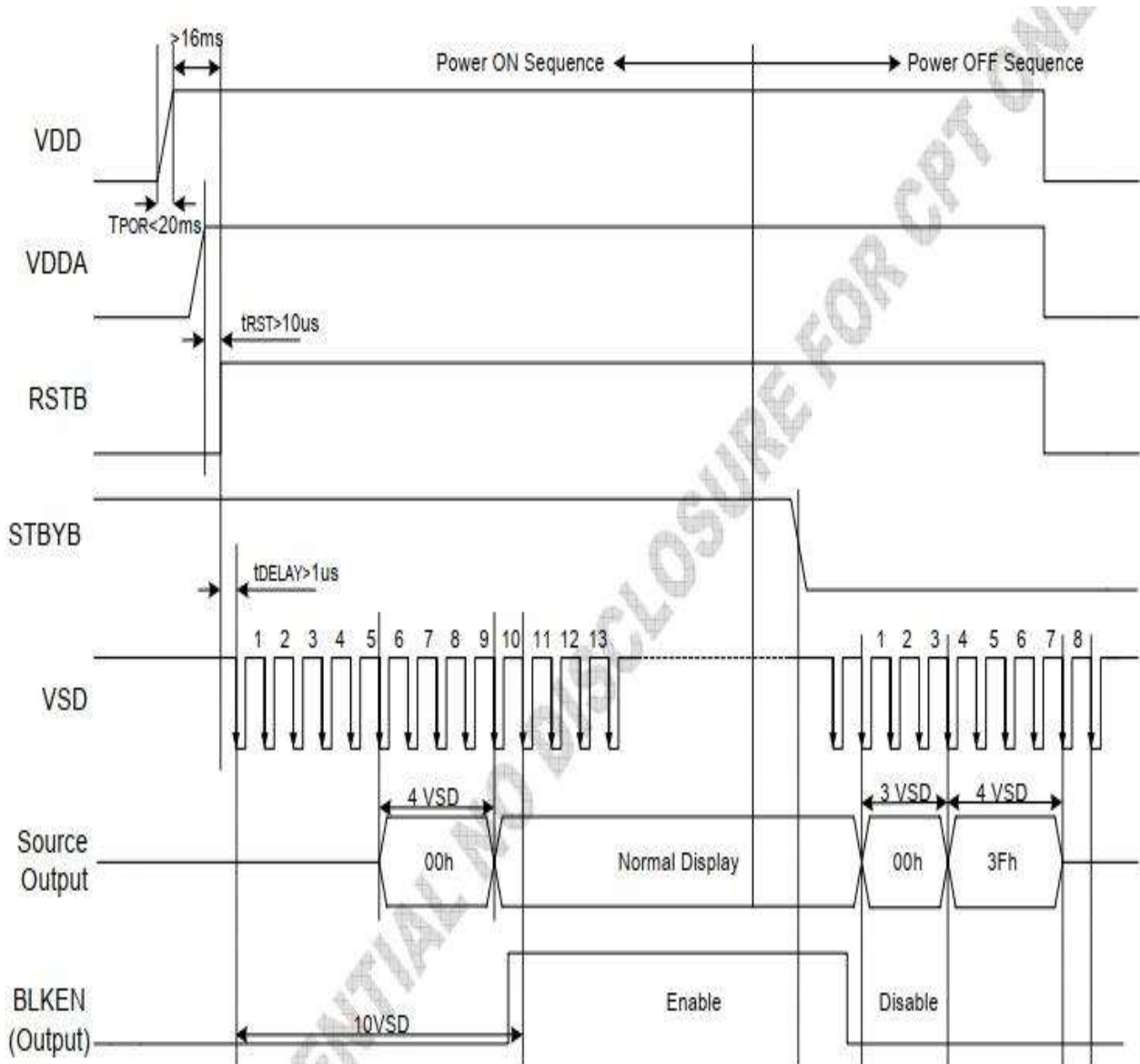

5.4 Timing Characteristics

5.4.1 AC Characteristics

DE Mode (MODE='1')

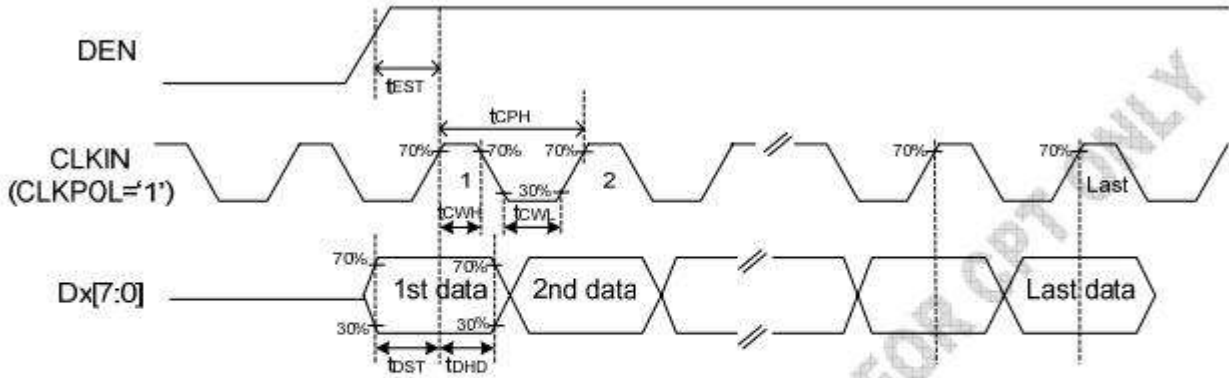

SYNC Mode (MODE='0')

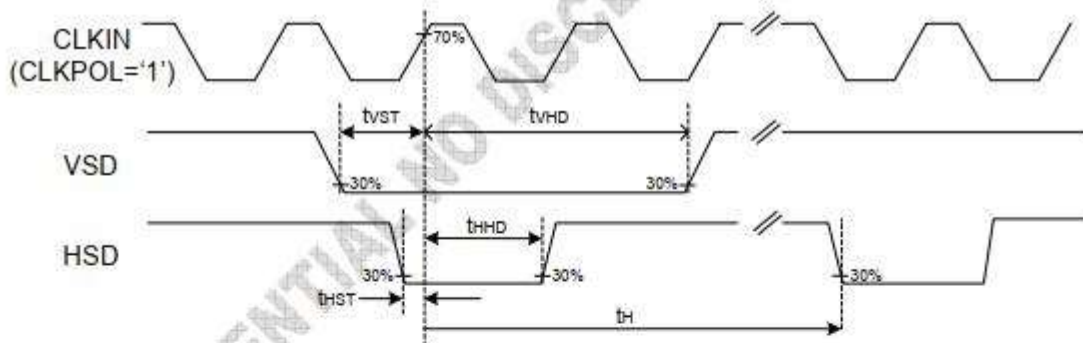

Source Output timing Diagram (Cascade)

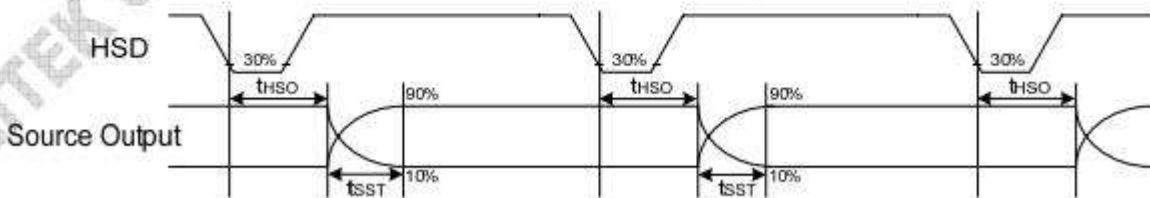

Vertical Timing Diagram of SYNC Mode (Dual Gate)

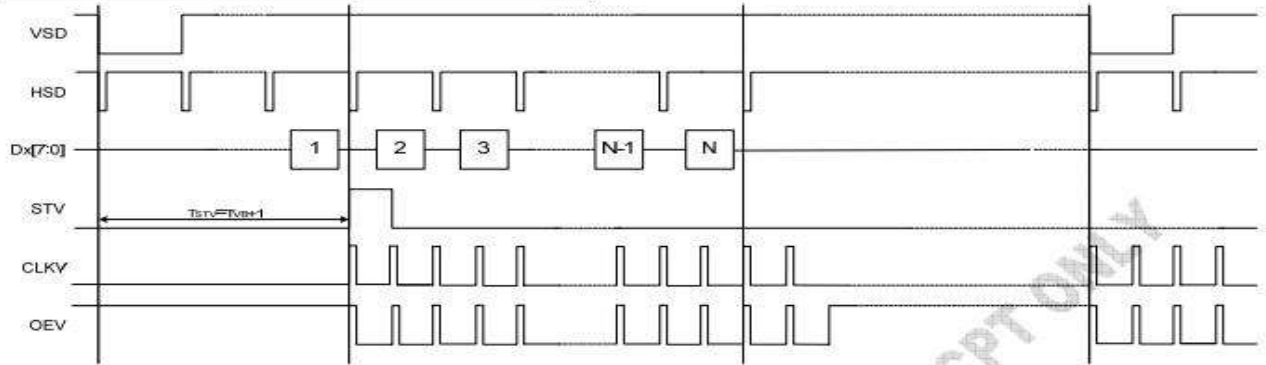

Vertical Timing Diagram of DE Mode (Dual Gate)

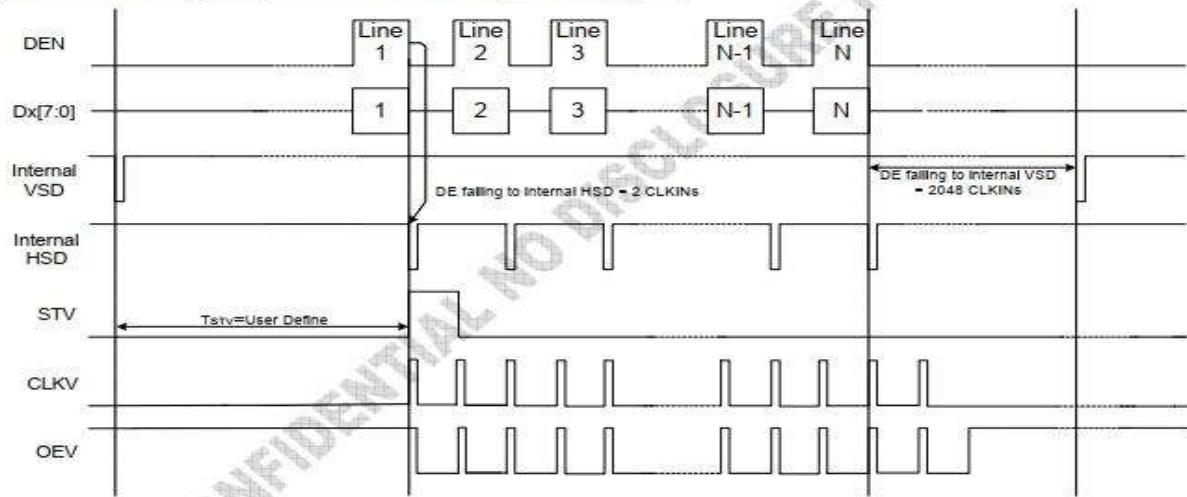

Gate Output Timing Diagram (Dual Gate)

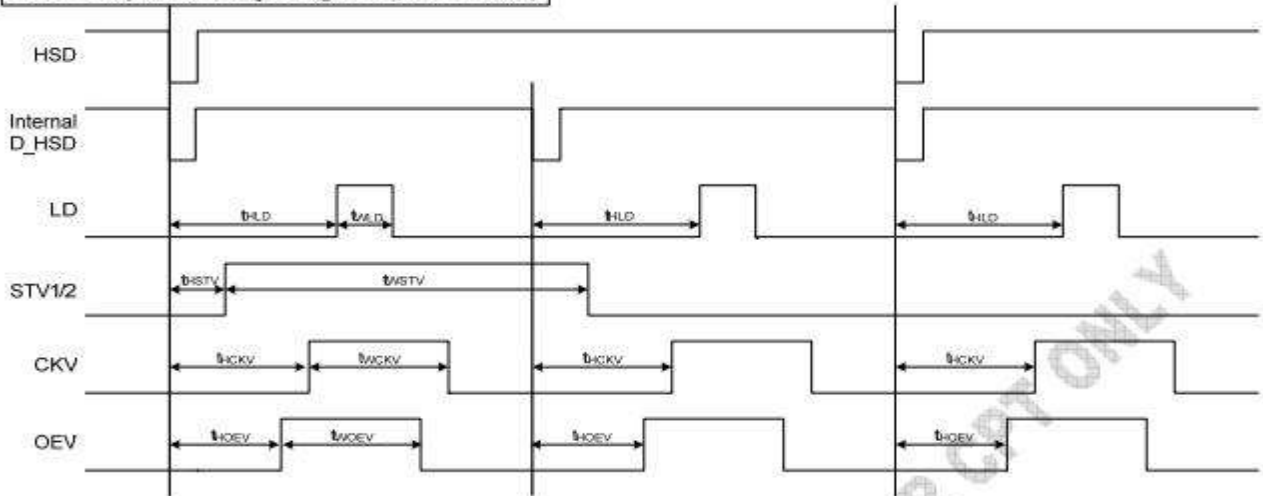

Parameter	Symbol	Spec			Unit	Conditions
		Min.	Typ.	Max.		
VDD Power ON slew rate	tPOR	--	--	20	ms	0V ~ 0.9VDD
RSTB pulse width	trST	10	--	--	us	CLKIN=50MHz
CLKIN cycle time	tCPH	20	--	--	ns	
CLKIN pulse duty	tCWH	40	50	60	%	
VSD setup time	tVST	8	--	--	ns	
VSD hold time	tVHD	8	--	--	ns	
HSD setup time	tHST	8	--	--	ns	
HSD hold time	tHHD	8	--	--	ns	
Data setup time	tDST	8	--	--	ns	D0[7:0], D1[7:0], D2[7:0] to CLKIN
Data hold time	tDHD	8	--	--	ns	D0[7:0], D1[7:0], D2[7:0] to CLKIN
DE setup time	tEST	8	--	--	ns	
DE hold time	tEHD	8	--	--	ns	
Output stable time	tSST	--	--	6	us	10% to 90% target voltage. CL=120pF, R=10KΩ
CLKIN frequency	fCLK	--	40	50	MHz	VDD=3.0 ~ 3.6V
CLKIN cycle time	tCLK	20	25	--	ns	
CLKIN pulse duty	tCWH	40	50	60	%	TCLK
Time from HSD to Source output	tHSO	--	20	--	CLKIN	
Time from HSD to LD	tHLD	--	20	--	CLKIN	Note (2)
Time from HSD to STV	tHSTV	--	2	--	CLKIN	
Time from HSD to CKV	tHCKV	--	20	--	CLKIN	
Time from HSD to OEV	tHOEV	--	4	--	CLKIN	
LD pulse width	tLWD	--	10	--	CLKIN	Note (2)
CKV pulse width	tWCKV	--	66	--	CLKIN	
OEV pulse width	tWCEV	--	74	--	CLKIN	

Note: (1) VDD=3.0 ~ 3.6V, VDDA=6.5~13.5V, DGND=AGND=0V, Ta=-20~+85°C

(2) The contents of the data register are transferred to the latch circuit at the rising edge of LD. Then the gray scale voltage is output from the device at the falling edge of LD.

(3) Output loading condition :

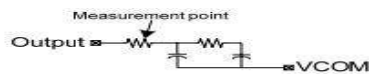

5.5 Timing Diagram

5.5.1 Horizontal Timings

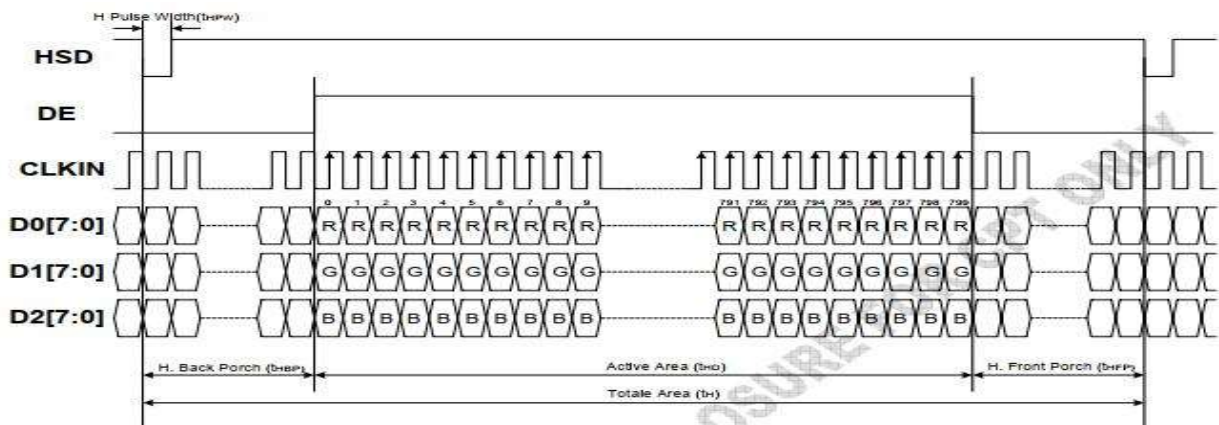

5.5.2 Vertical Timings

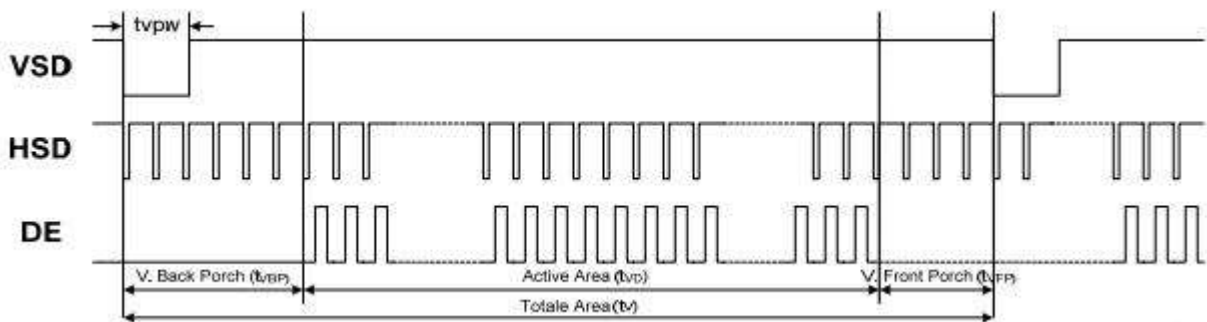

5.5.3 Timing Parameters

Parameter	Symbol	Value			Unit
		Min.	Typ.	MAX.	
Bit rate per lane	BRPHY	80	-	1000	Mbps
Active pixel per line	HACT	-	800	-	Pixels
Horizontal back porch	tHBP	-	46	-	DCLK
Horizontal sync active	tHSA	-	40	-	DCLK
Horizontal front porch	tHFP	-	21	-	DCLK
Active pixel per frame	VACT	-	480	-	H
Vertical back porch	tVBP	-	23	-	H
Vertical sync active	tVSA	-	10	-	H
Vertical front porch	tVFP	-	22	-	H

6. OPTICAL CHARACTERISTICS

Parameter	Symbol	Condition	Min.	Typ.	Max.	Unit	Remark
Contrast Ratio	C/R	$\theta = 0^\circ$	500	800	-	-	Note(4)
NTSC Ratio	S	$\theta = 0^\circ$	25	50	-	%	Note(7)
Luminance	L	$\theta = 0^\circ$	-	700	-	cd/m ²	Note(5)
Luminance uniformity	U _w	$\theta = 0^\circ$	70	80	-	%	Note(3)
Response Time	T _{R+} T _F	25 °C	-	25	35	ms	Note(2)
Color Coordination	W _X	$\theta = 0^\circ$ (Center) Normal viewing angle B/L On	-0.03	0.310	+0.03	NTSC (x,y)	Note(6)
	W _Y			0.330			
	R _X			TBD			
	R _Y			TBD			
	G _X			TBD			
	G _Y			TBD			
	B _X			TBD			

	B _Y			TBD			
Viewing Angle	θ_L	C/R>10	-	70	-	Degree	Note(1)
	θ_R		-	70	-		
	θ_U		-	60	-		
	θ_D		-	70	-		

Test Conditions:

1. VDD=2.8V, I_F=40mA (Backlight current), the ambient temperature is +25°C.
2. The test systems refer to Note 8.

Note1: Definition of Viewing Angle: The viewing angle range that the CR>10

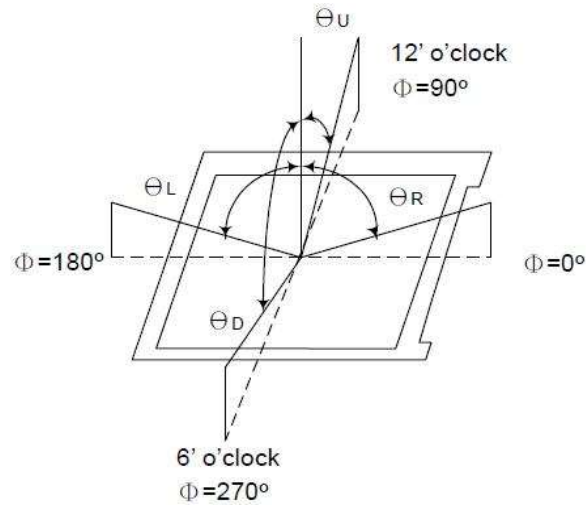

Note2: Definition of Response time: Sum of T_R and T_F

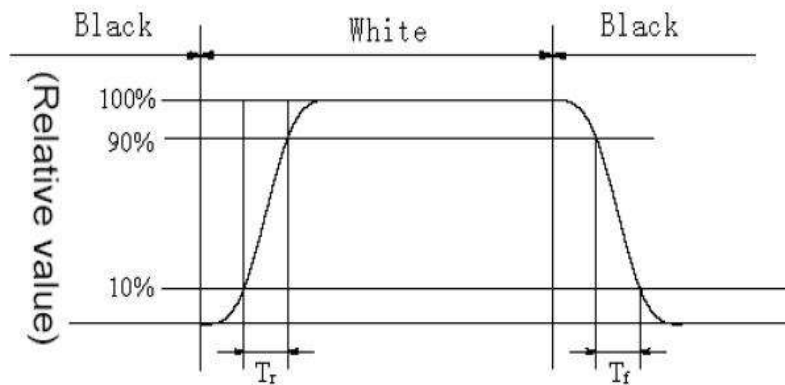

Note 3: Definition of Luminance Uniformity: Active area is divided into 9 measuring areas, every measuring point is placed at the center of each measuring area.

$$\text{Luminance Uniformity} = \frac{\text{Min Luminance of white among 9-points}}{\text{Max Luminance of white among 9-points}} \times 100\%$$

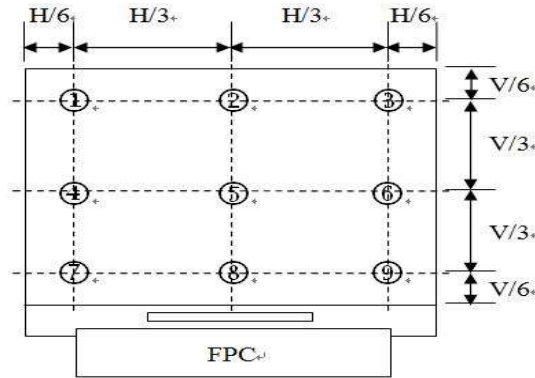

Note 4: Definition of Contrast Ratio (CR): measured at the center point of panel

$$\text{Contrast ratio (CR)} = \frac{\text{Luminance measured when LCD on the "White" state}}{\text{Luminance measured when LCD on the "Black" state}}$$

Note 5

Luminance: Center Luminance of white is defined as luminance values of 1 point average across the LCD surface.

Definition of

Note 6: Definition of Color Chromaticity (CIE 1931)

Color coordinates of white & red, green, blue measured at center point of LCD.

Note 7: Definition of NTSC ratio:

$$\text{NTSC ratio} = \frac{\text{Area of RGB triangle}}{\text{Area of NTSC triangle}}$$

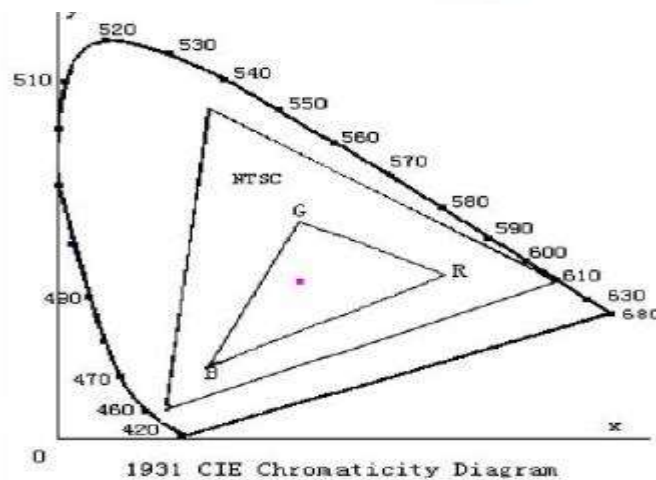

Note 8: Definition of optical measurement system.

The optical characteristics should be measured in dark room. After 5 minutes operation, the optical properties are measured at the center point of the LCD screen. (Response time is measured by Photo detector TOPCON BM-7, Field of view: 1°/Height: 500mm.)

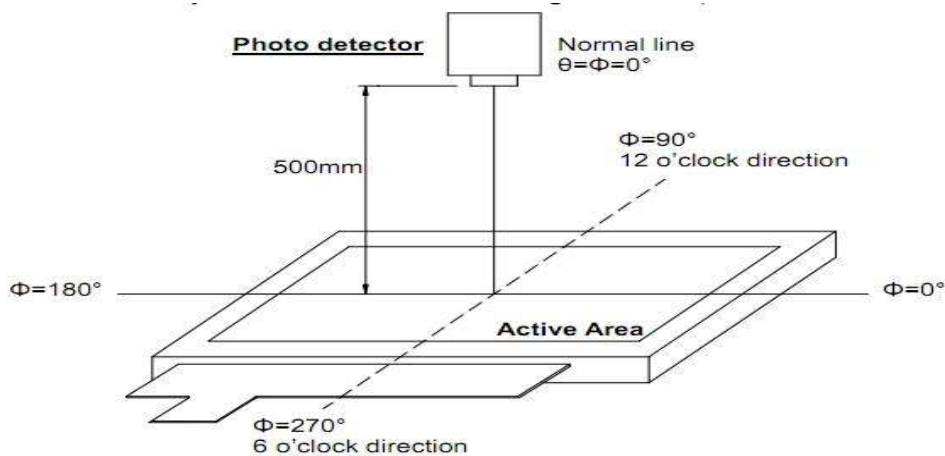

7. RELIABILITY

Item	Test Condition	Remark
High Temperature Storage	Ta =+60°C / 96Hours	Note1,2,3
Low Temperature Storage	Ta =-20°C / 96Hours	Note1,2,3
High Temperature Operating	Ta =+50°C / 96Hours	Note1,2,3
Low Temperature Operating	Ta =0°C / 96Hours	Note1,2,3
Temperature Cycle storage Test	-20°C/30min ⇌+60°C /30min for 30cycles,Transfer time less than 5min	Note2,3
Thermal humidity storage Test	60°C x 90%RH / 96Hours	Note2,3
Package Vibration Test	Frequency: 10Hz~55Hz,Amplitude:1.5mm, 1 hrs for each direction of X, Y, Z	Note2

Inspection after Test:

Note1:Ta is the ambient temperature of samples.

Note 2: In the standard condition, there shall be no practical problem that may affect the display function. After the reliability test, the product only guarantees operation, but doesn't guarantee all the cosmetic specification.

Note 3: Before cosmetic and function tests , the product must have enough recovery time, at least 2 hours at room temperature.