

Specification

P/N (CUSTOMER P/N): IE-1B-10563B
(DATE): 2011 12 30

Type :
IE-1B-10563B



■ 产品特征 FEATURES:

- 高可靠性和高稳定性

High intensity and reliability

- 高品质、和低功耗、低成本

High quality, Low power requirement and low cost

- IC 易兼容、易装配

IC compatible , Easy assembly

- 符合 RoHS 指令要求

Meet RoHS EU Directive

- 静电承受能力 200V

ESD 200V

■ 产品描述 DESCRIPTION:

- 0.56 英寸单位数码管

0.56 Inch Single Digits Display

- 极性共阳

Common Anode

- 黑面, 白胶

Black face, white segment

- 发光颜色

Lighting Color:

1、蓝色 BLUE

2、

3、

4、

5、

- 晶片材质

1、InGaN

2、

3、

4、

5、

Type :
IE-1B-10563B



■ 产品最大绝对参数值 (Ta: 25℃) ABSOLUTE MAXIMUM RATINGS AT T_a=25℃:

PARAMETER 项目	SYMBOL 符号	BLUE 蓝色	UNIT 单位
Power Dissipation Per Segment 功耗	PAD	100	mw
Reverse Voltage Per Segment 反向耐压	VR	5	V
Continuous Forward Current Per Segment 最大使用直流	IAF	30	mA
Peak Forward Current Per Segment(Duty-0.1,1KHz) 最大峰值直流	IPF	100	mA
Operating Temperature Range 工作温度	TOPr	-20℃ to 80℃	
Storage Temperature Range 贮藏温度	Tstg	-30℃ to 85℃	
Lead Soldering Temperature 260℃ at 1.6mm From Body for 3 second 焊接温度 260℃/3秒 距离胶体 1.6mm 以上			

■ 产品光电参数值 (Ta: 25℃) ELECTRICAL/OPTICAL CHARACTERISTICS AT Ta=25℃:

PARAMETER 项目	SYMBOL 符号	TEST CONDITION 测试条件	Color 颜色	MIN 最小值	TYP 标准值	MAX 最大值	UNIT 单位
Forward Voltage ,Per Segment 正向压降	VF	IF=20mA	蓝色 BLUE	3	3.2	3.5	V
Reverse Current , Per Segment 反向漏电流	IR	VR=5V	蓝色 BLUE			50	μA
Peak Emission Wavelength 峰值波长	λp	IF=20mA	蓝色 BLUE	460	462.5	465	nm
Luminous Intensity Per Segment 法向光强	IV	IF=20mA	蓝色 BLUE	70	80	100	mcd

Type :
IE-1B-10563B

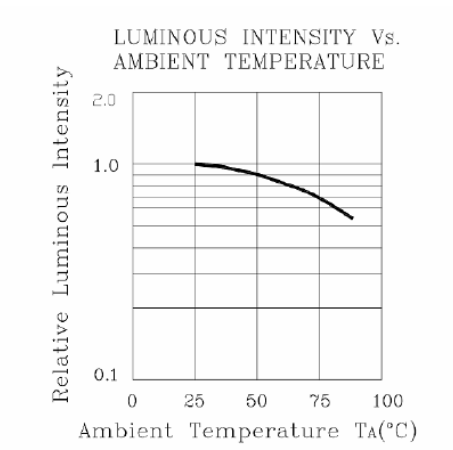
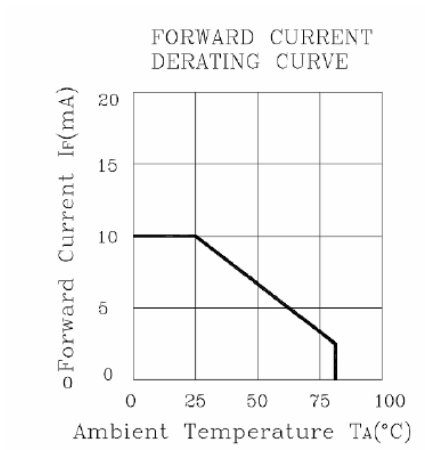
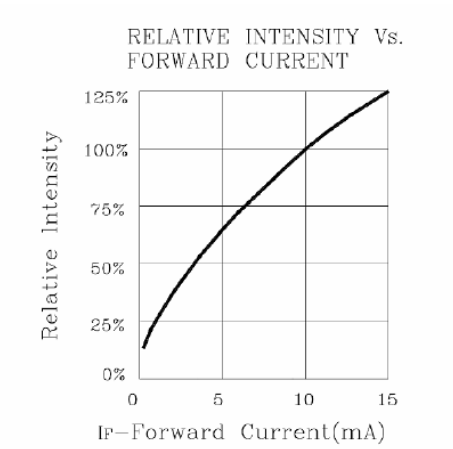
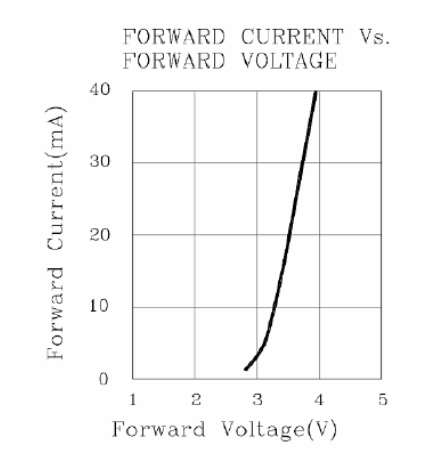
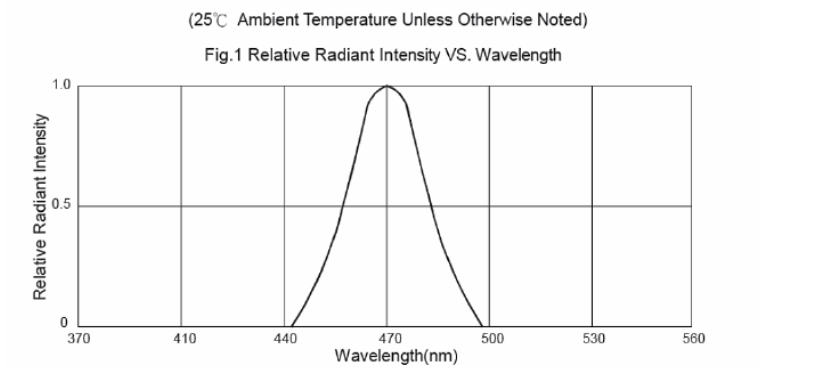

Type :
IE-1B-10563B

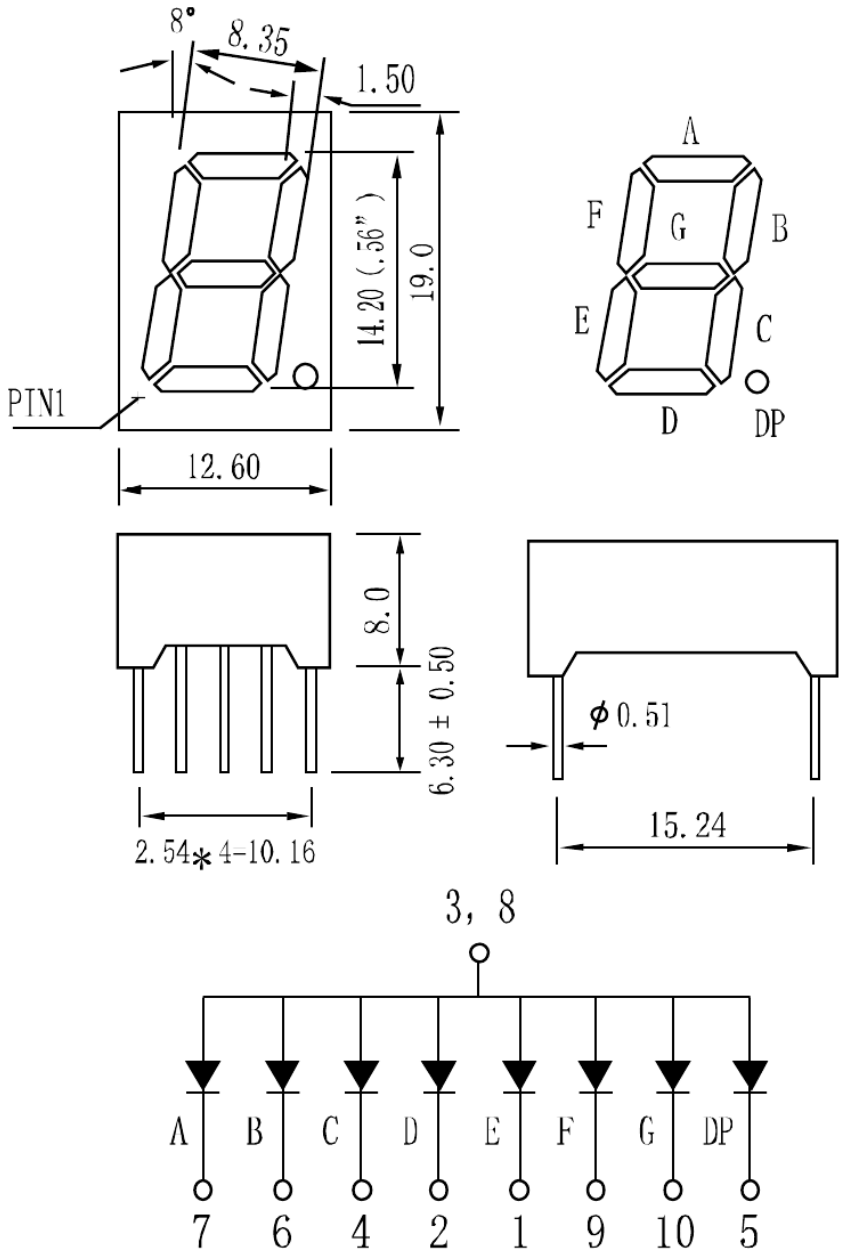

NOTES : 1. All dimensions are in millimeters. (inches)

2. Tolerance is ± 0.25(0.010") unless otherwise specified.