

SPECIFICATION

| | | | |
|--------------|--|------------|------------------------------|
| Customer | | Product | TOP LED |
| | | Type | IE-3535RGB-HB-BBO-ASH |
| Customer No. | | Version NO | A1 |

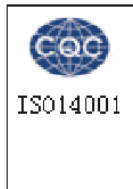

| Research & Development Center | | | Customer (Stamp) |
|-------------------------------|-------|---------|------------------|
| DRAW | CHECK | APPROVE | CONFIRM |
| | | | |
| (Release Date): 2016-6-20 | | | |

Technical Data Sheet

These products are full-color SMD components with black frame and white refractor, high contrast, which are featured by multiple waterproof performance, good reliability, long lifespan and wide viewing angle. They are designed for outdoor display and decoration applications.



| | | | | |
|------------------|--------------------|--|-------|-------|
| Features: | Material: | Red | Green | Blue |
| | | AlGaInP | InGaN | InGaN |
| | Encapsulation: | Epoxy Resin | | |
| | Soldering methods: | Pb-Free reflow soldering | | |
| | | High Luminous Intensity, Low Power Dissipation, good Reliability and Long Life | | |
| | | Complied With ROHS Directive | | |

Catalogue

| | |
|--|-----------|
| Electrical Characteristics | 2 |
| Typical Characteristic Curves | 3 |
| Reliability Test Items and Conditions | 4 |
| Outline Dimensions | 5 |
| Packaging | 6 |
| Guideline for Soldering | 8 |
| Precautions | 10 |

* The specifications of the product may be modified for improvement without notice.

Electro-Optical Characteristics

✧ Absolute Maximum Ratings (Temperature=25°C)

| Parameter | Symbol | Rating | Unit |
|-------------------------|-----------|------------|------|
| Forward Current | I_F | 25 | mA |
| Pulse Forward Current * | I_{FP} | 100 | mA |
| Reverse Voltage | V_R | 5 | V |
| Operating Temperature | T_{OPR} | -30 ~ +85 | °C |
| Storage Temperature | T_{stg} | -40 ~ +100 | °C |
| Power Dissipation | Red | P_D | 60 |
| | Green | | 90 |
| | Blue | | 90 |
| | | | mW |

* Note: Pulse Width $\leq 0.1ms$, Duty $\leq 1/10$

✧ Electro-Optical Characteristics (Temperature=25°C)

| Parameter | Symbol | Condition | Color | Min. | Typ. | Max. | Unit |
|------------------------------|-----------------|------------|-------|------|------|------|---------|
| Reverse Current | I_R | $V_R=5V$ | Red | | | 10 | μA |
| | | | Green | | | 10 | |
| | | | Blue | | | 10 | |
| Forward Voltage | V_F | $I_F=15mA$ | Red | 1.8 | 2.0 | 2.6 | V |
| | | $I_F=8mA$ | Green | 2.4 | 3.0 | 3.2 | |
| | | $I_F=5mA$ | Blue | 2.4 | 3.0 | 3.2 | |
| Dominant Wavelength | λ_D | $I_F=15mA$ | Red | 620 | 622 | 626 | nm |
| | | $I_F=8mA$ | Green | 520 | 525 | 530 | |
| | | $I_F=5mA$ | Blue | 468 | 470 | 480 | |
| Spectrum Radiation Bandwidth | $\Delta\lambda$ | $I_F=15mA$ | Red | | | 24 | nm |
| | | $I_F=8mA$ | Green | | | 38 | |
| | | $I_F=5mA$ | Blue | | | 28 | |
| Luminous Intensity | I_V | $I_F=15mA$ | Red | 350 | 500 | 700 | mcd |
| | | $I_F=8mA$ | Green | 600 | 830 | 1150 | |
| | | $I_F=5mA$ | Blue | 90 | 120 | 160 | |
| View Angle | 201/2 | | | | 110 | | deg. |

* Note: The parameters above only for your reference. In case of any discrepancy, please adhere to the label of our actual products. All parameters tested by the standard testing system .

Typical Characteristics Curves

Volt-Ampere Characteristics

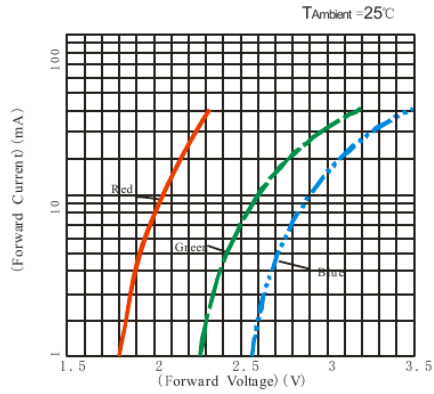

Relative Luminous Intensity VS Forward Current

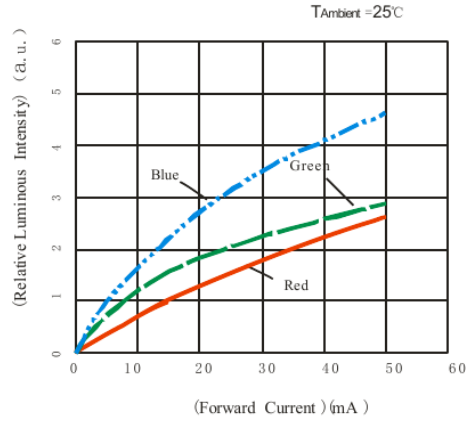

Forward Current Derating Curve

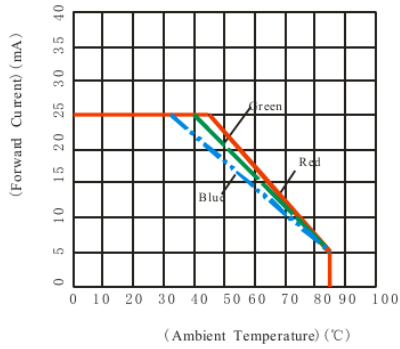

Luminous Intensity VS Ambient Temperature

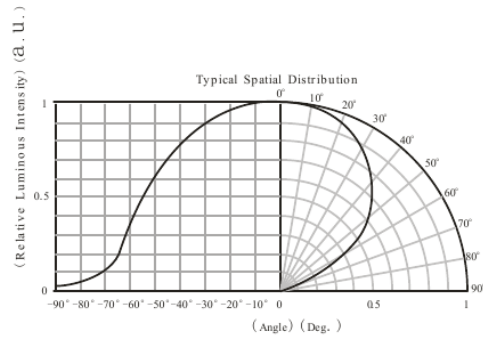
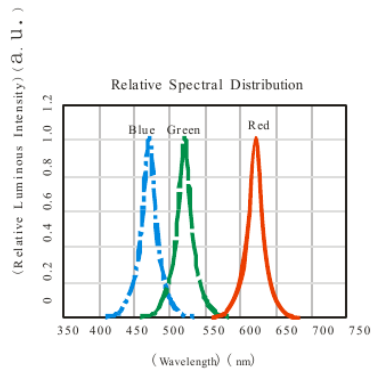
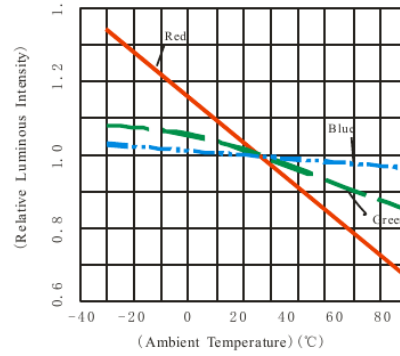

Reliability Test Items And Conditions

| Test Items | Reference | Test Conditions | Time | Quantity | Criterion |
|--|------------------------|--|-------------------|----------|-----------|
| Thermal Shock | MIL-STD-202G | -40℃(30min)←→100℃(30min) | 300 300 cycles | 22 | 0/22 |
| Temperature And Humidity Cyclic | JEITA ED-4701 200 203 | -10℃——+65℃, 0%-90%RH 24hrs./1cycle | 10 10 cycles | 22 | 0/22 |
| High Temperature Storage | JEITA ED-4701 200 201 | Ta=100℃ | 1000h | 22 | 0/22 |
| Low Temperature Storage | JEITA ED-4701 200 202 | Ta=-40℃ | 1000h | 22 | 0/22 |
| High Temperature High Humidity Storage | JEITA ED-4701 100 103 | Ta=60℃, RH=90% | 1000h | 22 | 0/22 |
| Life Test | JESD22-A108D | Ta=25℃ IF _R =15mA,IF _G =8mA,IF _B =5mA | 1000h | 22 | 0/22 |
| High Temperature Life Test | JESD22-A108D | Ta=85℃ IF _R =15mA,IF _G =8mA,IF _B =5mA | 1000h | 22 | 0/22 |
| Low Temperature Life Test | JESD22-A108D | Ta=-40℃ IF _R =15mA,IF _G =8mA,IF _B =5mA | 1000h | 22 | 0/22 |
| Resistance to Soldering Heat | GB/T 4937, II ,2.2&2.3 | Tsol*=260℃ 10sec. | 2 2 times | 22 | 0/22 |

Criteria For Judging Damage

| Test Items | Symbol | Test Conditions | Criteria For Judging Damage |
|------------------------------|----------------|----------------------------------|--|
| Forward Voltage | V _F | I _F = I _{FT} | Initial Data±10% |
| Reverse Current | I _R | V _R = 5V | I _R ≤10μA |
| Luminous Intensity | I _V | I _F = I _{FT} | Average I _V degradation≤30%; Single LED I _V degradation≤50% |
| Resistance to Soldering Heat | | | No dead light exists. |

* Note: T_{sol}-Temperature of tin liquid; I_{FT}: Typical current.

Outline Dimension

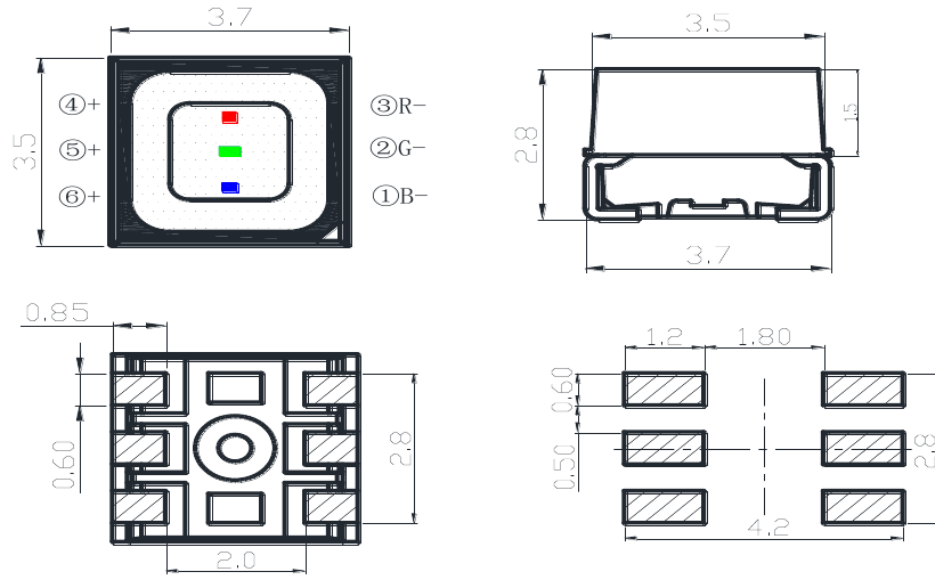

Recommended Soldering Pad

Note:

A : Nick Mark

All dimensions in mm.

Tolerances: X.X ±0.1 mm

X.XX ±0.05mm

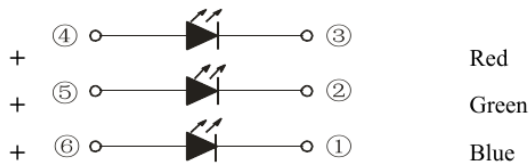

Polarity

Packaging (1)

◇ Carrier Tape

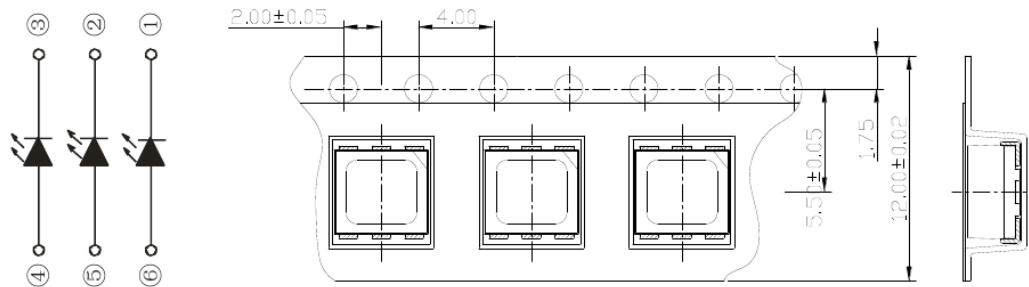

All dimensions in mm, tolerances unless mentioned is ± 0.1 mm.

◇ Details Of Carrier Tape

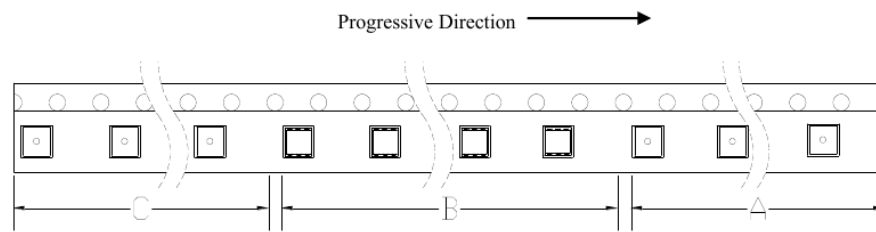

A: Leader, Empty, 500mm; B:3000 Lamps Loaded; C: Trailer, Empty, 100mm.

◇ Reel Dimension

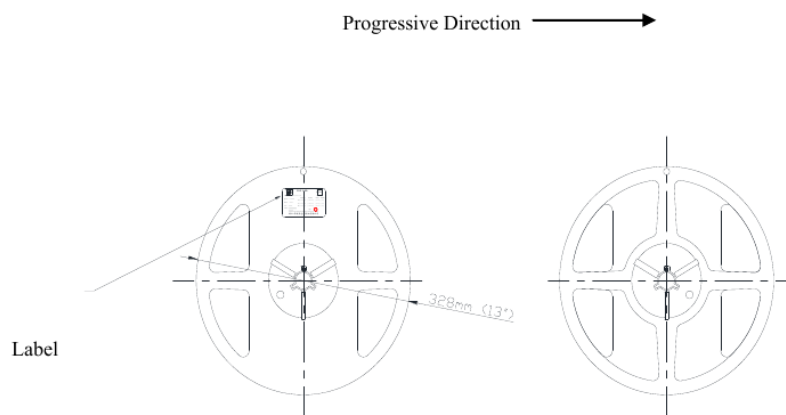

Packaging(2)



Moisture Proof and Anti-Electrostatic Foil Bag

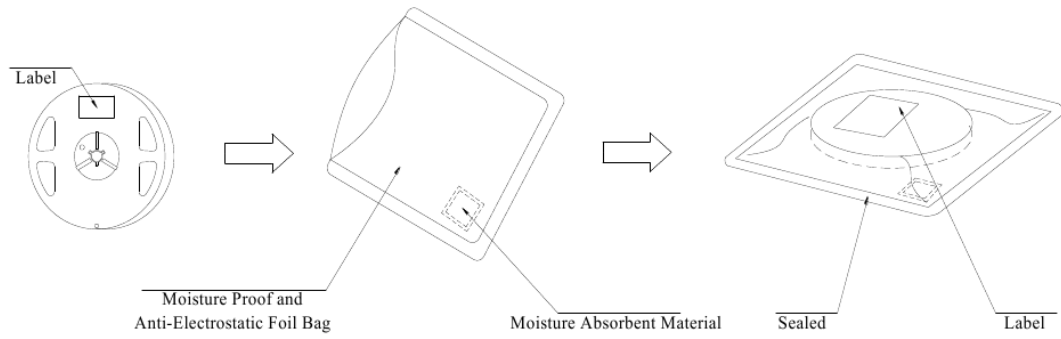

Cardboard Box

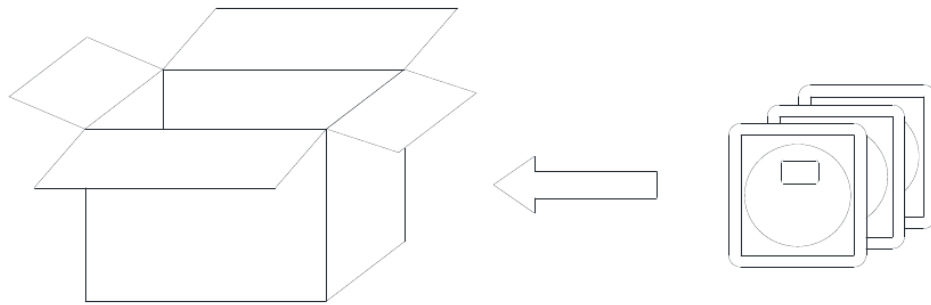

Guideline for Soldering (1)

1.

Hand Soldering

•

If manual soldering is used, the use of a soldering iron of less than 25W is recommended. The temperature of the iron must be kept below 315°C, with soldering time within 3 seconds and each electrode can be only soldered at one time.

•

The epoxy resin of the SMD LED should not contact the tip of the soldering iron.

•

No mechanical stress should be exerted on the resin portion by the tip of the soldering iron.

•

Handing of the SMD LED should be done when the temperature of environment is below 40°C, in case of LED failures caused by thermal-mechanical stress in condition of high temperature .

2.

Reflow Soldering: Use the conditions shown in the under Figure of Pb-Free Reflow Soldering.

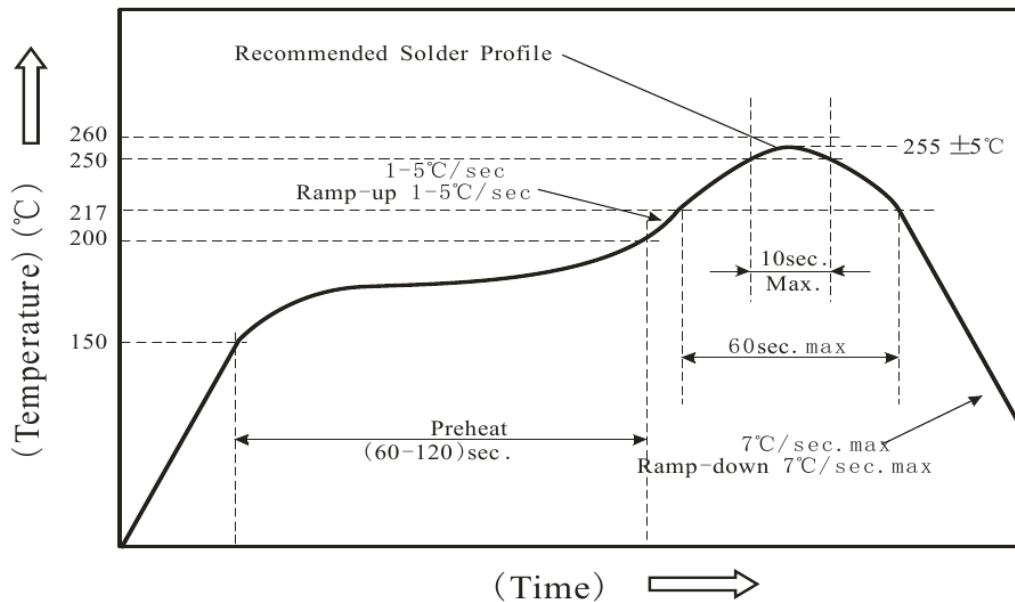

Guideline for Soldering (2)

- Reflow soldering should not be done more than one time.
- Stress on the LEDs should be avoided during heating in the reflow soldering process.
- After soldering, do not deal with the product before its temperature drop down to room temperature.

3.

Cleaning

-

It is recommended that alcohol (Anhydrous ethanol) be used as a solvent for cleaning after soldering. Cleaning is to go under 30°C for 3 minutes or 50°C for 30 seconds. When using other solvents, it should be confirmed beforehand whether the solvents will dissolve the package and the resin or not.

-

Ultrasonic cleaning is also an effective way for cleaning. The influence of Ultrasonic cleaning on LED depends on factors such as ultrasonic power. Generally, the ultrasonic power should not be higher than 300W, otherwise it will cause LED damage. Before cleaning, a pre-test should be done to confirm if any damage to LEDs will occur.

***Note:** This general guideline may not apply to all PCB designs and configurations of all soldering equipment. The technique in practice is influenced by many factors, it should be specialized base on the PCB designs and configurations of the soldering equipment.

Precautions (1)

1.

Storage

- Moisture proof, anti-electrostatic package and moisture absorbent material are used, to keep moisture to a minimum. Humidity indicator card inside to test if the products are moisted.
- Storage environment: Before opening the package, the product should be kept at 30°C or less and humidity less than 60% RH, When the storage time more than 2 months, need to be used to bake.
- Before using, please check whether there is any air leakage or not, If the bag has leaked air, Please bake the product with below condition.
- Before soldering ,the product must be stored under the condition of <30°C and <60%RH. Under these conditions the SMD LEDs must be used (subject to reflow oven) within 12 hours.
- Baking conditions: (70±5) °C × 24h.

2.

Static Electricity

- Static electricity or surge voltage damages the LEDs. Damaged LEDs will show some unusual characteristics such as the forward voltage becomes lower, or the LEDs can not be lighted up. In view of the above, we should

do some anti-static precautions when using the SMD LEDs.

Precautions (2)

- All devices, equipments and machineries must be properly grounded, at the same time we should take measures to prevent anti-static and voltage surge.
- It is also recommended that anti-electrostatic wrist bands, pads, uniforms, gloves or containers can be used when dealing with the LEDs.

3.

Design Consideration

- In designing a circuit, the current through each LED must not exceed the absolute maximum rating specified for each LED. In the meanwhile, resistors for protection should be applied, otherwise slight voltage shift will cause big current change which will probably lead to damage.
- It is recommended to use Circuit A which regulates the current flowing through each LED rather than Circuit B. When driving LEDs with a constant voltage in Circuit B, the current through the LEDs may vary due to the variation in Forward Voltage (V_F) of the LEDs. In the worst case, some LED may be subjected to stress in the excess of the Absolute Maximum Rating.

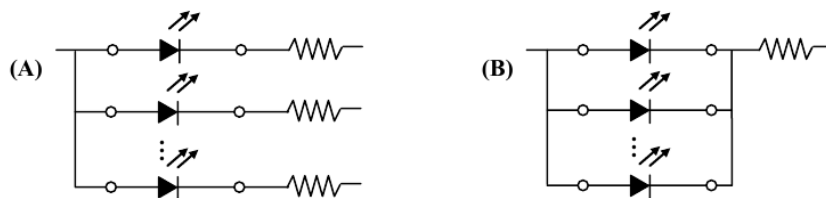

- Thermal Design is paramount importance because heat generation may result in the Characteristics decline,

Precautions (3)

such as brightness decrease, Color change and so on. Please consider the heat dissipation when making the system design.

4.

Reverse voltage protection

-

In general, the reverse current of LED is very small, which won't affect the normal use of components. But when it is often suffered the reverse voltage which exceeds the limit of the component then it will be damaged. Such as the reverse current increase rapidly. And it will cause the string light when the screen is black. So please pay attention to controlling the reverse voltage which less than 5 V is recommended.

5.

The safe temperature for LEDs working

-

The high temperature will make the LEDs' Luminous Intensity decreased radically, if LEDs are used in hot environment for a long time, they will be disabled easily. When LEDs are used in a high density array, we suggest that the LEDs' surface temperature should be lower than 55°C and the legs' temperature should be lower than 75°C.

6.

Others

-

When handling the product, touching the encapsulation with bare hands will not only contaminate its surface, but also have an effect on its optical characteristics. Excessive force to the encapsulation might result in catastrophic failure of the LEDs due to die breakage or wire deformation. For this reason, please do not put excessive stress on LEDs, especially when the LEDs are heated such as during Reflow Soldering.

Precautions (4)

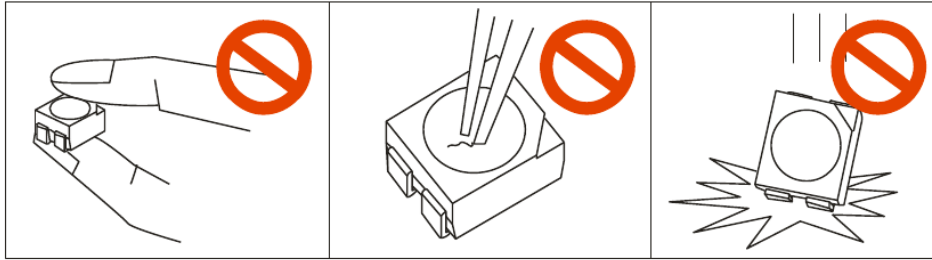

The epoxy resin of encapsulation is fragile, so please avoid scratch or friction over the epoxy resin surface.

While handling the product with tweezers, do not hold by the epoxy resin, be careful.