

Features

- Long operating life
- Low Power Consumption
- RoHS Compliant

Application

- PCB mounted infrared sensor.
- Infrared wireless data transmission r
- Optoelectronic switch
- Smoke detector



Part Number	Dice Material	Emitted Color	Lens Color
IE-2012IR-HB-C-08	GaAlAs	Infrared	Water Clear

Electro-Optical Characteristics(Ta=25°C)

Parameter	Symbol	Condition	Min	Typ	Max	Unit
Radiant Intensity	IE	IF=20mA	5.0	8.0	-	mW/sr
		IF=100mA Pulse Width≤100μs and Duty≤1%	-	60	-	
		IF=1A Pulse Width≤100μs and Duty≤1%	-	-	-	
Peak Wavelength	λP	IF=20mA	-	850	-	nm
Spectral Bandwidth	Δλ	IF=20mA	-	45	-	nm
Forward Voltage	VF	IF=20mA	-	1.45	1.65	V
		IF=100mA Pulse Width≤100μs and Duty≤1%	-	1.80	2.40	
		IF=100mA Pulse Width≤100μs and Duty≤1%	-	-	-	
Reverse Current	IR	VR=5V	-	-	10	μA
View Angle	2θ1/2	IF=20mA	-	120	-	deg

Absolute Maximum Ratings(Ta=25°C)

Parameter	Symbol	Max.	Unit
Peak Forward Current(1/10 Duty Cycle, 0.1ms Pulse Width)	IPF	100	mA
Forward Current	IF	65	mA
Reverse Voltage	VR	5	v
Operating Temperature Range	Topr	-40to+90	°C
Storage Temperature Range	Tstg	-40to+90	°C
Reflow Soldering	Tsld	260°C for 10secs	

Optical & Electrical Characteristics

Fig.1 Forward Current vs. Ambient Temperature

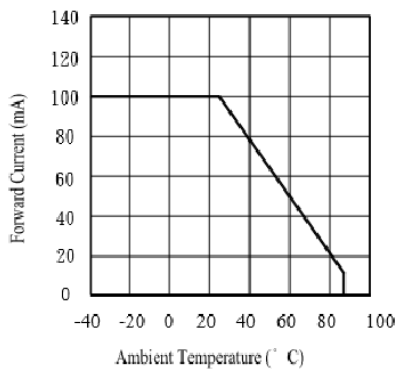

Fig.2 Spectral Distribution

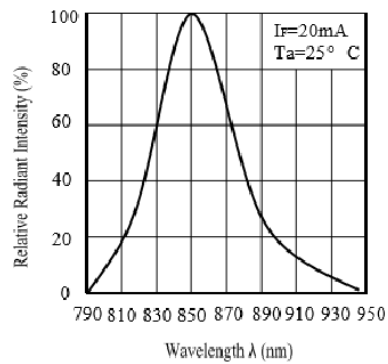

Fig.3 Peak Emission Wavelength vs. Ambient Temperature

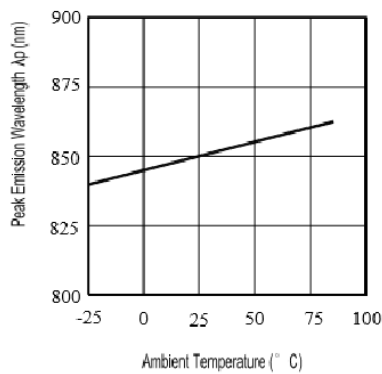

Fig.4 Forward Current vs. Forward Voltage

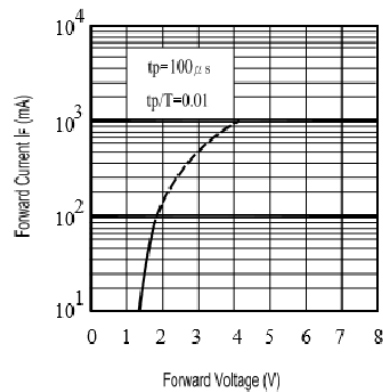

Fig.5 Relative Intensity vs.
Forward Current

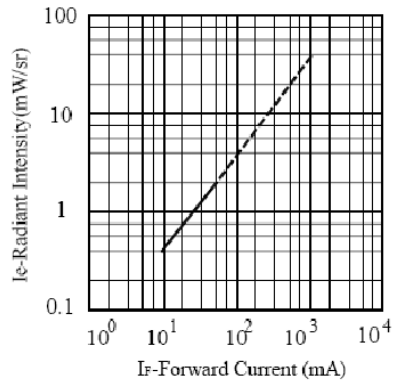

Fig.6 Relative Radiant Intensity vs.
Angular Displacement

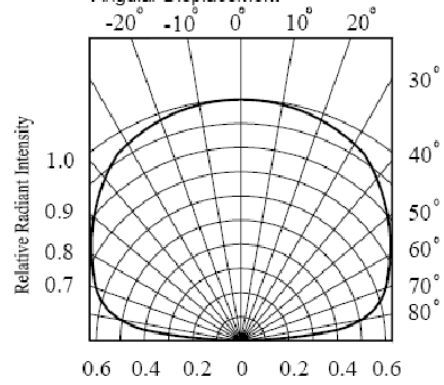

Fig.7 Relative Intensity vs.
Ambient Temperature($^\circ$ C)

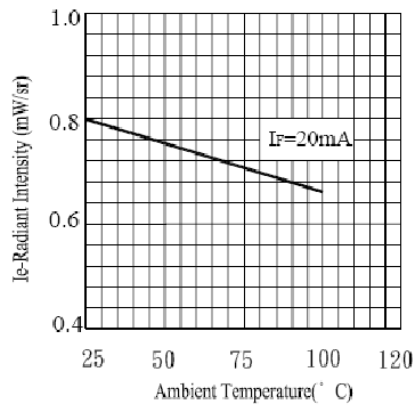
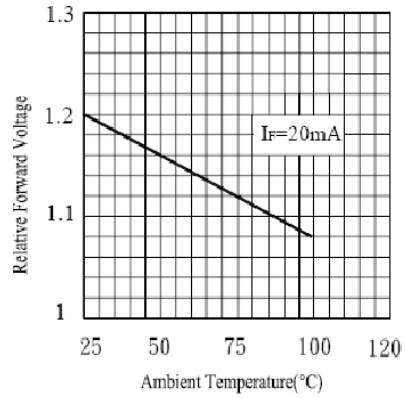

Fig.8 Forward Voltage vs.
Ambient Temperature($^\circ$ C)



Reliability Test Items And Conditions

Test Items	Reference	Test Conditions	Time	Quantity	Criterion
Thermal Shock	MIL-STD-202G	-40°C (30min) ~100°C (30min)	100 Cycles	22	0/22
Temperature And Humidity Cyclic	JEITA ED-4701 200 203	-10°C~65°C ; 0%~90%RH	10cycles	22	0/22
High Temperature Storage	JEITA ED -4071 200 201	Ta=100°C	1000H	22	0/22
Low Temperature Storage	JEITA ED -4071 200 202	Ta=-40°C	1000H	22	0/22
High Temperature High Humidity Storage	JEITA ED -4071 100 103	Ta=60°C ; RH=90%	1000H	22	0/22
High Temperature Life Test	JESD22-A108D	Ta=80°C	1000H	22	0/22
Life Test	JESD22-A108D	Ta=25°C IF=20mA	1000H	22	0/22
Resistance to Sodering Heat	GB/T 4937, II , 2.2&2.3	Tsol*=(240±5)°C 10secs	2 times	22	0/22

Criteria For Judging Damage

Test Items	Symbol	Test Conditions	Criteria For Judging Damage
Forward Voltage	V _F	I _F =I _{FT}	Initial Data±10%
Recerse Current	I _R	V _R =5V	I _R ≤10uA
Luminous Intensity	I _V	I _F =I _{FT}	Average I _V degradation≤30% ; Single LED I _V degradation≤50%
Resistance to Soldering Heat			Material without internal cracks,no material between stripped,no deaded light

product size

(Unit : mm)

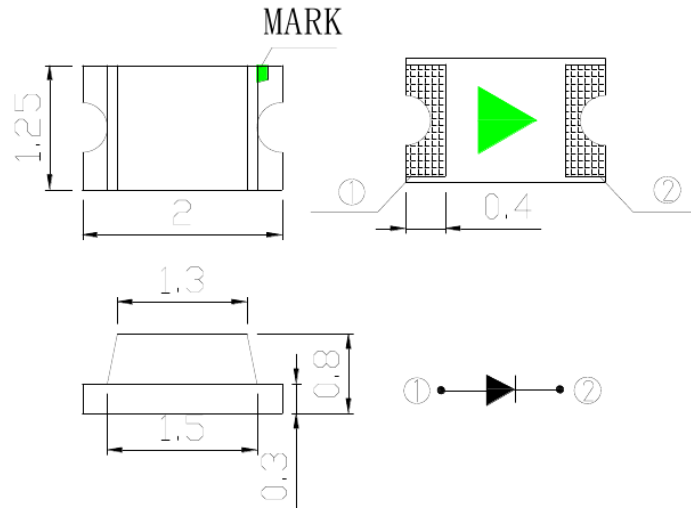

NOTES

1. All dimensions are in millimeters (inches)
2. Tolerances are $\pm 0.2\text{mm}$ (0.008inch) unless otherwise noted.

Recommended Soldering Pad Design

(Unit : mm)

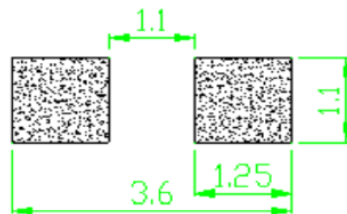

Taping and package Spec

- Tape Specification:3,000pcs Per Reel

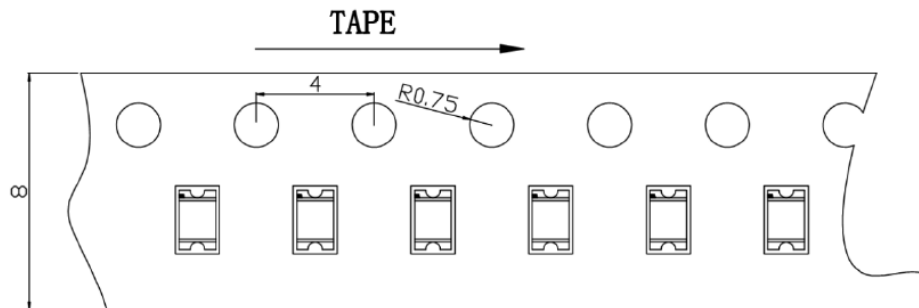

Packaging

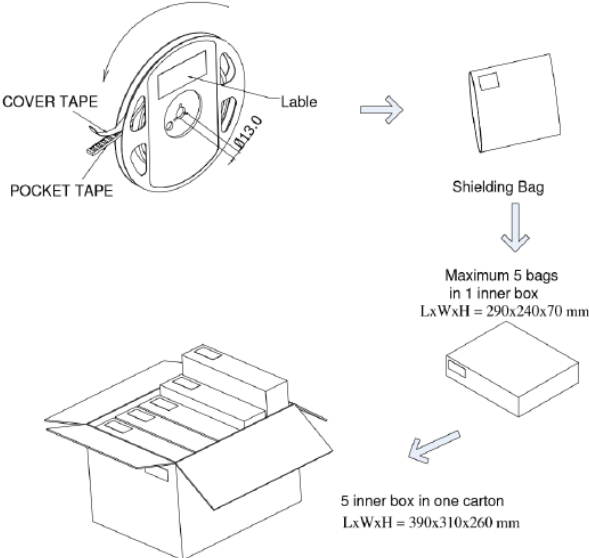

Useful hint

Reflow Soldering Instructions

Lead Solder

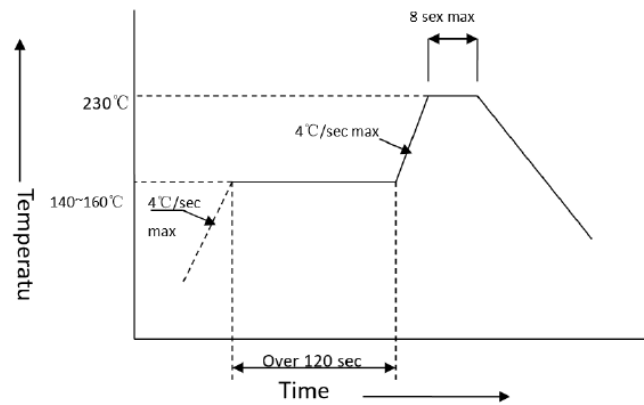

Lead-Free Solder

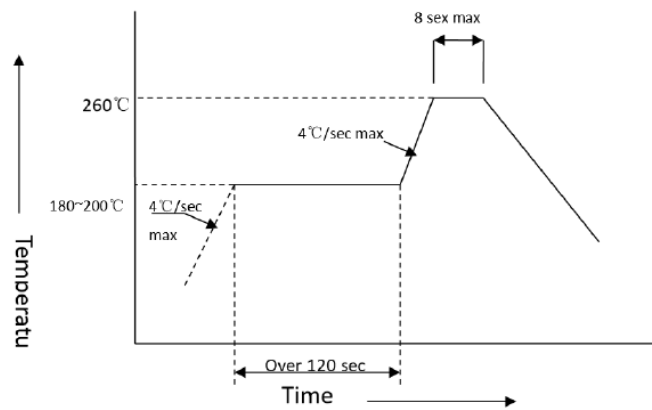

- Reflow soldering should not be done more than two times
- Stress on the LEDs should be avoided during heating in soldering process
- After soldering, do not deal with the product before its temperature drop down to room Temperature.

Precautions

1. Storage

-

Moisture proof and anti-electrostatic package with moisture absorbent material is used, to keep moisture to a minimum.

-

Before opening the package, the product should be kept at 30°C or less and humidity less than 60% RH, and be used within a year.

-

After opening the package, the product should be stored at 30°C or less and humidity less than 10%RH, and be soldered within 24 hours (1 day). It is recommended that the product be operated at the workshop condition of 30°C or less and humidity less than 60%RH.

-

If the moisture absorbent material has faded away or the LEDs have exceeded the storage time, baking treatment should be performed based on the following condition: (70±5)°C for 24 hours.

2. Static Electricity

Static electricity or surge voltage damages the LEDs. Damaged LEDs will show some unusual characteristics such as the forward voltage becoming lower, or the LEDs do not light at the low current, even not light.

All devices, equipment and machinery must be properly grounded. At the same time, it is recommended that wrist bands or anti-electrostatic gloves, anti-electrostatic containers be used when dealing with the LEDs.

3. Vulcanization

LED curing is due to sulfur being in brackets and the +1 price of silver in the chemical reaction generated Ag₂S in the process. It will lead to the capacity of reflecting of silver layer reducing, light color temperature drift and serious decline, seriously affecting the performance of the product. So we should take corresponding measures to avoid vulcanization, such as to avoid using sulphur volatile substances and keeping away from high sulphur content of the material.