SPECIFICATION FOR LCM MODULE

(Customer Name) :	
Customer P/N.) :	
(TCC P/N.) :	IE-E-078080128W7-1
(TCC C/N.) :	
(Version No.) :	01
Date) :	20210606

(Signature)	(Manager)	(Sales)	(Engineering)	(QA)

(Customer approval)	
----------------------------	--

- ※ We promise that our products conform to the sample furnished in quality,
- ※ In case of any special requirement on the quality, please feel free to contact our sales engineers.
- ※ Thanks for awarding this opportunity of sample approval, please return this form to us for filing after authentication.

PRODUCT CONTENTS

■ PHYSICAL DATA (物理参数)	5
■ ABSOLUTE MAXIMUM RATINGS (极限参数)	6
■ EXTERNAL DIMENSIONS (外形尺寸)	7
■ ELECTRICAL CHARACTERISTICS (电气特性)	8
◆ DC Characteristics (直流特性)	8
◆ AC Characteristics (交流特性)	9
■ TIMING OF POWER SUPPLY (电源时序)	14
■ ELECTRO-OPTICAL CHARACTERISTICS (光电参数)	15
■ INTERFACE PIN CONNECTIONS (引脚接口)	16
■ COMMAND TABLE (指令表)	17
■ INITIALIZATION CODE (初始化代码)	24
■ SCHEMATIC EXAMPLE (应用电路)	26
◆ 8080 Series Interface Application Circuit	26
◆ 6800 Series Interface Application Circuit	27
◆ SPI Series Interface Application Circuit	28
◆ I ² C Series Interface Application Circuit	29
■ RELIABILITY TESTS (可靠性测试)	30
■ OUTGOING QUALITY CONTROL SPECIFICATION (出厂质量控制规范)	31
◆ Standard (标准)	31
◆ Definition (定义)	31
◆ Inspection Methods (检查方法)	31
◆ Inspection Criteria (检查标准)	32
■ CAUTIONS IN USING OLED MODULE (OLED 模块使用注意事项)	34
◆ Precautions for Handling OLED Module (处理 OLED 模块的注意事项)	34
◆ Precautions for Storing OLED Module (OLED 模块存储注意事项)	37
◆ Using OLED Modules (OLED 模块使用注意事项)	38
◆ Precautions for Soldering OLED Module (OLED 模块焊接注意事项)	39
◆ Precautions for Operation (工作运行注意事项)	40
◆ Safety 安全	40
◆ Limited Warranty (有限质保)	41
◆ Return OLED Module under Warranty (OLED 模块返修质保)	41

■ PRIOR CONSULT MATTER (提前商议事项) 42

■ PHYSICAL DATA (物理参数)

NO.	Items	Specification:	Unit
1	Diagonal Size 尺寸	2.23	Inch
2	Resolution 分辨率	128 x 32	Dots
3	Active Area 有效显示区域	55.02(W) x 13.10(H)	mm ²
4	Outline Dimension 外围尺寸	62.00(W) x 24.00(H)	mm ²
5	Pixel Pitch 像素间距	0.43 (W) x 0.41 (H)	mm ²
6	Pixel Size 像素尺寸	0.41 (W) x 0.39 (H)	mm ²
7	Driver IC 驱动 IC	SSD1305Z	-
8	Display Color 显示色彩	White	-
9	Gray Scale 灰阶	1	Bit
10	Interface 接口	Parallel / SPI / IIC	-
11	IC Package Type IC 封装类型	COG	-
12	Module Connecting Type 模块连接方式	ZIF	-
13	Thickness 厚度	2.00 ±0.2	mm
14	Weight 重量	6.0 ± 10%	g
15	Duty 占空比	1/32	-

■ ABSOLUTE MAXIMUM RATINGS (极限参数)

Unless otherwise specified, VSS = 0V

(Ta=25 °C)

除另行规定外, VSS=0V

Items	Min.	Max.	Unit	Remark
Supply Voltage (VDD)	-0.3	+4.0	V	IC maximum rating
Supply Voltage(VCC)	0	+16.0	V	IC maximum rating
Operating Temperature(T _{OP})	-30	80	°C	-
Storage Temperature(T _{ST})	-40	85	°C	Note 2

NOTE:

1. Permanent device damage may occur if ABSOLUTE MAXIMUM RATINGS are exceeded. Functional operation should be restricted to the conditions as detailed in the operational sections of this data sheet. Exposure to absolute maximum rating conditions for extended periods may affect reliability.
如果超过极限参数可能会导致器件永久性损坏。实际工作条件应仅限于在本数据表格中详述的操作部分。在极限参数条件下长时间工作会影响其可靠性。
2. The defined temperature ranges do not include the polarizer. The maximum withstood temperature of the polarizer should be 80 °C.
定义的温度范围不包括偏光片。偏光片的最大值耐温应为 80°C。

EXTERNAL DIMENSIONS (外形尺寸)

Customer No. :

- ROHS COMPLIANT
- ROHS COMPLIANT AND HALOGEN-FREE
- RESTRICTED SUBSTANCE CONTROL STANDARD. (VERSION : _____)

PIN DESCRIPTION

1	NC (GND)
2	V _{SS}
3	V _{SS}
4	NC
5	V _{DD}
6	BS1
7	BS2
8	CS#
9	RES#
10	D/C#
11	R/W#
12	E/RD#
13	D0
14	D1
15	D2
16	D3
17	D4
18	D5
19	D6
20	D7
21	IREF
22	V _{COMH}
23	V _{CC}
24	NC (GND)

contact side

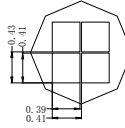
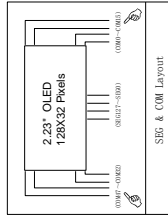
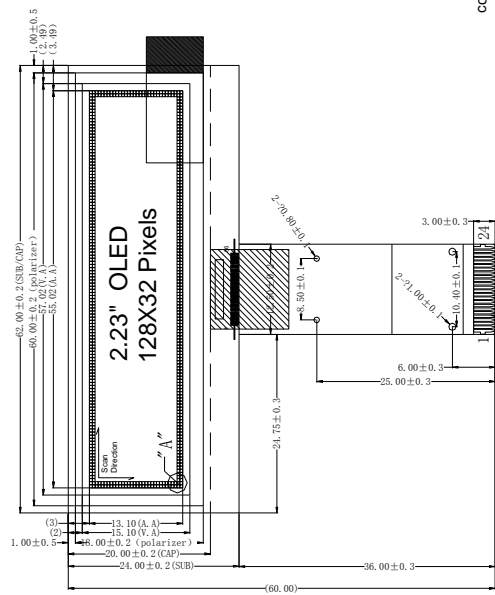
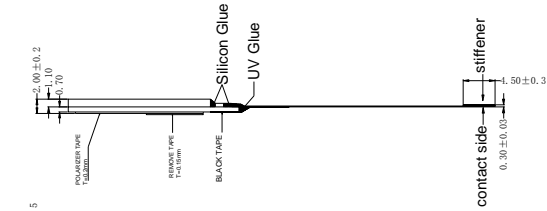
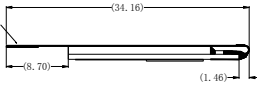

"A"--DOTS DETAIL /SCALE 10X

CUSTOMER APPROVE		有机发光二极管显示屏		IE-E-078080128W7-1	
Mechanical	Electrical	1/32	DUTY	PRODUCT NO.	REV
			BIAS		A
			Vop	DWN	DSN
			VDD	CHKD	APPD
			of CLOCK	NOT IN SCALE	UNIT mm
			NO.	DATE	SHEET: 1/1
			NEW		
			CONTENT		

- NOTES:
1. OPERATING TEMP: -30 °C TO 80 °C
 2. STORAGE TEMP: -40 °C TO 80 °C
 3. VIEWING DIRECTION: ALL
 4. OLED DRIVE IC: SSD1305Z
 5. DISPLAY COLOR: WHITE
 6. UNSPECIFIED TOLERANCES: ±0.3mm.
 7. () MEANS: DIMENSION FOR REFERENCE

■ ELECTRICAL CHARACTERISTICS (电气特性)

◆ DC Characteristics (直流特性)

Unless otherwise specified, Voltage referenced to VSS;

除另行规定外, 参考电平为 VSS;

VDD=3.0V, VCC = 12.5V, IREF = 10uA,

(Ta = 22 ± 3°C, 60 ± 10%RH)

Items		Symbol	Min.	Typ.	Max.	Unit
Supply Voltage	Logic Supply Voltage	V _{DD}	2.4	2.8	3.5	V
	Operating (for OLED panel)	V _{CC}	12.0	12.5	13.0	V
Input Voltage	High Voltage	V _{IH}	0.8xV _{DD}	-	-	V
	Low Voltage	V _{IL}	-	-	0.2xV _{DD}	V
Output Voltage	High Voltage	V _{OH}	0.9xV _{DD}	-	-	V
	Low Voltage	V _{OL}	-	-	0.1xV _{DD}	V

◆ AC Characteristics (交流特性)

Conditions:

Voltage referenced to V_{SS}

$V_{DD}=2.4$ to $3.5V$

$T_A = 25^{\circ}C$

Table 13-1 : AC Characteristics

Symbol	Parameter	Test Condition	Min	Typ	Max	Unit
FOSC ⁽¹⁾	Oscillation Frequency of Display Timing Generator	$V_{DD} = 2.8V$	324	360	396	kHz
FFRM	Frame Frequency for 64 MUX Mode	132x64 Graphic Display Mode, Display ON, Internal Oscillator Enabled	-	$F_{OSC} \times 1/(D \times K \times 64)$ ⁽²⁾	-	Hz
RES#	Reset low pulse width		3	-	-	us

Note

⁽¹⁾ Fosc stands for the frequency value of the internal oscillator and the value is measured when command D5h A[7:4] is in default value.

⁽²⁾ D: divide ratio (default value = 1)

K: number of display clocks (default value = 54)

Please refer to Table 9-1 (Set Display Clock Divide Ratio/Oscillator Frequency, D5h) for detailed description

1. 6800-Series MCU Parallel Interface Timing Characteristics

6800-Series MCU Parallel Interface Timing Characteristics

($V_{DD} - V_{SS} = 2.4V$ to $3.5V$, $V_{DDIO} = V_{DD}$, $T_A = 25^\circ C$)

Symbol	Parameter	Min	Typ	Max	Unit
t_{cycle}	Clock Cycle Time	300	-	-	ns
t_{AS}	Address Setup Time	0	-	-	ns
t_{AH}	Address Hold Time	0	-	-	ns
t_{DSW}	Write Data Setup Time	40	-	-	ns
t_{DHW}	Write Data Hold Time	7	-	-	ns
t_{DHR}	Read Data Hold Time	20	-	-	ns
t_{OH}	Output Disable Time	-	-	70	ns
t_{ACC}	Access Time	-	-	140	ns
PW_{CSL}	Chip Select Low Pulse Width (read) Chip Select Low Pulse Width (write)	120 60	-	-	ns
PW_{CSH}	Chip Select High Pulse Width (read) Chip Select High Pulse Width (write)	60 60	-	-	ns
t_R	Rise Time	-	-	40	ns
t_F	Fall Time	-	-	40	ns

6800-series MCU parallel interface characteristics

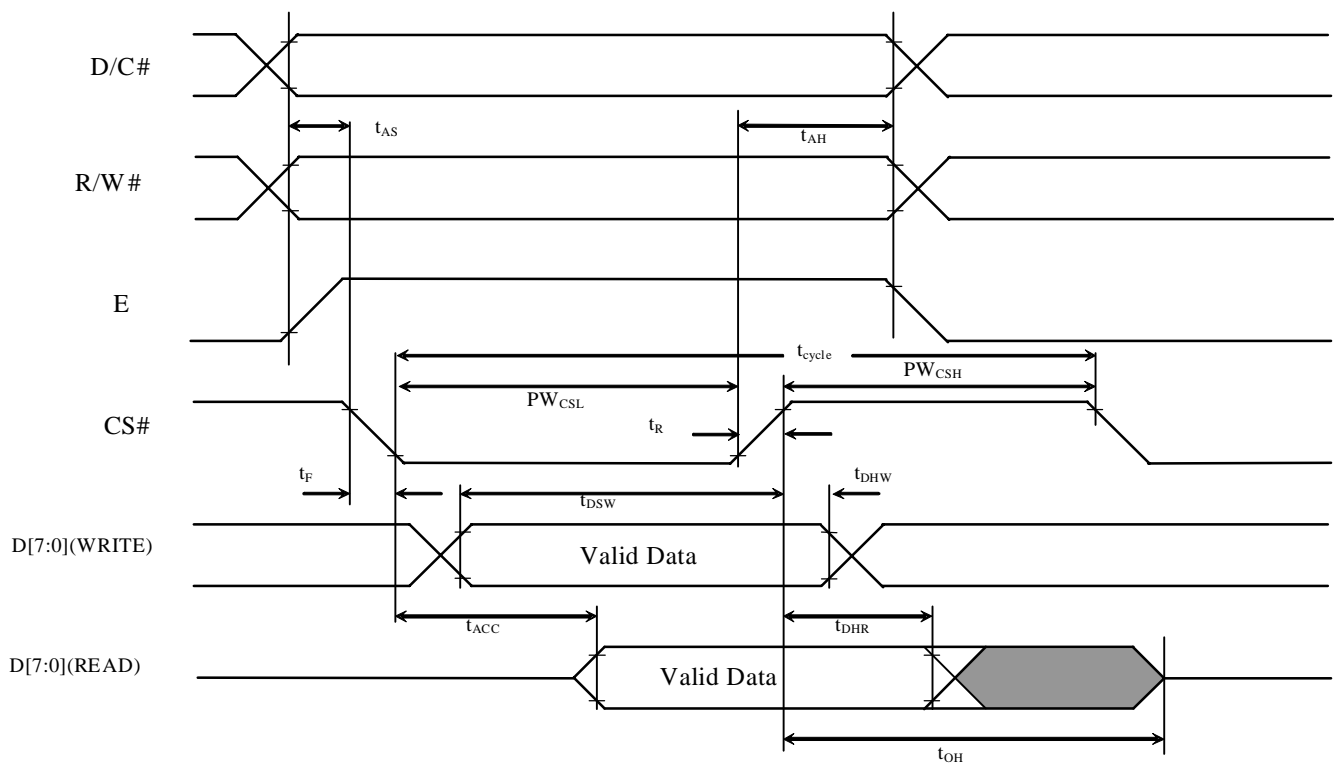

2. 8080-Series MCU Parallel Interface Timing Characteristics

8080-Series MCU Parallel Interface Timing Characteristics

($V_{DD} - V_{SS} = 2.4V$ to $3.5V$, $V_{DDIO} = V_{DD}$, $T_A = 25^\circ C$)

Symbol	Parameter	Min	Typ	Max	Unit
t_{cyc}	Clock Cycle Time	300	-	-	ns
t_{AS}	Address Setup Time	10	-	-	ns
t_{AH}	Address Hold Time	0	-	-	ns
t_{DSW}	Write Data Setup Time	40	-	-	ns
t_{DHW}	Write Data Hold Time	7	-	-	ns
t_{DHR}	Read Data Hold Time	20	-	-	ns
t_{OH}	Output Disable Time	-	-	70	ns
t_{ACC}	Access Time	-	-	140	ns
t_{PWLR}	Read Low Time	120	-	-	ns
t_{PWLW}	Write Low Time	60	-	-	ns
t_{PWHR}	Read High Time	60	-	-	ns
t_{PWHW}	Write High Time	60	-	-	ns
t_R	Rise Time	-	-	40	ns
t_F	Fall Time	-	-	40	ns
t_{CS}	Chip select setup time	0	-	-	ns
t_{CSH}	Chip select hold time to read signal	0	-	-	ns
t_{CSF}	Chip select hold time	20	-	-	ns

8080-series parallel interface characteristics (Form 1)

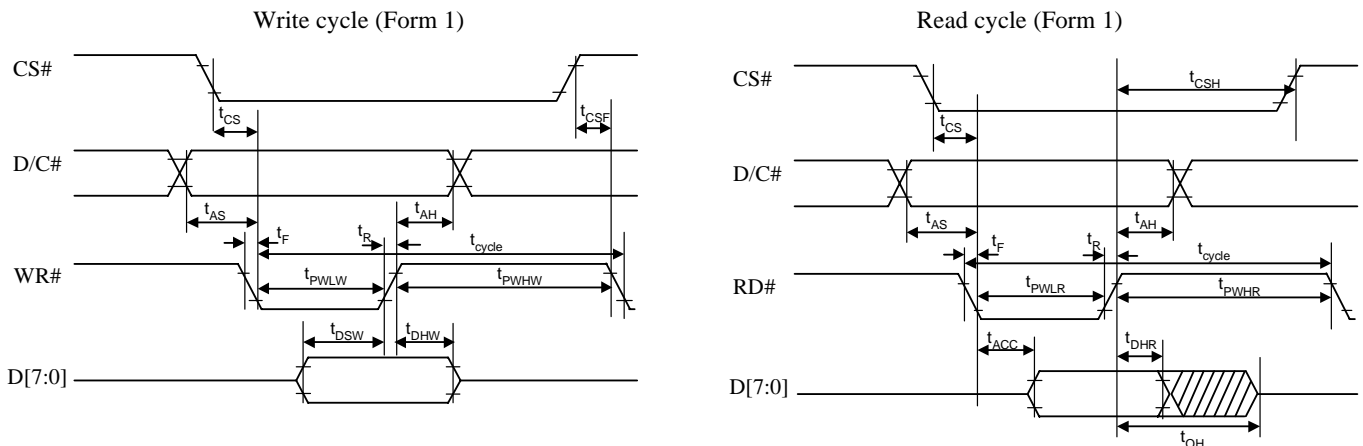

8080-series parallel in terface characteristics (Form 2)

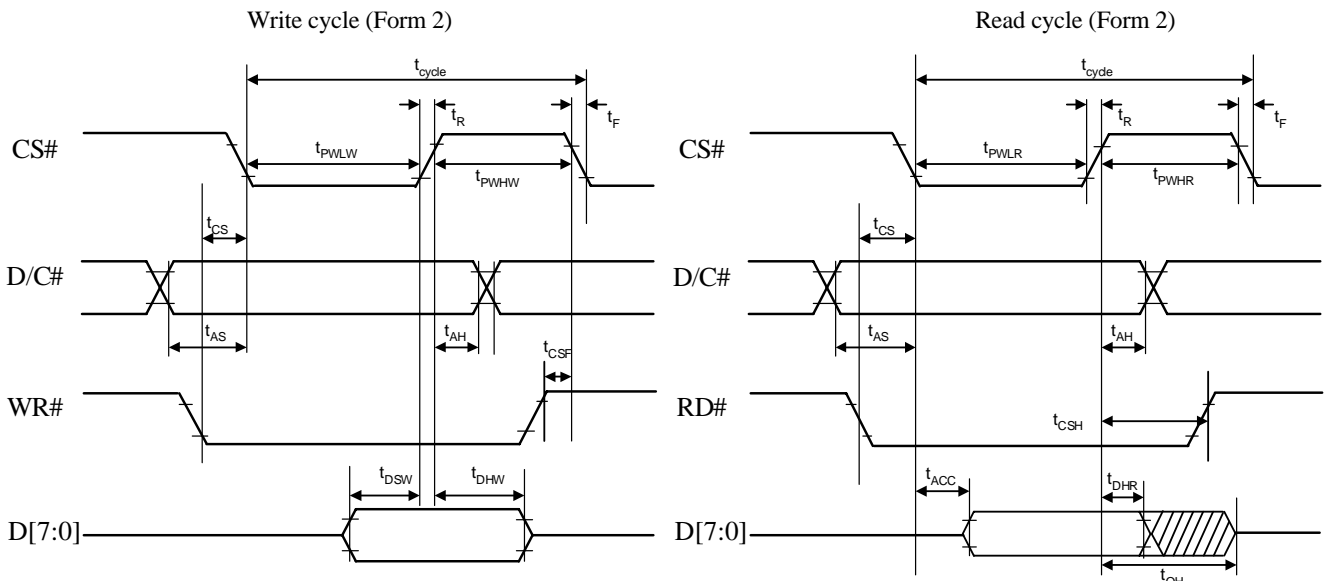

3. Serial Interface Timing Characteristics

Serial Interface Timing Characteristics

($V_{DD} - V_{SS} = 2.4V$ to $3.5V$, $V_{DDIO} = V_{DD}$, $T_A = 25^\circ C$)

Symbol	Parameter	Min	Typ	Max	Unit
t_{cycle}	Clock Cycle Time	250	-	-	ns
t_{AS}	Address Setup Time	150	-	-	ns
t_{AH}	Address Hold Time	150	-	-	ns
t_{CSS}	Chip Select Setup Time	120	-	-	ns
t_{CSH}	Chip Select Hold Time	60	-	-	ns
t_{DSW}	Write Data Setup Time	50	-	-	ns
t_{DHW}	Write Data Hold Time	15	-	-	ns
t_{CLKL}	Clock Low Time	100	-	-	ns
t_{CLKH}	Clock High Time	100	-	-	ns
t_R	Rise Time	-	-	40	ns
t_F	Fall Time	-	-	40	ns

Serial interface characteristics

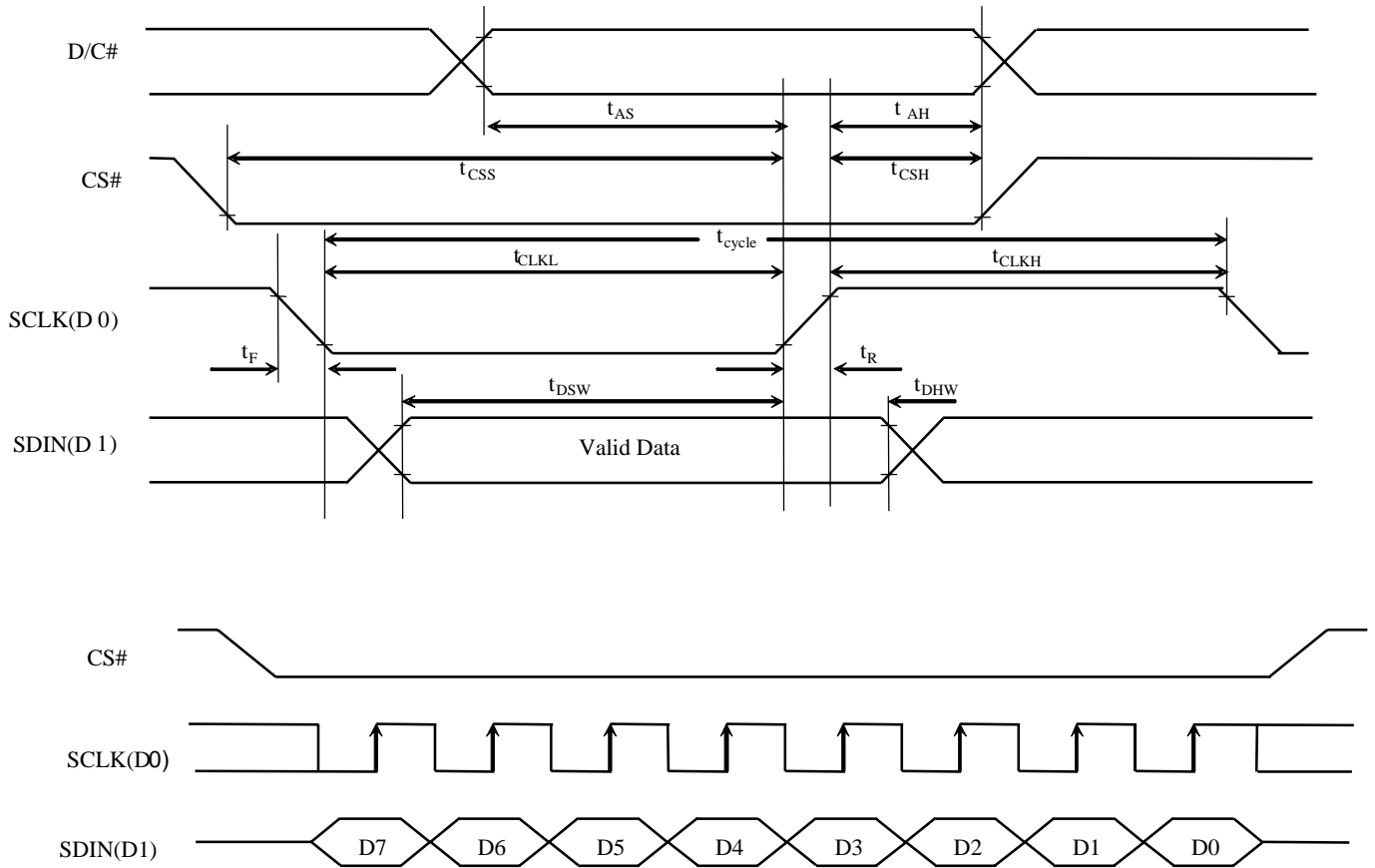

4. I²C Interface Timing Characteristics

Conditions:

$$V_{DD} - V_{SS} = 2.4 \text{ to } 3.5\text{V}$$

$$V_{DDIO} = V_{DD}$$

$$T_A = 25^\circ\text{C}$$

I²C Interface Timing Characteristics

Symbol	Parameter	Min	Typ	Max	Unit
t_{cycle}	Clock Cycle Time	2.5	-	-	us
t_{HSTART}	Start condition Hold Time	0.6	-	-	us
t_{HD}	Data Hold Time (for "SDA _{OUT} " pin)	0	-	-	ns
	Data Hold Time (for "SDA _{IN} " pin)	300	-	-	ns
t_{SD}	Data Setup Time	100	-	-	ns
t_{SSTART}	Start condition Setup Time (Only relevant for a repeated Start condition)	0.6	-	-	us
t_{SSTOP}	Stop condition Setup Time	0.6	-	-	us
t_{R}	Rise Time for data and clock pin	-	-	300	ns
t_{F}	Fall Time for data and clock pin	-	-	300	ns
t_{IDLE}	Idle Time before a new transmission can start	1.3	-	-	us

I²C interface Timing characteristics

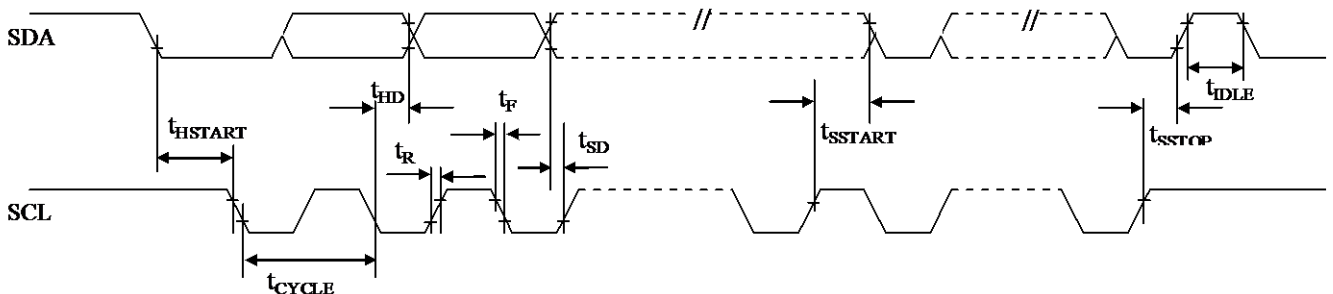

■ TIMING OF POWER SUPPLY (电源时序)

The following figures illustrate the recommended power ON and power OFF sequence of SSD1305 (assume V_{DD} and V_{DDIO} are at the same voltage level).

Power ON sequence:

1. Power ON V_{DD} , V_{DDIO} .
2. After V_{DD} , V_{DDIO} become stable, set RES# pin LOW (logic low) for at least 3 μ s (t_1)⁽⁴⁾ and then HIGH (logic high).
3. After set RES# pin LOW (logic low), wait for at least 3 μ s (t_2). Then Power ON V_{CC} .⁽¹⁾
4. After V_{CC} become stable, send command AFh for display ON. SEG/COM will be ON after 100ms (t_{AF}).

The Power ON sequence

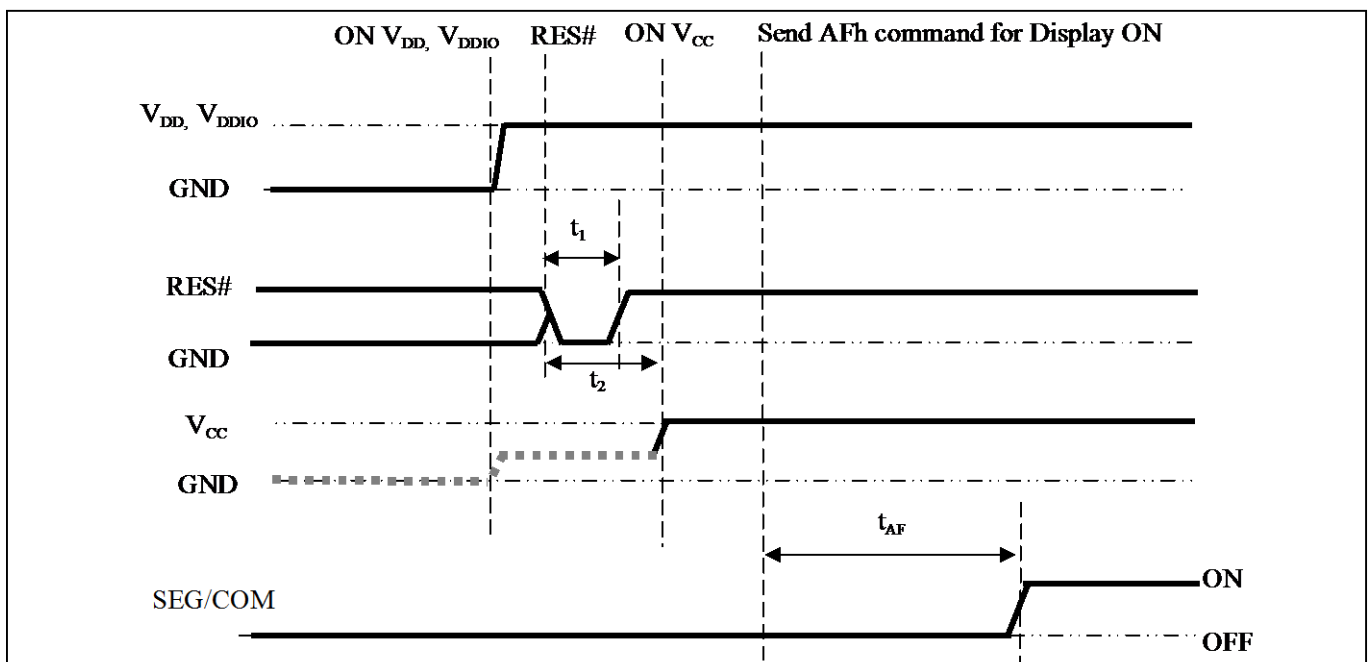

Power OFF sequence:

1. Send command AEh for display OFF.
2. Power OFF V_{CC} .^{(1), (2), (3)}
3. Wait for t_{OFF} . Power OFF V_{DD} , V_{DDIO} . (where Minimum $t_{OFF}=0\text{ms}$ ⁽⁵⁾, Typical $t_{OFF}=100\text{ms}$)

The Power OFF sequence

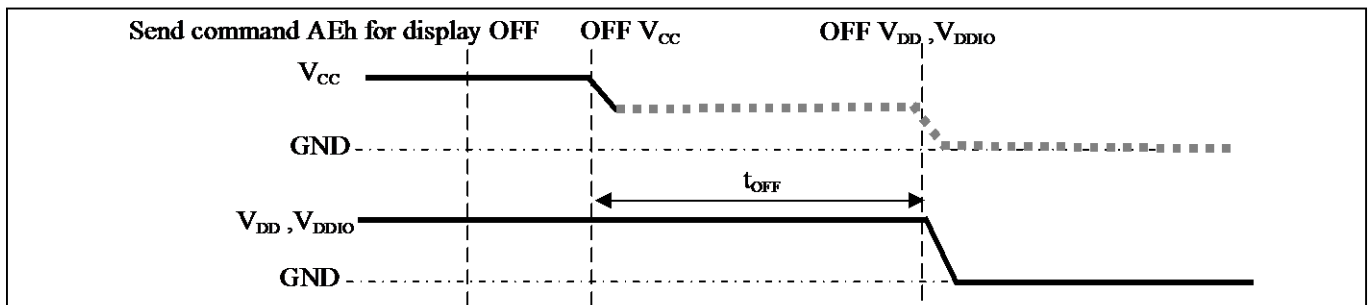

Note:

⁽¹⁾ Since an ESD protection circuit is connected between V_{DD} , V_{DDIO} and V_{CC} , V_{CC} becomes lower than V_{DD} whenever V_{DD} , V_{DDIO} is ON and V_{CC} is OFF as shown in the dotted line of V_{CC} .

⁽²⁾ V_{CC} should be kept float (disable) when it is OFF.

⁽³⁾ Power Pins (V_{DD} , V_{CC}) can never be pulled to ground under any circumstance.

⁽⁴⁾ The register values are reset after t_1 .

⁽⁵⁾ V_{DD} should not be Power OFF before V_{CC} Power OFF.

■ ELECTRO-OPTICAL CHARACTERISTICS (光电参数)

All data in below based the condition ($T_a = 22 \pm 3^\circ\text{C}$, $60 \pm 10\% \text{RH}$).

以下参数均基于 $T_a = 22 \pm 3^\circ\text{C}$, $60 \pm 10\% \text{RH}$ 的条件。

Items	Symbol	Min.	Typ.	Max.	Unit	Remark	
Operating Luminance 工作亮度	L	80	100	-	cd /m ²	All pixels ON With Polarizer	
Power Consumption 功耗	P	-	125	155	mW	30% pixels ON	
Frame Frequency 帧频	Fr	-	220	-	Hz	-	
Color Coordinate 色坐标	White	CIE x	0.25	0.29	0.33	CIE1931	Darkroom
		CIE y	0.27	0.31	0.35		
Response Time 响应时间	Rise	Tr	-	10	-	us	-
	Decay	Td	-	10	-	us	-
Contrast Ratio* 对比度	Cr	10000:1	-	-	-	Darkroom	
Viewing Angle 可视角	$\Delta\theta$	160	-	-	Degree	-	
Operating Life Time* 工作寿命	Top	20,000	-	-	Hours	$L = 100 \text{ cd/m}^2$	

Note(注意事项) :

1. 100 cd/m^2 is based on $V_{DD}=2.8\text{V}$, $V_{CC}=12.5\text{V}$, Contrast command setting $0x6F$;

100 cd/m^2 基于 $V_{DD}=2.8\text{V}$, $V_{CC}=12.5\text{V}$, 对比度设置为 $0x6F$;

2. **Contrast ratio** is defined as follows(对比度的定义如下):

$$\text{Contrast ratio} = \frac{\text{Photo - detector output with OLED being "white"}}{\text{Photo - detector output with OLED being "black"}}$$

对比度 = $\frac{\text{OLED 显示全屏亮时的亮度}}{\text{OLED 显示全屏黑时的亮度}}$

3. **Life Time** is defined when the Luminance has decayed to less than 50% of the initial Luminance specification. (Odd and even chess board alternately displayed).(The initial value should be closed to the typical value after adjusting.)

寿命的定义为当亮度衰减到初始亮度 50%时所消耗的时间。(奇数和偶数棋盘交替显示)。(初始亮度值应调试到接近典型值的大小)。

■ INTERFACE PIN CONNECTIONS (引脚接口)

No.	Symbol	Description															
1	NC(GND)	No connection.															
2	VLSS	Analog ground pin. It should be connected to VSS externally.															
3	VSS	This is a ground pin.															
4	NC	No connection.															
5	VDD	Power supply pin for core logic operation.															
6~7	BS1~BS2	<p>MCU bus interface selection pin. When it is pulled HIGH, the interface is set as IIC; the interface will be 4-wire SPI while this pin is pulled LOW.</p> <table border="1"> <thead> <tr> <th>Pin name</th> <th>I2C Interface</th> <th>6800-parallel</th> <th>8080-parallel</th> <th>Serial interface</th> </tr> </thead> <tbody> <tr> <td>BS1</td> <td>1</td> <td>0</td> <td>1</td> <td>0</td> </tr> <tr> <td>BS2</td> <td>0</td> <td>1</td> <td>1</td> <td>0</td> </tr> </tbody> </table> <p>Note: 0 is connected to Vss 1 is connected to VDD</p>	Pin name	I2C Interface	6800-parallel	8080-parallel	Serial interface	BS1	1	0	1	0	BS2	0	1	1	0
Pin name	I2C Interface	6800-parallel	8080-parallel	Serial interface													
BS1	1	0	1	0													
BS2	0	1	1	0													
8	CS#	Chip select pin. (Active LOW).															
9	RES#	Reset pin input, when the pin is pulled low, initialization of the chip is executed .Keep this pin HIGH (i.e. connected to VDD) during normal operation.															
10	D/C#	<p>This is Data/Command control pin.</p> <p>When it is pulled HIGH (i.e. connect to VDD), the data at D[7:0] is treated as data. When it is pulled LOW, the data at D[7:0] will be transferred to the command register.</p> <p>In I2C mode, this pin acts as SA0 for slave address selection.</p>															
11	R/W#	<p>This is read / write control input pin connecting to the MCU interface.</p> <p>When interfacing to a 6800-series microprocessor, this pin will be used as Read/Write (R/W#) selection input. Read mode will be carried out when this pin is pulled HIGH (i.e. connect to VDDIO) and write mode when LOW.</p> <p>When 8080 interface mode is selected, this pin will be the Write (WR#) input. Data write operation is initiated when this pin is pulled LOW and the chip is selected.</p> <p>When serial interface is selected, this pin must be connected to VSS.</p>															
12	E/RD#	<p>When interfacing to a 6800-series microprocessor, this pin will be used as the Enable (E) signal. Read/write operation is initiated when this pin is pulled HIGH (i.e. connect to VDDIO) and the chip is selected.</p> <p>When connecting to an 8080-microprocessor, this pin receives the Read (RD#) signal. Read operation is initiated when this pin is pulled LOW and the chip is selected.</p> <p>When serial interface is selected, this pin must be connected to VSS.</p>															
13~20	D0~D7	<p>These are 8-bit bi-directional data bus to be connected to the microprocessor's data bus.</p> <p>When serial interface mode is selected, D0 will be the serial clock input: SCLK; D1 will be the serial data input: SDIN and D2 should be left opened.</p> <p>When I2C mode is selected, D2, D1 should be tied together and serve as SDAout, SDAin in application and D0 is the serial clock input, SCL.</p>															
21	IREF	This is segment output current reference pin. A resistor should be connected between this pin and VSS to maintain the IREF current at 10uA.															
22	VCOMH	The pin is for COM signal deselected voltage level. A capacitor should be connected between this pin and VSS.															
23	VCC	Power supply for panel driving voltage. This is also the most positive power voltage.															
24	NC	No connection.															

■ COMMAND TABLE (指令表)

(D/C#=0, R/W#(WR#) = 0, E(RD#=1) unless specific setting is stated)

Fundamental Command Table											
D/C#	Hex	D7	D6	D5	D4	D3	D2	D1	D0	Command	Description
0	00~0F	0	0	0	0	X ₃	X ₂	X ₁	X ₀	Set Lower Column Start Address for Page Addressing Mode	Set the lower nibble of the column start address register for Page Addressing Mode using X[3:0] as data bits. The initial display line register is reset to 0000b after RESET.
0	10~1F	0	0	0	1	X ₃	X ₂	X ₁	X ₀	Set Higher Column Start Address for Page Addressing Mode	Set the higher nibble of the column start address register for Page Addressing Mode using X[3:0] as data bits. The initial display line register is reset to 0000b after RESET.
0 0	20 A[1:0]	0 *	0 *	1 *	0 *	0 *	0 *	0 A ₁	0 A ₀	Set Memory Addressing Mode	A[1:0] = 00b, Horizontal Addressing Mode A[1:0] = 01b, Vertical Addressing Mode A[1:0] = 10b, Page Addressing Mode (RESET) A[1:0] = 11b, Invalid
0 0 0	21 A[7:0] B[7:0]	0 A ₇ B ₇	0 A ₆ B ₆	1 A ₅ B ₅	0 A ₄ B ₄	0 A ₃ B ₃	0 A ₂ B ₂	0 A ₁ B ₁	1 A ₀ B ₀	Set Column Address	Setup column start and end address A[7:0] : Column start address, range : 0-131d, (RESET=0d) B[7:0]: Column end address, range : 0-131d, (RESET =131d)
0 0 0	22 A[2:0] B[2:0]	0 * *	0 * *	1 * *	0 * *	0 * *	0 A ₂ B ₂	1 A ₁ B ₁	0 A ₀ B ₀	Set Page Address	Setup page start and end address A[2:0] : Page start Address, range : 0-7d, (RESET = 0d) B[2:0] : Page end Address, range : 0-7d, (RESET = 7d)
0	40~7F	0	1	X ₅	X ₄	X ₃	X ₂	X ₁	X ₀	Set Display Start Line	Set display RAM display start line register from 0-63 using X ₅ X ₃ X ₂ X ₁ X ₀ . Display start line register is reset to 000000b during RESET.
0 0	81 A[7:0]	1 A ₇	0 A ₆	0 A ₅	0 A ₄	0 A ₃	0 A ₂	0 A ₁	1 A ₀	Set Contrast Control For BANK0	Double byte command to select 1 out of 256 contrast steps. Contrast increases as the value increases. (RESET = 80h)
0 0	82 A[7:0]	1 A ₇	0 A ₆	0 A ₅	0 A ₄	0 A ₃	0 A ₂	1 A ₁	0 A ₀	Set Brightness For Area Color Banks	Double byte command to select 1 out of 256 brightness steps. Brightness increases as the value increases. (RESET = 80h)
0 0 0 0 0	91 X[5:0] A[5:0] B[5:0] C[5:0]	1 * * * *	0 * * * *	0 X ₅ A ₅ B ₅ C ₅	1 X ₄ A ₄ B ₄ C ₄	0 X ₃ A ₃ B ₃ C ₃	0 X ₂ A ₂ B ₂ C ₂	0 X ₁ A ₁ B ₁ C ₁	1 X ₀ A ₀ B ₀ C ₀	Set Look Up Table (LUT)	Set current drive pulse width of BANK0, Color A, B and C. BANK0: X[5:0] = 31... 63; for pulse width set to 32 ~ 64 clocks (RESET = 110001b) Color A: A[5:0] same as above (RESET = 111111b) Color B: B[5:0] same as above (RESET = 111111b) Color C: C[5:0] same as above (RESET = 111111b) Note ⁽¹⁾ Color D pulse width is fixed at 64 clocks pulse.

Fundamental Command Table											
D/C#	Hex	D7	D6	D5	D4	D3	D2	D1	D0	Command	Description
0000	92	1	0	0	1	0	0	1	0	Set Bank Color of BANK1 to BANK16 (PAGE0)	Set the bank color of BANK1~BANK16 to any one of the 4 colors : A, B, C and D . A[1:0] : 00b, 01b, 10b, or 11b for Color = A, B, C or D of BANK1 A[3:2] : 00b, 01b, 10b, or 11b for Color = A, B, C or D of BANK2 : : D[5:4] : 00b, 01b, 10b, or 11b for Color = A, B, C or D of BANK15 D[7:6] : 00b, 01b, 10b, or 11b for Color = A, B, C or D of BANK16
0000	93	1	0	0	1	0	0	1	1	Set Bank Color of BANK17~BANK32 (PAGE1)	Set the bank color of BANK17~BANK32 to any one of the 4 colors: A, B, C and D. A[1:0] : 00b, 01b, 10b, or 11b for Color = A, B, C or D of BANK17 A[3:2] : 00b, 01b, 10b, or 11b for Color = A, B, C or D of BANK18 : : D[5:4] : 00b, 01b, 10b, or 11b for Color = A, B, C or D of BANK31 D[7:6] : 00b, 01b, 10b, or 11b for Color = A, B, C or D of BANK32
0	A0/A1	1	0	1	0	0	0	0	X ₀	Set Segment Re-map	X[0]=0b: column address 0 is mapped to SEG0 (RESET) X[0]=1b: column address 131 is mapped to SEG0
0	A4/A5	1	0	1	0	0	1	0	X ₀	Entire Display ON	X ₀ =0b: Resume to RAM content display (RESET) Output follows RAM content X ₀ =1b: Entire display ON Output ignores RAM content
0	A6/A7	1	0	1	0	0	1	1	X ₀	Set Normal/Inverse Display	X[0]=0b: Normal display (RESET) 0 in RAM: OFF in display panel 1 in RAM: ON in display panel X[0]=1b: inverse display 0 in RAM: ON in display panel 1 in RAM: OFF in display panel
00	A8 A[5:0]	1 *	0 *	1 A ₅	0 A ₄	1 A ₃	0 A ₂	0 A ₁	0 A ₀	Set Multiplex Ratio	Set MUX ratio to N+1 MUX N=A[5:0] : from 16MUX to 64MUX, RESET=11111b (i.e. 64MUX) A[5:0] from 0 to 14 are invalid entry.
0	AA	1	0	1	0	1	0	1	0	Reserved	Reserved
0000	AB A[3:0] B[7:0] C[7:0]	1 * B ₇ C ₇	0 * B ₆ C ₆	1 * B ₅ C ₅	0 * B ₄ C ₄	1 A ₃ B ₃ C ₃	0 A ₂ B ₂ C ₂	1 A ₁ B ₁ C ₁	1 A ₀ B ₀ C ₀	Dim mode setting	A[3:0] : Reserved (set as 0000b) B [7:0] : Set contrast for BANK0, valid range 0-255d, please refer to command 81h C [7:0] : Set brightness for color bank, valid range 0-255d, please refer to command 82h

Fundamental Command Table											
D/C#	Hex	D7	D6	D5	D4	D3	D2	D1	D0	Command	Description
0 0	AD A[7:0]	1 1	0 0	1 0	0 0	1 1	1 1	0 1	1 A ₀	Master Configuration	A[0]=0b, Select external V _{CC} supply (RESET) A[0]=1b, Reserved
0	AC AE AF	1	0	1	0	1	1	A ₁	A ₀	Set Display ON/OFF	ACh = Display ON in dim mode AEh = Display OFF (sleep mode) (RESET) AFh = Display ON in normal mode
0	B0~B7	1	0	1	1	0	X ₂	X ₁	X ₀	Set Page Start Address for Page Addressing Mode	Set GDDRAM Page Start Address (PAGE0~PAGE7) for Page Addressing Mode using X[2:0].
0	C0/C8	1	1	0	0	X ₃	0	0	0	Set COM Output Scan Direction	X[3]=0b: normal mode (RESET) Scan from COM0 to COM[N-1] X[3]=1b: remapped mode. Scan from COM[N-1] to COM0 Where N is the Multiplex ratio.
0 0	D3 A[5:0]	1 *	1 *	0 A ₅	1 A ₄	0 A ₃	0 A ₂	1 A ₁	1 A ₀	Set Display Offset	Set vertical shift by COM from 0~63. The value is reset to 00h after RESET.
0	D5 A[7:0]	1 A ₇	1 A ₆	0 A ₅	1 A ₄	0 A ₃	1 A ₂	0 A ₁	1 A ₀	Set Display Clock Divide Ratio/Oscillator Frequency	A[3:0] : Define the divide ratio (D) of the display clocks (DCLK): Divide ratio= A[3:0] + 1, RESET is 0000b (divide ratio = 1) A[7:4] : Set the Oscillator Frequency, F _{OSC} . Oscillator Frequency increases with the value of A[7:4] and vice versa. RESET is 0111b Range:0000b~1111b Frequency increases as setting value increases. Refer to section 10.1.23 for details.
0 0	D8	1 0	1 0	0 X ₅	1 X ₄	1 0	0 X ₂	0 0	0 X ₀	Set Area Color Mode ON/OFF & Low Power Display Mode	X[5:4]= 00b (RESET) : monochrome mode X[5:4]= 11b Area Color enable X[2]=0b and X[0]=0b: Normal power mode(RESET) X[2]=1b and X[0]=1b: Set low power display mode
0 0	D9 A[7:0]	1 A ₇	1 A ₆	0 A ₅	1 A ₄	1 A ₃	0 A ₂	0 A ₁	1 A ₀	Set Pre-charge Period	A[3:0] : Phase 1 period of up to 15 DCLK clocks (RESET=2h); 0 is invalid entry A[7:4] : Phase 2 period of up to 15 DCLK clocks (RESET=2h); 0 is invalid entry
0 0	DA	1 0	1 0	0 X ₅	1 X ₄	1 0	0 0	1 1	0 0	Set COM Pins Hardware Configuration	X[4]=0b, Sequential COM pin configuration X[4]=1b(RESET), Alternative COM pin configuration X[5]=0b(RESET), Disable COM Left/Right remap X[5]=1b, Enable COM Left/Right remap

Fundamental Command Table																							
D/C#	Hex	D7	D6	D5	D4	D3	D2	D1	D0	Command	Description												
0	DB	1	1	0	1	1	0	1	1	Set V _{COMH} Deselect Level	<table border="1"> <thead> <tr> <th>A[5:2]</th> <th>Hex code</th> <th>V_{COMH} deselect level</th> </tr> </thead> <tbody> <tr> <td>0000b</td> <td>00h</td> <td>~ 0.43 x V_{CC}</td> </tr> <tr> <td>1101b</td> <td>34h</td> <td>~ 0.77 x V_{CC} (RESET)</td> </tr> <tr> <td>1111b</td> <td>3Ch</td> <td>~ 0.83 x V_{CC}</td> </tr> </tbody> </table>	A[5:2]	Hex code	V _{COMH} deselect level	0000b	00h	~ 0.43 x V _{CC}	1101b	34h	~ 0.77 x V _{CC} (RESET)	1111b	3Ch	~ 0.83 x V _{CC}
A[5:2]	Hex code	V _{COMH} deselect level																					
0000b	00h	~ 0.43 x V _{CC}																					
1101b	34h	~ 0.77 x V _{CC} (RESET)																					
1111b	3Ch	~ 0.83 x V _{CC}																					
0	A[5:2]	0	0	A ₅	A ₄	A ₃	A ₂	0	0														
0	E0	1	1	1	0	0	0	0	0	Enter Read Modify Write	Enter the Read Modify Write mode. Details please refer to section 10.1.28.												
0	E3	1	1	1	0	0	0	1	1	NOP	Command for no operation												
0	EE	1	1	1	0	1	1	1	0	Exit Read Modify Write	Exit the Read Modify Write mode (Please refer to command E0h)												

Graphic Acceleration Command Table																																					
D/C#	Hex	D7	D6	D5	D4	D3	D2	D1	D0	Command	Description																										
00000	26/27	0	0	1	0	0	1	1	X ₀	Horizontal Scroll Setup	X[0]=0, Right Horizontal Scroll X[0]=1, Left Horizontal Scroll A[2:0] : Set number of column scroll offset 000b No horizontal scroll 001b Horizontal scroll by 1 column 010b Horizontal scroll by 2 columns 011b Horizontal scroll by 3 columns 100b Horizontal scroll by 4 columns Other values are invalid. B[2:0] : Define start page address <table border="1"> <tr> <td>000b – PAGE0</td> <td>011b – PAGE3</td> <td>110b – PAGE6</td> </tr> <tr> <td>001b – PAGE1</td> <td>100b – PAGE4</td> <td>111b – PAGE7</td> </tr> <tr> <td>010b – PAGE2</td> <td>101b – PAGE5</td> <td></td> </tr> </table> C[2:0] : Set time interval between each scroll step in terms of frame frequency <table border="1"> <tr> <td>000b – 6 frames</td> <td>100b – 3 frames</td> </tr> <tr> <td>001b – 32 frames</td> <td>101b – 4 frames</td> </tr> <tr> <td>010b – 64 frames</td> <td>110b – 2 frame</td> </tr> <tr> <td>011b – 128 frames</td> <td>111b – Invalid</td> </tr> </table> D[2:0] : Define end page address <table border="1"> <tr> <td>000b – PAGE0</td> <td>011b – PAGE3</td> <td>110b – PAGE6</td> </tr> <tr> <td>001b – PAGE1</td> <td>100b – PAGE4</td> <td>111b – PAGE7</td> </tr> <tr> <td>010b – PAGE2</td> <td>101b – PAGE5</td> <td></td> </tr> </table> The value of D[2:0] must be larger or equal to B[2:0]	000b – PAGE0	011b – PAGE3	110b – PAGE6	001b – PAGE1	100b – PAGE4	111b – PAGE7	010b – PAGE2	101b – PAGE5		000b – 6 frames	100b – 3 frames	001b – 32 frames	101b – 4 frames	010b – 64 frames	110b – 2 frame	011b – 128 frames	111b – Invalid	000b – PAGE0	011b – PAGE3	110b – PAGE6	001b – PAGE1	100b – PAGE4	111b – PAGE7	010b – PAGE2	101b – PAGE5	
000b – PAGE0	011b – PAGE3	110b – PAGE6																																			
001b – PAGE1	100b – PAGE4	111b – PAGE7																																			
010b – PAGE2	101b – PAGE5																																				
000b – 6 frames	100b – 3 frames																																				
001b – 32 frames	101b – 4 frames																																				
010b – 64 frames	110b – 2 frame																																				
011b – 128 frames	111b – Invalid																																				
000b – PAGE0	011b – PAGE3	110b – PAGE6																																			
001b – PAGE1	100b – PAGE4	111b – PAGE7																																			
010b – PAGE2	101b – PAGE5																																				
00000	A[2:0]	*	*	*	*	*	A ₂	A ₁	A ₀																												
00000	B[2:0]	*	*	*	*	*	B ₂	B ₁	B ₀																												
00000	C[2:0]	*	*	*	*	*	C ₂	C ₁	C ₀																												
00000	D[2:0]	*	*	*	*	*	D ₂	D ₁	D ₀																												
00000	29/2A	0	0	1	0	1	0	X ₁	X ₀	Continuous Vertical and Horizontal Scroll Setup	X ₁ X ₀ =01b : Vertical and Right Horizontal Scroll X ₁ X ₀ =10b : Vertical and Left Horizontal Scroll A[2:0] : Set number of column scroll offset 000b No horizontal scroll 001b Horizontal scroll by 1 column 010b Horizontal scroll by 2 columns 011b Horizontal scroll by 3 columns 100b Horizontal scroll by 4 columns Other values are invalid. B[2:0] : Define start page address <table border="1"> <tr> <td>000b – PAGE0</td> <td>011b – PAGE3</td> <td>110b – PAGE6</td> </tr> <tr> <td>001b – PAGE1</td> <td>100b – PAGE4</td> <td>111b – PAGE7</td> </tr> <tr> <td>010b – PAGE2</td> <td>101b – PAGE5</td> <td></td> </tr> </table> C[2:0] : Set time interval between each scroll step in terms of frame frequency <table border="1"> <tr> <td>000b – 6 frames</td> <td>100b – 3 frames</td> </tr> <tr> <td>001b – 32 frames</td> <td>101b – 4 frames</td> </tr> <tr> <td>010b – 64 frames</td> <td>110b – 2 frame</td> </tr> <tr> <td>011b – 128 frames</td> <td>111b – Invalid</td> </tr> </table> D[2:0] : Define end page address <table border="1"> <tr> <td>000b – PAGE0</td> <td>011b – PAGE3</td> <td>110b – PAGE6</td> </tr> <tr> <td>001b – PAGE1</td> <td>100b – PAGE4</td> <td>111b – PAGE7</td> </tr> <tr> <td>010b – PAGE2</td> <td>101b – PAGE5</td> <td></td> </tr> </table> The value of D[2:0] must be larger or equal to B[2:0] E[5:0] : Vertical scrolling offset e.g. E[5:0]= 01h refer to offset =1 row E[5:0] =3Fh refer to offset =63 rows	000b – PAGE0	011b – PAGE3	110b – PAGE6	001b – PAGE1	100b – PAGE4	111b – PAGE7	010b – PAGE2	101b – PAGE5		000b – 6 frames	100b – 3 frames	001b – 32 frames	101b – 4 frames	010b – 64 frames	110b – 2 frame	011b – 128 frames	111b – Invalid	000b – PAGE0	011b – PAGE3	110b – PAGE6	001b – PAGE1	100b – PAGE4	111b – PAGE7	010b – PAGE2	101b – PAGE5	
000b – PAGE0	011b – PAGE3	110b – PAGE6																																			
001b – PAGE1	100b – PAGE4	111b – PAGE7																																			
010b – PAGE2	101b – PAGE5																																				
000b – 6 frames	100b – 3 frames																																				
001b – 32 frames	101b – 4 frames																																				
010b – 64 frames	110b – 2 frame																																				
011b – 128 frames	111b – Invalid																																				
000b – PAGE0	011b – PAGE3	110b – PAGE6																																			
001b – PAGE1	100b – PAGE4	111b – PAGE7																																			
010b – PAGE2	101b – PAGE5																																				
00000	A[2:0]	*	*	*	*	*	A ₂	A ₁	A ₀																												
00000	B[2:0]	*	*	*	*	*	B ₂	B ₁	B ₀																												
00000	C[2:0]	*	*	*	*	*	C ₂	C ₁	C ₀																												
00000	D[2:0]	*	*	*	*	*	D ₂	D ₁	D ₀																												
00000	E[5:0]	*	*	E ₅	E ₄	E ₃	E ₂	E ₁	E ₀																												

Graphic Acceleration Command Table											
D/C#	Hex	D7	D6	D5	D4	D3	D2	D1	D0	Command	Description
0	2E	0	0	1	0	1	1	1	0	Deactivate scroll	<p>Stop scrolling that is configured by command 26h/27h/29h/2Ah.</p> <p>Note ⁽¹⁾ After sending 2Eh command to deactivate the scrolling action, the ram data needs to be rewritten.</p>
0	2F	0	0	1	0	1	1	1	1	Activate scroll	<p>Start scrolling that is configured by the scrolling setup commands :26h/27h/29h/2Ah with the following valid sequences: Valid command sequence 1: 26h ;2Fh. Valid command sequence 2: 27h ;2Fh. Valid command sequence 3: 29h ;2Fh. Valid command sequence 4: 2Ah ;2Fh.</p> <p>For example, if “26h; 2Ah; 2Fh.” commands are issued, the setting in the last scrolling setup command, i.e. 2Ah in this case, will be executed. In other words, setting in the last scrolling setup command overwrites the setting in the previous scrolling setup commands.</p>
0 0 0	A3 A[5:0] B[6:0]	1 * *	0 * B ₆	1 A ₅ B ₅	0 A ₄ B ₄	0 A ₃ B ₃	0 A ₂ B ₂	1 A ₁ B ₁	1 A ₀ B ₀	Set Vertical Scroll Area	<p>A[5:0] : Set No. of rows in top fixed area. The No. of rows in top fixed area is referenced to the top of the GDDRAM(i.e. row 0).[RESET = 0]</p> <p>B[6:0] : Set No. of rows in scroll area. This is the number of rows to be used for vertical scrolling. The scroll area starts in the first row below the top fixed area. [RESET = 64]</p> <p>Note ⁽¹⁾ A[5:0]+B[6:0] <= MUX ratio ⁽²⁾ B[6:0] <= MUX ratio ^(3a) Vertical scrolling offset (E[5:0] in 29h/2Ah) < B[6:0] ^(3b) Set Display Start Line (X5X4X3X2X1X0 of 40h~7Fh) < B[6:0] ⁽⁴⁾ The last row of the scroll area shifts to the first row of the scroll area. ⁽⁵⁾ For 64d MUX display A[5:0] = 0, B[6:0]=64 : whole area scrolls A[5:0]= 0, B[6:0] < 64 : top area scrolls A[5:0] + B[6:0] < 64 : central area scrolls A[5:0] + B[6:0] = 64 : bottom area scrolls Please refer to Figure 10-14 for details.</p>

Note

⁽¹⁾ “*” stands for “Don’t care”.

Read Command Table

Bit Pattern	Command	Description
D ₇ D ₆ D ₅ D ₄ D ₃ D ₂ D ₁ D ₀	Status Register Read	D[7] : Reserve D[6] : “1” for display OFF / “0” for display ON D[5] : Reserve D[4] : Reserve D[3] : Reserve D[2] : Reserve D[1] : Reserve D[0] : Reserve

Note

⁽¹⁾ Patterns other than those given in the Command Table are prohibited to enter the chip as a command; as unexpected results can occur.

■ INITIALIZATION CODE (初始化代码)

```
void InitOLED_MASTER_SSD1305(void)
{
    Write_Command(0xAE);           // Display Off (0x00/0x01)

    Write_Command(0xD5);           // Set Display Clock Divide Ratio / Oscillator Frequency
    Write_Command(0xA0);           // Set Clock as A0 Frames/Sec

    Write_Command(0xA8);           // Set Multiplex Ratio
    Write_Command(0X1F);           // 1/32 Duty (0x0F~0x1F)

    Write_Command(0xD3);           // Set Display Offset
    Write_Command(0X00);           // Shift Mapping RAM Counter (0x00~0x3F)

    Write_Command(0x40);           // Set Mapping RAM Display Start Line (0x00~0x3F)

    Write_Command(0xAD);           // Set Master Configuration
    Write_Command(0x8E);           // Disable Embedded DC/DC Converter (0x00/0x01)

    Write_Command(0xD8);           // Set Area Color Mode On/Off & Low Power Display Mode
    Write_Command(0x05);           // Set Monochrome & Low Power Save Mode
    Write_Command(0xA1);           // Set SEG/Column Mapping (0x00/0x01)

    Write_Command(0xC8);           // Set COM/Row Scan Direction (0x00/0x08)

    Write_Command(0xDA);           // Set COM Pins Hardware Configuration
    Write_Command(0x12);           // Set Alternative Configuration (0x00/0x10)

    Write_Command(0x91);           // Define Look Up Table of Area Color
    Write_Command(0X3F);           // Define Bank 0 Pulse Width
    Write_Command(0X3F);           // Define Color A Pulse Width
    Write_Command(0X3F);           // Define Color B Pulse Width
    Write_Command(0X3F);           // Define All Banks Pulse Width as 64 Clocks

    Write_Command(0x81);           // Set Contrast Control for Bank 0
    Write_Command(0X6F);           // Set SEG Output Current

    Write_Command(0xD9);           // Set Pre-Charge Period
    Write_Command(0x43);           // Set Pre-Charge as 13 Clocks & Discharge as 2 Clock
```

```
Write_Command(0xDB);           // Set VCOMH Deselect Level
Write_Command(0x2C);

Write_Command(0xA4);           // Disable Entire Display On (0x00/0x01)
Write_Command(0xA6);           // Disable Inverse Display On (0x00/0x01)

DispAllOff();

    Write_Command(0xAF);        // Display On (0x00/0x01)
}
```

Note:

Please set appropriate parameters of initialization based on actual application.

注意：请基于实际的应用程序设置合适的初始化的参数。

■ SCHEMATIC EXAMPLE (应用电路)

◆ 8080 Series Interface Application Circuit

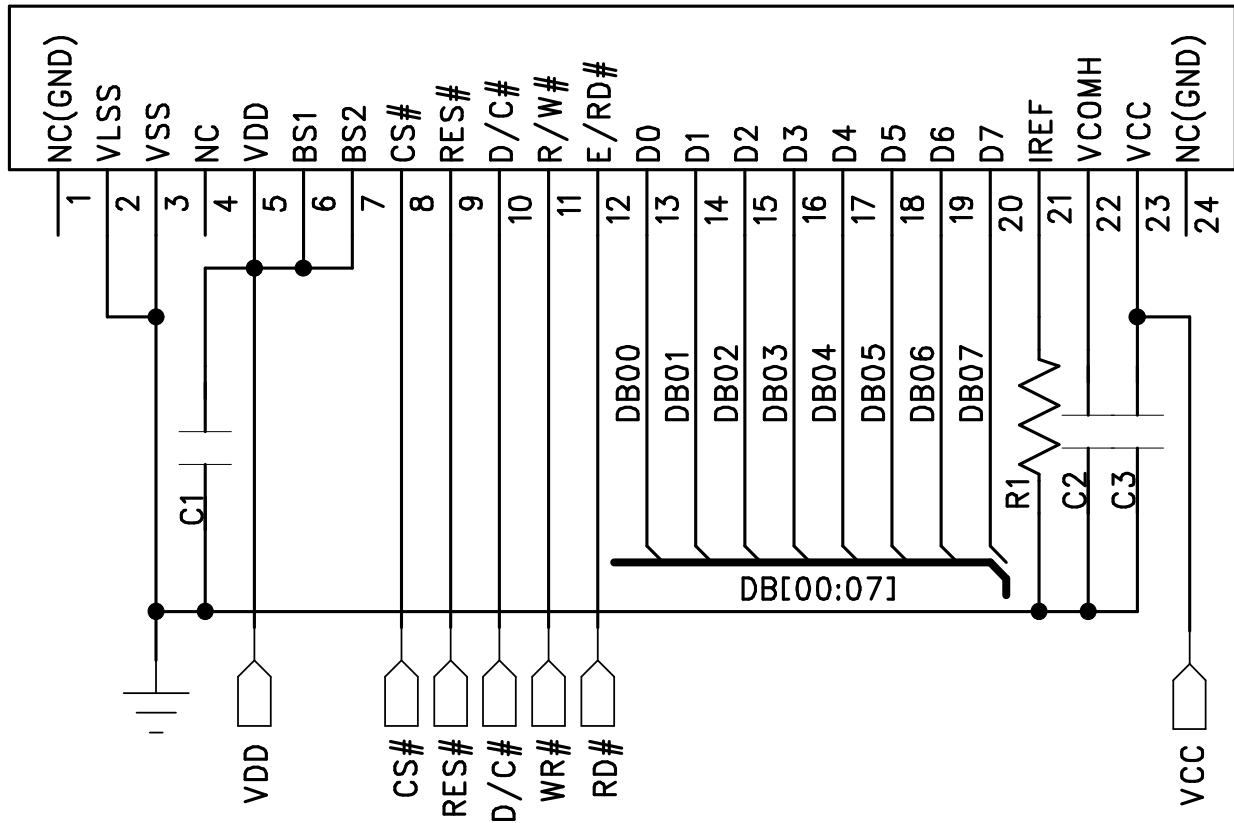

NOTE:

1. $R1 = (V_{CC} - 3)V / 10\mu A = (12.5 - 3)V / 10\mu A = 950K\Omega$,
 $C1 = C2 = C3 = 4.7\mu F$.
2. The VCC should connect an external voltage.
 VCC 应连接到外部电压。
3. The capacitor and the resistor value are recommended value. Select the appropriate value against module application.
 电容和电阻的值仅为推荐的值，根据模块的实际应用选择合适的值。

◆ 6800 Series Interface Application Circuit

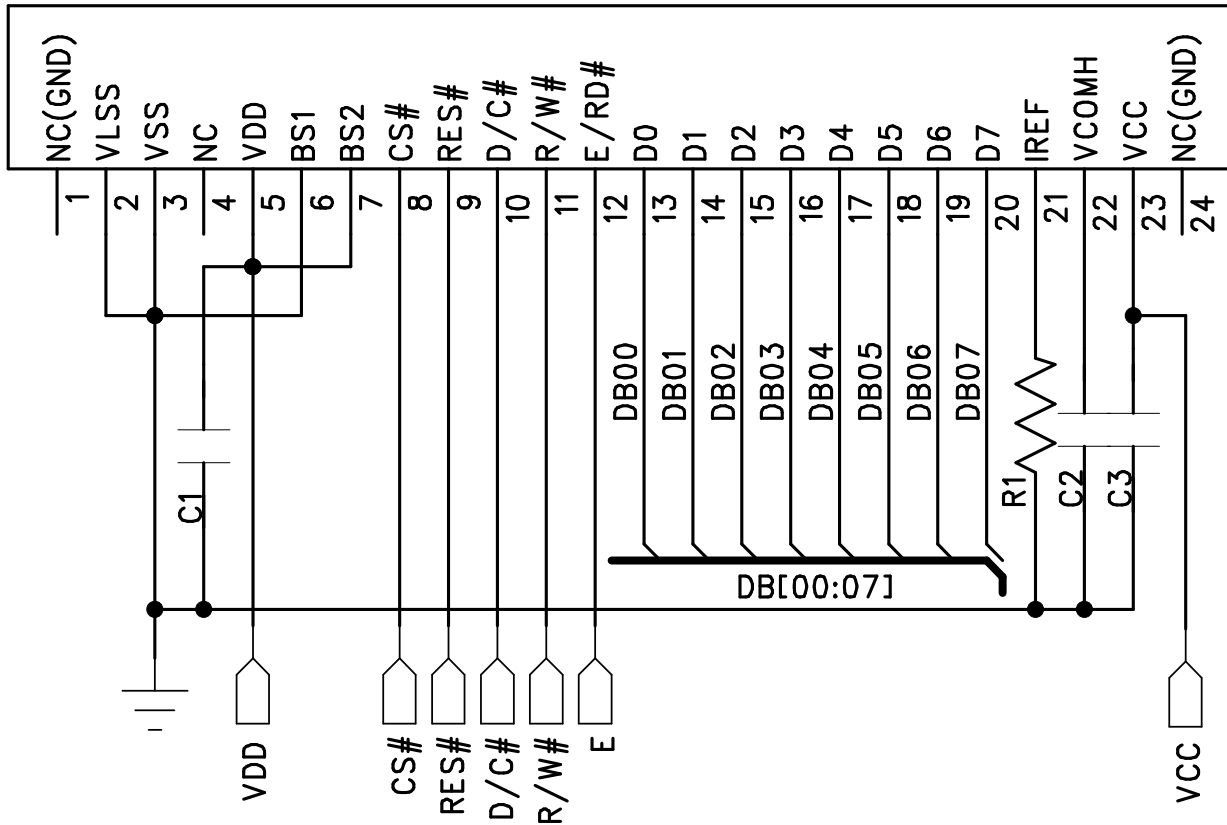

NOTE:

1. $R1 = (V_{CC} - 3)V / 10\mu A = (12.5 - 3)V / 10\mu A = 950K\Omega$,
 $C1 = C2 = C3 = 4.7\mu F$.
2. The VCC should connect an external voltage.
 VCC 应连接到外部电压。
3. The capacitor and the resistor value are recommended value. Select the appropriate value against module application.
 电容和电阻的值仅为推荐的值，根据模块的实际应用选择合适的值。

◆ SPI Series Interface Application Circuit

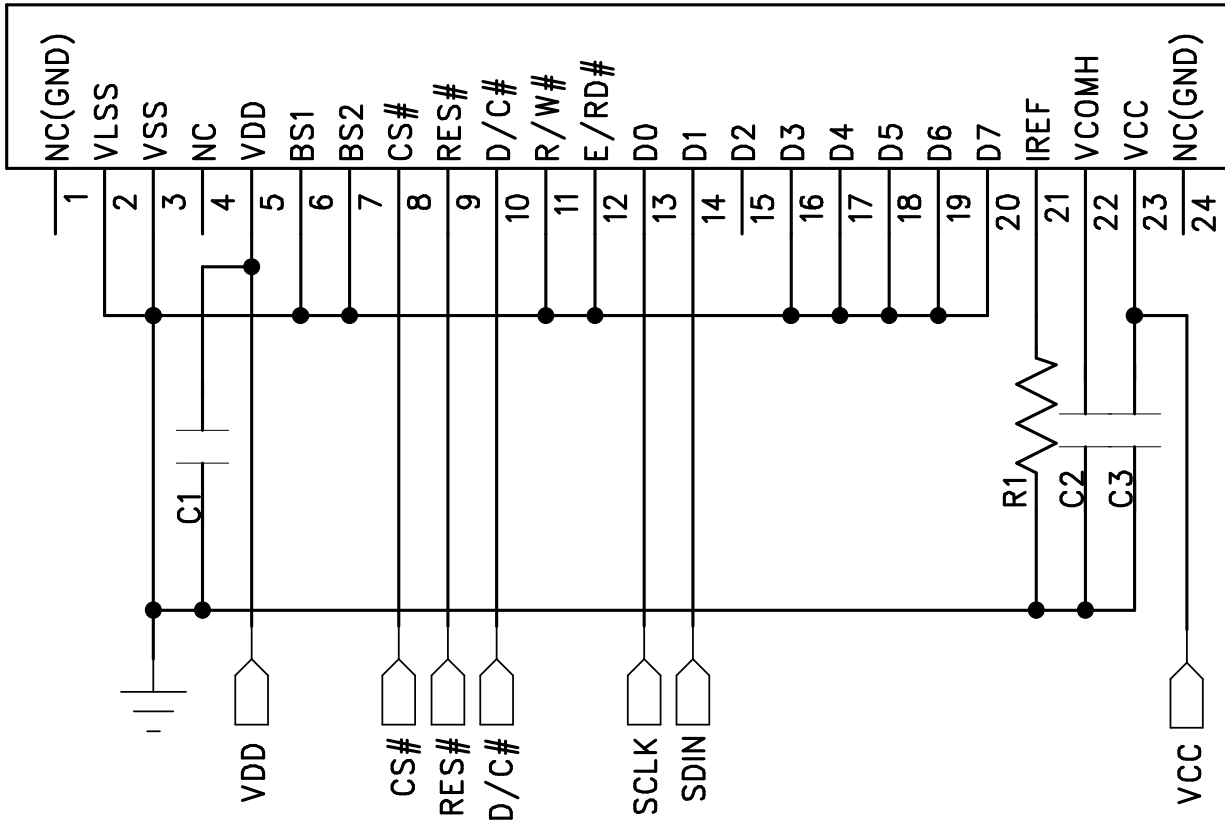

NOTE:

1. $R1=(V_{CC}-3)V/10\mu A=(12.5-3)V/10\mu A=950K\Omega$,
 $C1=C2=C3=4.7\mu F$.
2. The VCC should connect an external voltage.
 VCC 应连接到外部电压。
3. In SPI, the read function is not possible
 在 SPI 模式中无法读取。
4. The capacitor and the resistor value are recommended value. Select the appropriate value against module application.
 电容和电阻的值仅为推荐的值，根据模块的实际应用选择合适的值。

◆ I²C Series Interface Application Circuit

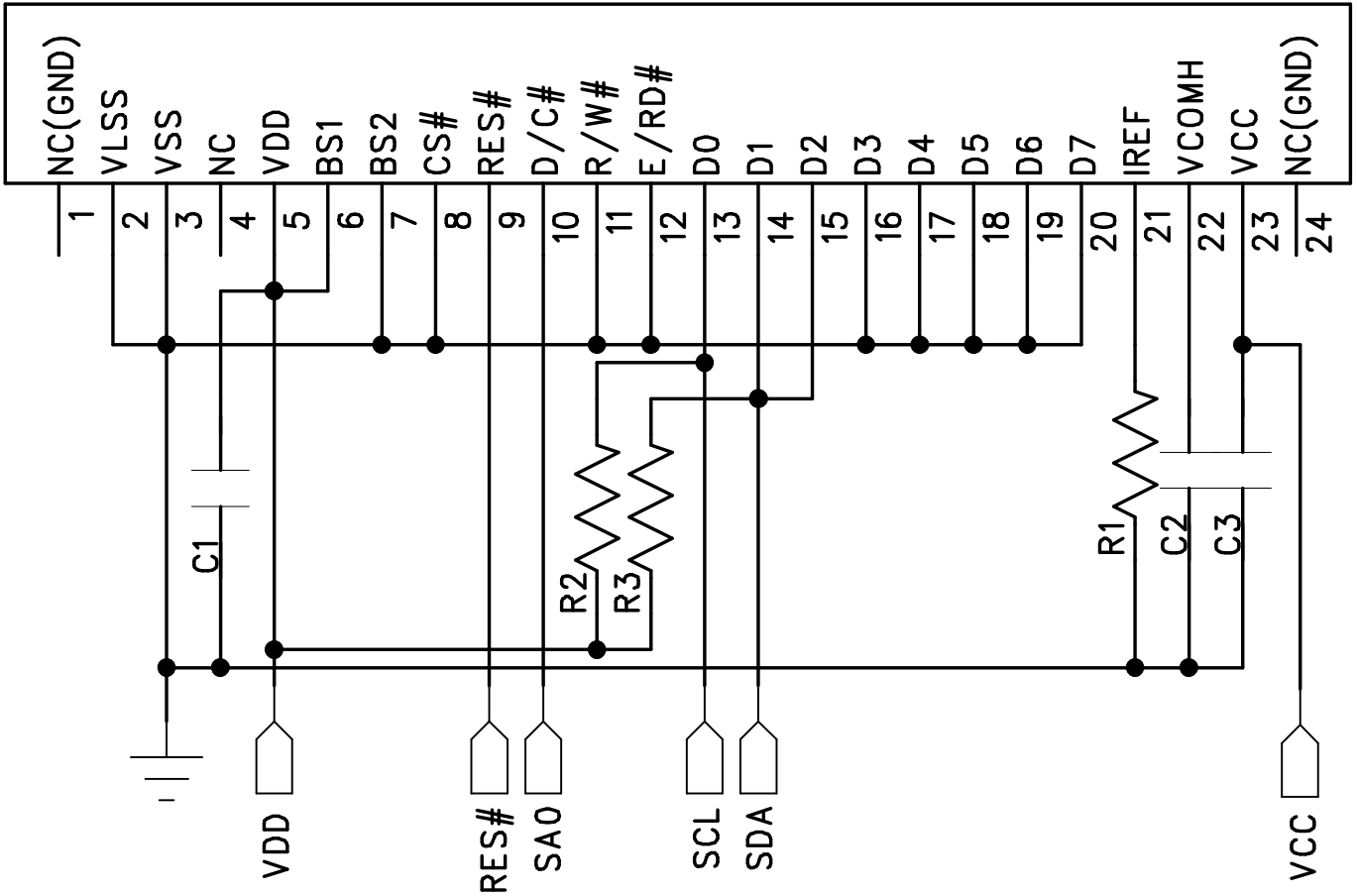

NOTE:

1. $R1=(V_{CC}-3)V/10\mu A=(12.5-3)V/10\mu A=950K\Omega$,
 $R2=R3=10K\Omega$, pull-up resistance.
 $C1=C2=C3=4.7\mu F$.
2. The VCC should connect an external voltage.
 VCC 应连接到外部电压。
3. In SPI, the read function is not possible
 在 SPI 模式中无法读取。
4. The capacitor and the resistor value are recommended value. Select the appropriate value against module application.
 电容和电阻的值仅为推荐的值，根据模块的实际应用选择合适的值。

■ RELIABILITY TESTS (可靠性测试)

NO.	Item	Condition	Quantity
1	High Temperature Storage (HTS)	85±2℃, 200 hours	3
2	High Temperature Operating (HTO)	80±2℃, 96 hours	3
3	Low Temperature Storage (LTS)	-40±2℃, 200 hours	3
4	Low Temperature Operating (LTO)	-30±2℃, 96 hours	3
5	High Temperature / High Humidity Storage (HTHHS)	50±3℃, 90% ±3%RH, 120 hours	3
6	Thermal Shock (Non-operation) (TS)	-20±2℃ ~ 25℃ ~ 70±2℃ (30min) (5min) (30min) 10cycles	3
7	Vibration (Packing)	10~55~10Hz, amplitude 1.5mm, 1 hour for each direction x, y, z	1 Carton
8	Drop (Packing)	Height : 1 m, each time for 6 sides, 3 edges, 1 angle	1 Carton
9	ESD (finished product housing)	±4kVR:330Ω; C:150pF 10times, air discharge	3

Test and measurement conditions (测试与测量条件)

1. All measurements shall not be started until the specimens attain to temperature stability.
2. The degradation of Polarizer are ignored for item 1, 2 & 5.

Evaluation criteria (评估标准)

1. The function test is ok.
2. No addition to the defect.
3. The change of luminance should be within ±50% of initial value.
4. The change for the color must be within (±0.02)of initial value based on 1931 CIE coordinates.
5. The change of total current consumption should be within ±50% of initial value.
6. In case of malfunction or defect caused by ESD damage, it would be judged as a good part if it would be recovered to normal state after resetting.

■ OUTGOING QUALITY CONTROL SPECIFICATION (出厂质量控制规范)

◆ Standard (标准)

According to GB/T2828.1-2003/ISO 2859-1: 1999 and ANSI/ASQC Z1.4-1993, General Inspection Level II.

◆ Definition (定义)

1. Major defect: The defect that greatly affect the usability of product.
2. Minor defect: The other defects, such as cosmetic defects, etc.
3. Definition of inspection zone: _____

Zone A: Active Area

Zone B: Viewing Area except Zone A

Zone C: Outside Viewing Area

Note: As a general rule, visual defects in Zone C are permissible, when it is no trouble of quality and assembly to customer`s product.

◆ Inspection Methods (检查方法)

1. The general inspection: under 20W x 2 or 40W fluorescent light, about 30cm viewing distance, within 45 °viewing angle, under 25 ±5 °C.

2. The luminance and color coordinate inspection: By CS2000/09A-OLED-117 or the equal equipment, in the dark room, under 25 ±5 °C.

◆ **Inspection Criteria (检查标准)**

1. Major defect: AQL= 0.65

Item	Criterion
Function Defect	1. No display or abnormal display is not accepted
	2. Open or short is not accepted.
	3. Power consumption exceeding the spec is not accepted.
Outline Dimension	Outline dimension exceeding the spec is not accepted.
2. Minor Defect: AQL= 1.5	
Glass Crack	Glass crack tends to enlarge is not accepted.

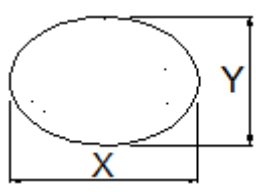
Spot Defect (dimming and lighting spot)	Size (mm)		Accepted Qty.	
		$\Phi \leq 0.10$	Area A + Area B	Area C
		$0.10 < \Phi \leq 0.15$	Ignored	
		$0.15 < \Phi \leq 0.2$	3	Ignored
		$0.2 < \Phi$	1	
Note : $\Phi = (x + y) / 2$		0		

Line Defect (dimming and lighting line)	L (Length) : mm	W (Width) : mm	Area A + Area B	Area C
	/	$W \leq 0.02$	Ignored	
	$L \leq 3.0$	$0.02 < W \leq 0.03$	2	Ignored
	$L \leq 2.0$	$0.03 < W \leq 0.05$	1	
	/	$0.05 < W$	As spot defect	

Remarks: The total of spot defect and line defect shall not exceed 4 PCS. The distance between two lines defects must exceed 1 mm

Polarizer Stain
Stain which can be wiped off lightly with a soft cloth or similar cleaning is accepted, otherwise, according to the Spot Defect and the Line Defect.

Polarizer Scratch	1. If scratch can be seen during operation, according to the criterions of the Spot Defect and the Line Defect.			
	2. If scratch can be seen only under non-operation or some special angle, the criterion is as below:			
	L (Length) : mm	W (Width) : mm	Area A + Area B	Area C
	/	$W \leq 0.02$	Ignore	
	$3.0 < L \leq 5.0$	$0.02 < W \leq 0.04$	2	Ignore
	$L \leq 3.0$	$0.04 < W \leq 0.06$	1	
/	$0.06 < W$	0		

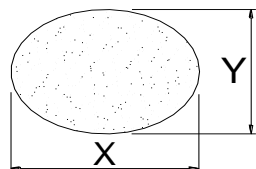
Polarizer Air Bubble	Size		Area A + Area B	Area C
		$\Phi \leq 0.20$	Ignored	
		$0.20 < \Phi \leq 0.30$	2	Ignored
		$0.30 < \Phi \leq 0.50$	1	
		$0.50 < \Phi$	0	

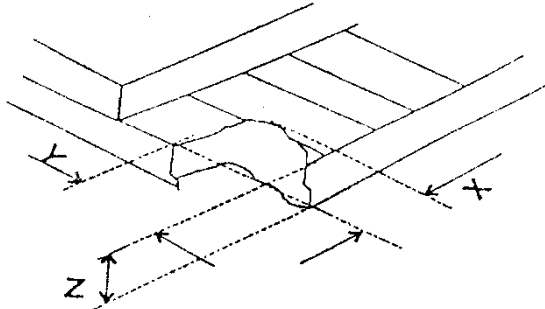
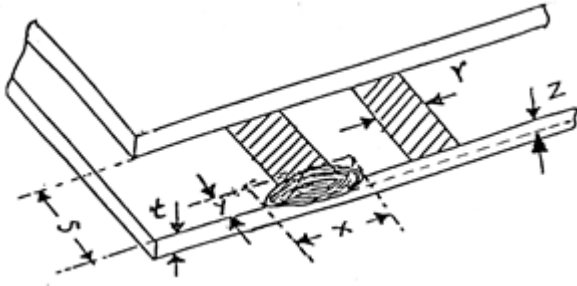
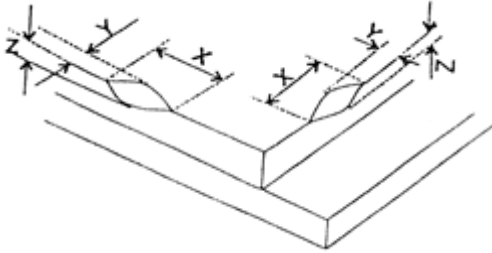
Glass Defect (Glass Chipped)	1. On the corner (mm)	 <table border="1" data-bbox="1093 479 1422 667"> <tr> <td>x</td> <td>≤ 1.5</td> </tr> <tr> <td>y</td> <td>≤ 1.5</td> </tr> <tr> <td>z</td> <td>$\leq t$</td> </tr> </table>	x	≤ 1.5	y	≤ 1.5	z	$\leq t$
	x	≤ 1.5						
	y	≤ 1.5						
	z	$\leq t$						
2. On the bonding edge (mm)	 <table border="1" data-bbox="1093 882 1422 1070"> <tr> <td>x</td> <td>$\leq a/4$</td> </tr> <tr> <td>y</td> <td>$\leq s/3 \ \&\leq 0.7$</td> </tr> <tr> <td>z</td> <td>$\leq t$</td> </tr> </table>	x	$\leq a/4$	y	$\leq s/3 \ \&\leq 0.7$	z	$\leq t$	
x	$\leq a/4$							
y	$\leq s/3 \ \&\leq 0.7$							
z	$\leq t$							
3. On the other edges (mm)	 <table border="1" data-bbox="1093 1252 1422 1440"> <tr> <td>x</td> <td>$\leq a / 8$</td> </tr> <tr> <td>y</td> <td>≤ 0.7</td> </tr> <tr> <td>z</td> <td>$\leq t$</td> </tr> </table>	x	$\leq a / 8$	y	≤ 0.7	z	$\leq t$	
x	$\leq a / 8$							
y	≤ 0.7							
z	$\leq t$							
Note: t: glass thickness; s: pad width; a: the length of the edge.								
TCP Defect	Crack, deep fold and deep pressure mark on the TCP are not accepted							
Pixel Size	The tolerance of display pixel dimension should be within $\pm 20\%$ of the spec.							
Luminance	Refer to the spec or the reference sample.							
Color	Refer to the spec or the reference sample.							

■ CAUTIONS IN USING OLED MODULE (OLED 模块使用注意事项)

◆ Precautions for Handling OLED Module (处理 OLED 模块的注意事项):

1. The display panel is made of glass and polarizer. As glass is fragile. It tends to become chipped during handling especially on the edges. Please avoid dropping or jarring. Do not subject it to a mechanical shock by dropping it or impact.

显示屏由玻璃和偏光片组成。由于玻璃是脆弱的，使用过程中要特别防止边缘区损伤。请避免显示屏因跌落或振动而受到机械冲击。

2. Do not apply excessive force to the display surface or the adjoining areas since this may cause abnormal. Do not touch the display with bare hands. This will stain the display area (some cosmetics are determined to the polarizer).

请勿施加过大的压力于显示屏或连接部位，否则可能会引起显示异常。不要用手接触显示屏，这将弄脏显示区（一些外观是由偏光片决定的）。

3. The polarizer covering the display surface of the OLED module is soft and easily scratched. Handle this polarizer carefully. Do not touch, push or rub the exposed polarizers with anything harder than an HB pencil lead (glass, tweezers, etc.). Do not put or attach anything on the display area to avoid leaving marks on it. Condensation on the surface and contact with terminals due to cold will damage, stain or dirty the polarizer. After products are tested at low temperature they must be warmed up in a container before coming in to contact with room temperature air.

覆盖 OLED 显示模块显示平面的偏光片是软性的且易被擦伤，请小心，轻拿。请勿用任何硬度大于 HB 铅笔芯的物品（玻璃，镊子等）接触、撞压或摩擦裸露偏光片。不要放置或粘附物体在显示区域上以免留下痕迹。冷凝在表面和端子将会损坏或弄脏偏光片。产品在低温下测试之后，与室温空气接触之前必须在容器内升温。

4. If the display surface becomes contaminated, breathe on the surface and gently wipe it with a soft dry cloth. If it is heavily contaminated, moisten cloth with one of the following solvents.

- Isopropyl alcohol
- Ethyl alcohol

Do not scrub hard to avoid damaging the display surface.

如果显示平面受污，可对平面吹热气且轻轻地用软性干布擦除。如果受污严重，用含下列一种溶剂的湿布擦除：

- 甘油
- 酒精

请勿用力擦拭以免损坏显示平面。

5. Solvents other than those above-mentioned may damage the polarizer. Especially, do not use the following.

- Water
- Ketone
- Aromatic solvents

Wipe off saliva or water drops immediately, contact with water over a long period of time may cause deformation or color fading. Avoid contact with oil and fats.

除以上提到的溶剂外，其他溶剂可能会损坏偏光片，特别要避免使用以下溶剂：

- 水
- 酮
- 芳烃溶剂

立即擦掉唾液或水滴，长时间与水接触会引起变形或褪色。避免接触油和油脂。

6. Exercise care to minimize corrosion of the electrode. Corrosion of the electrodes is accelerated by water droplets, moisture condensation or a current flow in a high-humidity environment.

特别注意最小限度地减少电极腐蚀，电极腐蚀会因水滴、湿度冷凝或高湿环境下通电而加速。

-
-
7. When mounting the OLED module make sure it is free of twisting, warping and distortion. In particular, do not forcibly pull or bend the I/O cable.
安装 OLED 模块时一定不要弯曲、扭曲和变形。要特别注意不要用力拔，弯曲传输线。
 8. Do not attempt to disassemble or process the OLED module.
请勿拆卸 OLED 模块。
 9. NC terminal should be open. Do not connect anything.
悬空端应断开，不要连接任何器件。
 10. If the logic circuit power is off, do not apply the input signals.
如果逻辑电路电源是断开的，不要施加输入信号。
 11. Electro-Static Discharge Control, Since this module uses a CMOS LSI, the same careful attention should be paid to electrostatic discharge as for an ordinary CMOS IC. To prevent destruction of the elements by static electricity, be careful to maintain an optimum work environment.
由于 OLED 显示模块使用 CMOS 集成，要特别注意静电放电问题。对 CMOS 器件，要特别注意静电。为防止静电造成的损坏，注意保持合宜的工作环境。
 - Before removing OLED from its packing case or incorporating it into a set, be sure the module and your body have the same electric potential. Be sure to ground the body when handling the OLED modules.
- OLED 模块移出包装盒和安装之前，要保证模块和人体具有相同的电位。处理模块时可靠接地。
 - Tools required for assembling, such as soldering irons, must be properly grounded. Make certain the AC power source for the soldering iron does not leak. When using an electric screwdriver to attach LCM, the screwdriver should be of ground potentiality to minimize as much as possible any transmission of electromagnetic waves produced sparks coming from the commutator of the motor.
- 使用工具如电烙铁，必须正确接地，并确保烙铁使用的交流电不会漏电。用电动螺丝刀固定模块时，电动螺丝刀应接地，尽可能降低电动换向器火花产生的电磁波。
 - To reduce the amount of static electricity generated, do not conduct assembling and other work under dry conditions. To reduce the generation of static electricity be careful that the air in the work is not too dry. A relative humidity of 50%-60% is recommended. As far as possible make the electric potential of your work clothes and that of the work bench the ground potential.
- 为减少静电产生，不要在干燥的条件下进行组装等工作。为降低静电，工作环境一定不要干燥。建议相对湿度为 50%-60%。尽可能使你的工作服和工作台接地。
 - The OLED module is coated with a film to protect the display surface. Exercise care when peeling off this protective film since static electricity may be generated.
- OLED 模块表面有保护膜。需要小心操作因为撕保护膜时可能产生静电。

12. OLED module is easy to be damaged. Please note below and be careful for handling.
 OLED 显示模块很容易被损坏. 请注意以下并小心操作

i. Correct handling (正确操作):

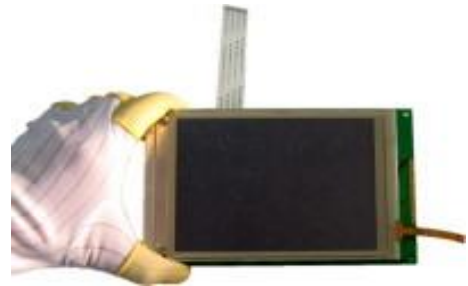

As above picture, please handle with anti-static gloves around OLED module edges.
 像上面的图片,请戴抗静电手套,并拿模块边缘.

ii. Incorrect handling(错误操作):



Please don't touch IC directly.
 不要直接地触摸 IC

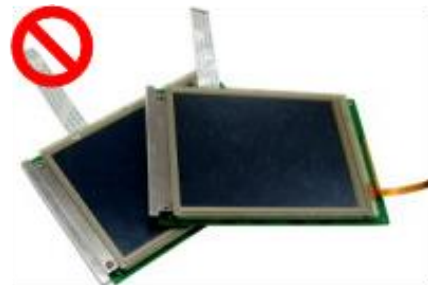

Please don't stack LCM.
 不要把模块叠在一起



Please don't hold the surface of panel.
 请不要拿着面板的表面



Please don't stretch interface of output,
 such as FPC cable.
 请不要拉扯输出接口,如接口线



Please don't hold the surface of IC.
 请不要拿着 IC 的表面

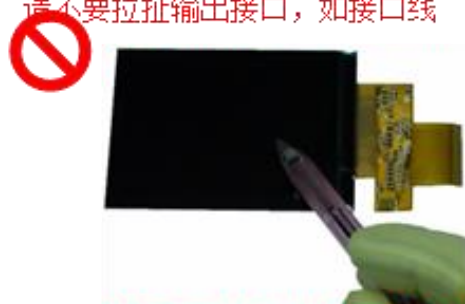

Please don't operate with sharp stick such as pens.
 请不要用尖锐的物体来操作,例如用笔尖

◆ Precautions for Storing OLED Module (OLED 模块存储注意事项)

1. When storing the OLED modules, the following precautions are necessary.

OLED 模块的存储依照以下几点:

- i. Store them in a sealed polyethylene bag with the desiccant.
使用干燥剂和聚乙烯袋密封包装。
 - ii. Store them in a dark place. Do not expose to sunlight or fluorescent light, keep the temperature between 0°C and 35°C, and keep the relative humidity between 40%RH and 60%RH.
避光保存, 避免直接暴露在太阳光或黄光灯下, 保持温度在 0~35 摄氏度之间, 保持相对湿度在 40%RH 和 60%RH 之间。
 - iii. The polarizer surface should not come in contact with any other objects (We advise you to store them in the anti-static electricity container in which they were shipped).
偏光片表面避免接触其他物质 (建议存放在货运防静电包装中)。
2. Others
- i. If the OLED modules have been operating for a long time, it will cause brightness decay. It is not recommended to show the same display patterns for a long time, otherwise the display patterns may remain on the screen as ghost images and it is unrecoverable.
OLED 长时间点亮会有亮度衰减, 所以尽量避免长时间工作于同一个显示图案, 否则会造成鬼影, 这是不可恢复的。
 - ii. To minimize the performance degradation of the OLED modules resulting from destruction caused by static electricity etc., exercise care to avoid holding the following sections when handling the modules.
为最小限度地降低由静电等导致 OLED 模块性能降低, 使用模块时慎重使用下列区域:
 - Exposed area of the printed circuit board.
印制电路板裸露区域。
 - Terminal electrode sections.
印制电路板引出端子区域。

◆ **Using OLED Modules (OLED 模块使用注意事项)**

Installing OLED Modules (安装 OLED 模块)

- i. When assembling the OLED module into other equipment, the spacer to the bit between the OLED module and the fitting plate should have enough height to avoid causing stress to the module surface, refer to the individual specifications for measurements. The measurement tolerance should be $\pm 0.1\text{mm}$.

将 OLED 模块安装进入其它设备时，模块和安装板之间间隔应有足够的高度以避免模块表面受压。参照专业度量技术标准。量度公差应是 ± 0.1 毫米。

- ii. Precaution for assemble the module with BTB connector:

用板对板连接器安装 OLED 显示模块注意事项:

Please note the position of the male and female connector position, don't assemble or assemble like the method which the following picture shows.

请注意连接器的公母及连接位置，请勿出现下图所示的连接方式。

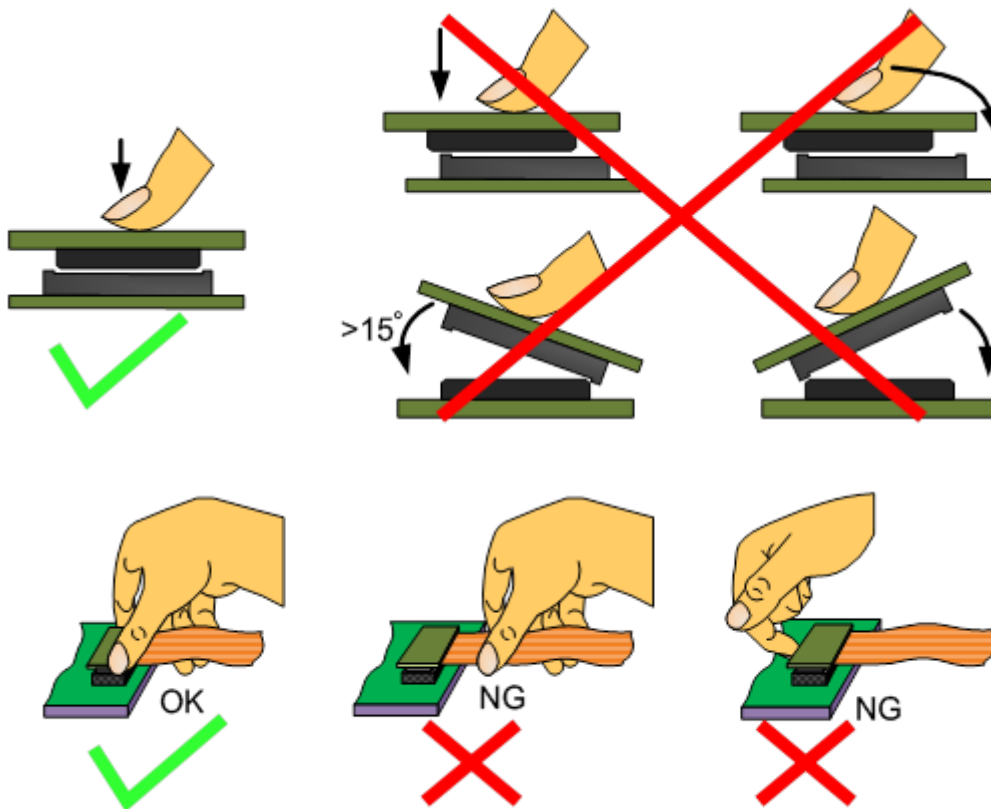

◆ **Precautions for Soldering OLED Module (OLED 模块焊接注意事项)**

	Manual soldering 手工焊接	Machine drag soldering 机器拖焊	Machine press soldering 机器压焊
No RoHS Product 非环保产品	290°C ~350°C. Time: 3-5S.	330°C ~350°C. Speed : 15-17 mm/s.	300°C ~330°C. Time: 3-6S. Press: 0.8~1.2Mpa
RoHS Product 环保产品	340°C ~370°C. Time: 3-5S.	350°C ~370°C. Speed : 15-17 mm/s.	330°C ~360°C. Time: 3-6S. Press: 0.8~1.2Mpa

1. If soldering flux is used, be sure to remove any remaining flux after finishing to soldering operation (This does not apply in the case of a non-halogen type of flux). It is recommended that you protect the OLED surface with a cover during soldering to prevent any damage due to flux spatters.
如果使用助焊剂，完成焊接后一定要清除剩余的助焊剂（除非卤化物助焊剂）。建议焊接时用盖子保护显示屏面以避免因助焊剂溅出造成的任何损坏。
2. When soldering the OLED module and PC board, the panel and board should not be detached more than three times. This maximum number is determined by the temperature and time conditions mentioned above, though there may be some variance depending on the temperature of the soldering iron.
焊接 OLED 模块和线路板时，不应装卸多于三次。尽管焊接温度会有变化，但不应超过上面提到的焊接温度和时间最大值。
3. When remove the OLED module from the PC board, be sure the solder has completely melted, the soldered pad on the PC board could be damaged.
从线路板上移除 OLED 模块时，要保证焊锡已完全熔化，不要损坏线路板上的焊接位。

◆ **Precautions for Operation (工作运行注意事项:)**

1. OLED is a self-light device, do not use back character on a white background display mode, otherwise the power consumption will be higher and it will cause crosstalk.
OLED 是自发光器件, 不要使用白底黑字显示模式, 否则功耗增大, 并且会有交叉效应。
2. It is an indispensable condition to drive OLED's within the specified voltage limit since the higher voltage than the limit will damage the driver IC.
在 OLED 驱动电压内来操作模块是必要的。超过限定电压会损坏集成电路。
3. The brightness will be lower at lower temperature than the normal temperature and will be higher at higher temperature. However those phenomena do not mean malfunction or out of order with OLED's, which will come back in the normal temperature.
OLED 亮度在低温时比常温要暗, 高温时, 会比常温要高。然而,这并不是指 OLED 示屏工作异常, 显示屏在恢复常温时, 效果会恢复正常。
4. If the display area is pushed hard, the display will cause pixel short, it will become the display defect.
如果在运行过程中显示区受到挤压,将可能引起像素短路, 引起显示缺陷。
5. A slight dew depositing on terminals is a cause for electro-chemical reaction resulting in terminal open circuit. Usage under the maximum operating temperature, 50%RH or less is required.
接线端冷凝会引起电化学反应而断路。因此必须在最大的操作温度之内, 湿度小于 50% 的条件下使用 OLED 模块。
6. Input logic voltage before apply analog high voltage such as OLED driving voltage when power on. Remove analog high voltage before logic voltage when power off the module. Input each signal after the positive/negative voltage becomes stable.
开机时, 先接通逻辑电压, 再接通模拟高压, 比如 OLED 驱动电压。关机时, 先断开模拟高压, 再关逻辑电压。正负电源都稳定后再送控制信号。
7. Please keep the temperature within the specified range for use and storage. Polarization degradation, bubble generation or polarizer peel-off may occur with high temperature and high humidity.
模块在操作和存储规格范围内使用。高温高湿可能会引起偏振退化, 起泡, 偏光片脱落等问题。

◆ **Safety 安全**

1. It is recommended to crush damaged or unnecessary OLED into pieces.
建议将损坏的 OLED 显示屏压成碎片。
2. If any solid or powder leaks out of a damaged glass cell and comes in contact with the hands, wash off thoroughly with soap and water.
如果任何固体或粉末从玻璃种泄漏出且与手接触,要用肥皂和水彻底清洗。



