

Specification for Approval

Customer Name InterElcom

Product ID _____

Product Model IE-5RO4-Y-T-IC

Product Specifications 5mm Bi-Color LED Red/Orange Blinking

Date _____

Customer acknowledges that

Approved	Audit	Confirm	Business	Engineering	Make

Customer acknowledges that

Qualified

Failure

Customer feedback

Product Model

Dimensions: Unit: mm [] [inch]

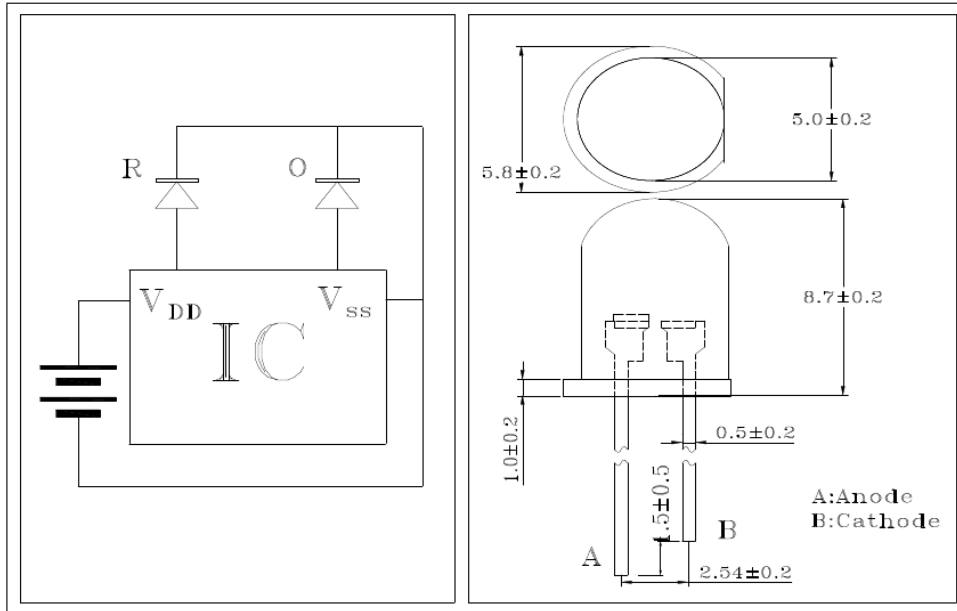

Notes:

1. mm
All dimension units are millimeters.
2. ±0.05
All dimension tolerance is ±0.05mm unless otherwise noted.
3. 1.5mm
An epoxy meniscus may extend about 1.5mm down the leads
4. 30u" min 80 u" min
5. 0.12mm

LED Chip LED		Lens Color
Material	Emitting Color	
InGaN	Red/Orange	Water Clear

Product Model:

Absolute maximum rating Ta 25

Peak current duty 0.1,1KHz 100 mA
Operating/Storage temperature range -30 ~ +85
Derating linear from 25 0.4 mA/
Lead soldering temperature range 260 for 3 second
Colloid Color:White Clear
Life Test:20,000 50,000hours

Electro-optical characteristics TA 25

RED COLOR

Parameter	Symbol	Min	Typ.	Max	Unit	Test Condition
Forward voltage	V _F		2.00	2.2	V	IF 20 mA
Luminous intensity	I _V		80	100	mcd	IF 20 mA
Peak emission wavelength	p		620	625	nm	
Half intensity angle			45		deg	

ORANGE COLOR

Parameter	Symbol	Min	Typ.	Max	Unit	Test Condition
Forward voltage	V _F		2.0	2.2	V	IF 20 mA
Luminous intensity	I _V		90	110	mcd	IF 20 mA
Peak emission wavelength	p		600	605	nm	
Half intensity angle			45		deg	

Direct Current Characteristics

Parameter	Symbol	Min	Typ.	Max	Unit	Remarks
Operating voltage	V _{DD}	2.0	4.5	5.5	V	
Driver Current	I _{ol}		50		mA	@V _{DS} =1.2V
Power Consumption	P _o		225		mW	V _{DD} =4.5V
Flash Frequency	F _{tet}		1.5		Hz	External 30%

Product Model:

Reliability Test Items/

No.	Item	Condition	Time/Cycle	Number of Damaged /
1.	Soldering Heat Test	260±5 °C	10 sec	0/60
2	Thermal Shock	0 °C (15sec) ~ 100 oC(15sec)	20 cycle	0/60
3	High Temp. Storage	100 °C	1000Hrs	0/60
4	Low Temp. Storage	-40 °C	1000Hrs	0/60
5	Temperature Cycle Test	-40 °C ~ 80 °C	100 Cycles, 200 Hrs	0/60
6	High Temp. High Humidity Test	60 °C, 90 % RH	1000 Hrs	0/60
7	Operation Life Test 1	Room Temp., 20mA	1000 Hrs	0/60
8	Operation Life Test 2	Room Temp., 30mA	500 Hrs	0/60
9	High Temp. Operation Life Test	85 °C , 20mA	1000 Hrs	0/60
10	Low Temp. Operation Life Test	-30 °C , 20mA	1000 Hrs	0/60

Judgment Criteria/

Item	Symbol	Test Conditions	Judgment Criteria
Forward Voltage	Vf	I _F = 20 mA	% < 10 %
Leakage Current	I _r	V _r = 5V	< 10 uA
Luminous Intensity	I _v	I _F = 20 mA	% <30 %
Luminous Flux	lm	I _F = 20 mA	% <30 %