

specification for approval

(Customer) :

(customer part no) IE-10WW-SB-D-CFT

(customer part no) :

(Product name) :

(Product Model) : IE-10WW-SB-D-CF

Customer Signatuers	Inspection	Production

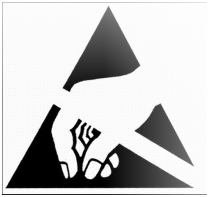

ATTENTION 注意
 OBSERVE PRECAUTIONS
 FOR HANDLING
 ELECTROSTATIC
 DISCHARGE
 SENSITIVE
 DEVICES

Features

Φ 10 LAMP LED Φ 10 LED Long life-solid
 state reliability
 Low power consumption
 IDEAL FOR BACKLIGHT AND INDICATOR.

Package Dimensions

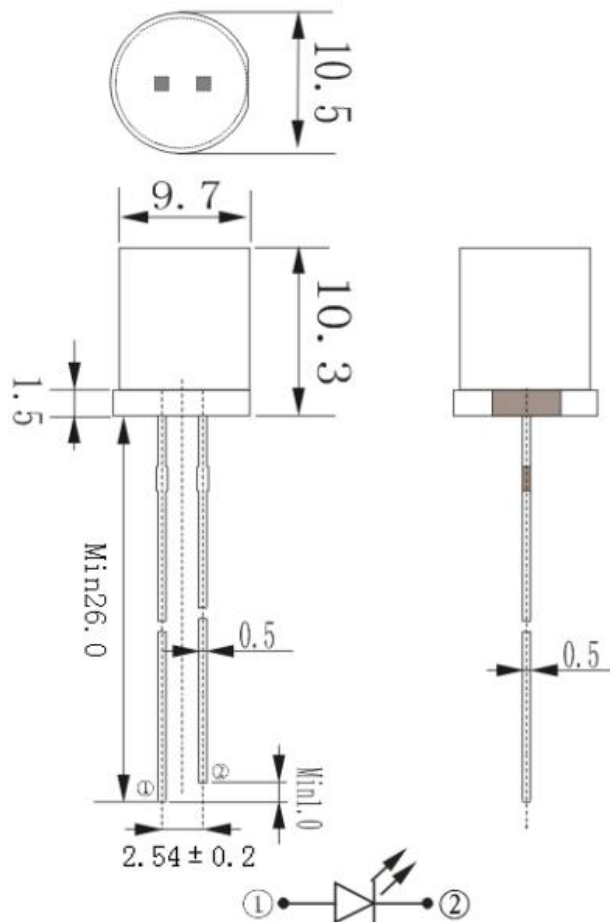

Tolerance Grade	Dimension Tolerance (UNIT:mm)			
	0.5~3	3~6	6~30	30~120
	± 0.1	± 0.2	± 0.3	± 0.5
CHIP Emitting Color	Warm White	Lens Color	White Diffused	

■ Absolute Maximum Rating

Item	Symbol	Value	Unit
Forward Current	IF	30	mA
Peak Forward Current*	IFP	100	mA
Reverse Voltage	VR	6	V
Power Dissipation	PD	80	mW
Electrostatic discharge(HBM)	ESD	1000	V
Operation Temperature	Topr	-25~ +100	°C
Storage Temperature	Tstg	-40~ +100	°C
Lead Soldering Temperatur	Tsol	Max. 265°C for 5sec Max.	--

*IFP Conditions :F=1KHZ, Duty cycle 1/10

*Tsol Conditions : 1.5mm from the base of the epoxy bulb

■ Typical Optical/ Electrical Characteristics Ta=25°C

Item	Symbol	Condition	Min.	Typ.	Max.	Unit
Luminous Intensity	Iv	IF=20mA	570	1000	1900	mcd
Forward Voltage	VF		2.8	3.0	3.6	V
Viewing Angle	2θ 1/2		--	180	--	deg
Color Coordinate	X		0.43	--	0.49	--
	Y		0.40	--	0.44	--
Reverse Current	IR	Vr=5V	--	--	10	uA

Notes:

Tolerance : VF \pm 0.1V, λ d \pm 2 nm, IV(ϕ V) \pm 15%

■ Reliability Performance

Test Items And Result

Test Classification	Test Item	Test Conditions	Test Duratio	Sample Size	AC/RE
Life Test	Room Temperature DC Operating Life Test	Ta=25°C \pm 5°C, If=20mA	1000hrs	22 pcs	0/1
Environment Test	Thermal Shock Test	100°C \pm 5°C 5min ↑ ↓ -40°C \pm 5°C 5min.	100cycles	22 pcs	0/1
	Temperature Cycle Test	100°C \pm 5°C 30min ↑ ↓ 5min -40°C \pm 5°C 30min.	100cycles	22 pcs	0/1
	High Temperature & High Humidity Test	85°C \pm 5°C/85% RH If=5mA	1000hrs	22 pcs	0/1
	High Temperature Storage	Ta=100°C \pm 5°C	1000hrs	22 pcs	0/1
	Low Temperature Storage	Ta=-40°C \pm 5°C	1000hrs	22 pcs	0/1
Mechanical Test	Resistance to Soldering Heat	Temp=260°Cmax T=5sec max	1times	22 pcs	0/1
	Lead Integrity	Load 2.5N(0.25kgf) 0° ~ 90° ~0°	3times	22 pcs	0/1
Salt Spray Test	Salt Spray Experiment	Ta=35°C Spray quantity(ml/80cm ² /H)1.0~2.0ml Concentration(NaCl)5%	0hrs	22 pcs	0/1

RELATIVE INTENSITY vs WAVELENGTH

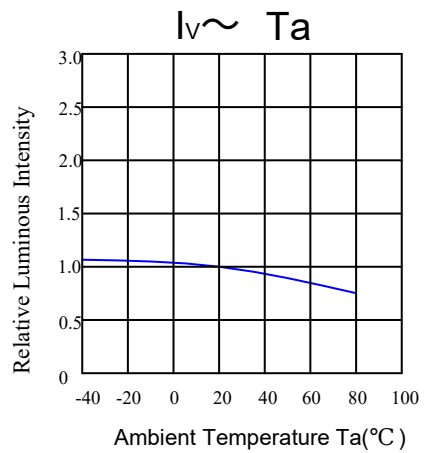
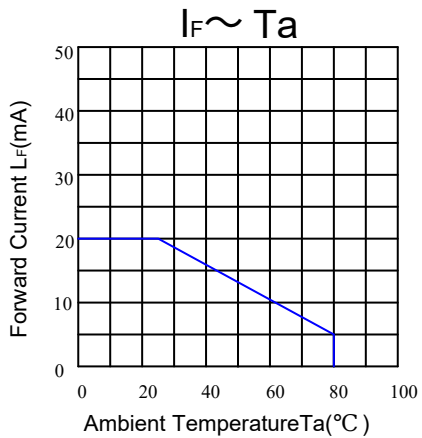
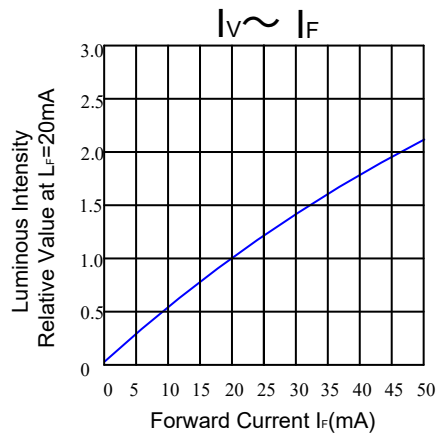
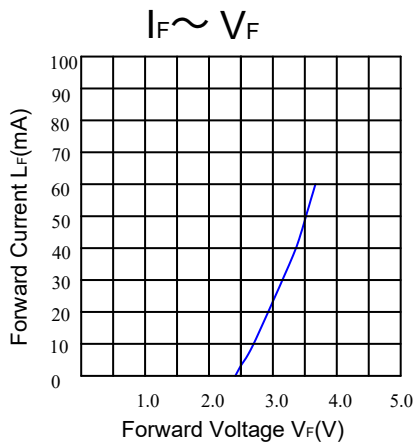
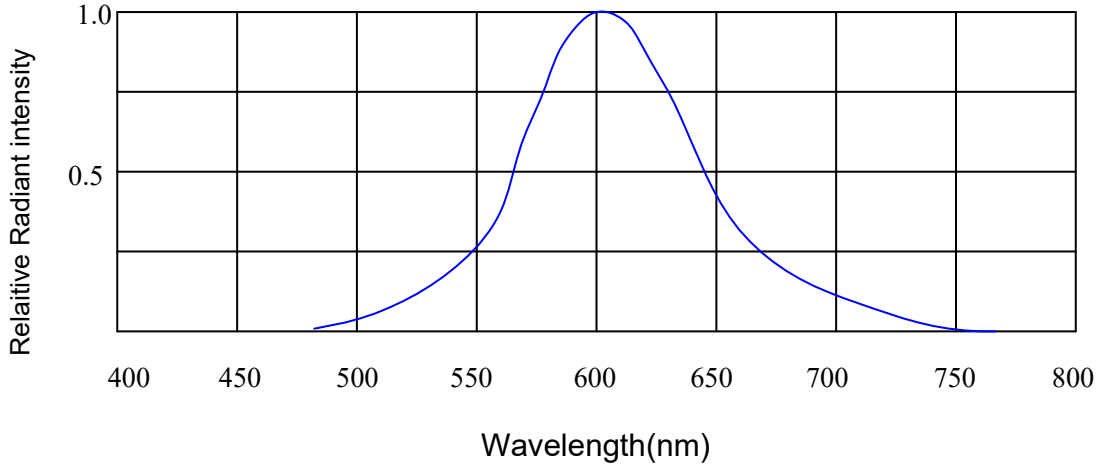

Precautions

1.Soldering:

DIP soldering (Wave Soldering):

Preheating:120°C~150°C,within 120~180 sec.

Operation heating:260°C±5°C within 5 sec.265°C(Max)

Gradual Cooling (Avoid quenching).

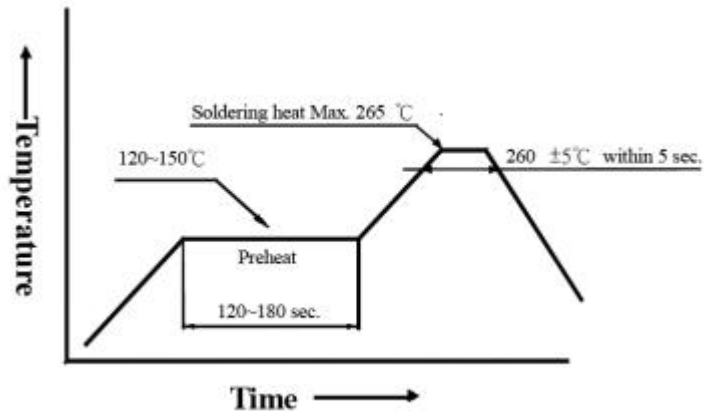

Be careful because damages always caused during soldering. Please note that stress to the leads and expose bulb should be avoided during soldering particularly when heated. When soldering, leave certain distance from soldering joint to base, the distance is determined by different soldering techniques.

Manual welding LED chips, can not weld LED two pins at the same time.

This LED products can not be reflow soldering

2.Storage

Under the storage conditions of 30°C or less and humidity less than 60%RH, the LEDs can be storage for 3months.

Storage in a sealed container with moisture absorbent material can prolong the storage time to a certain extent bad storage conditions may cause the lead frames to corrode or degradation of LED characteristics. It is recommended that the LEDs be used as soon as possible.

3. Static electricity (静电)

Static electricity of surge voltage damages the LED .Damaged LED will show some unusual chrematistics such as the forward voltage becomes lower or the LED do not light at the low current even not light. All devices equipment and machinery must be properly grounded. At the same time, it is recommended that wrist Bands or anti-electrostatic gloves anti-electrostatic containers be used when dealing with the LED.

When the working environment of electrostatic value more than 1000 v, it is recommended to use zener diode LED lamp bead.

4. Design Consideration

When designing a circuit, the current through each LED must not exceed the absolute maximum rating specified for each LED .In the meanwhile , resistors for protection should be applied otherwise slight voltage shift will cause big current change, bum out may happen.

Thermal Design is paramount important in because heat generation may result in the Characteristics decline, such as brightness decreased, Color changed and so on. Please consider the heat generation of the LED when making the system design.

5.Lead Forming

Any lead forming must be done before soldering, not during or after soldering. When forming leads ,the leads should bent at a point at least 3mm from the base of the expose bulb. Bending at the same point twice or even more should be avoided.

Please use proper tools to hold and bent the leads, do not use the base of the lead frame as a fulcrum during lead forming .Bending s tress to the base of the lead frame may cause character is tics change on LED or even break it.

Just for the same reason, when mounting the LED on to printed circuit board, the holes on the circuit board should be exactly aligned with the leads of the LED.

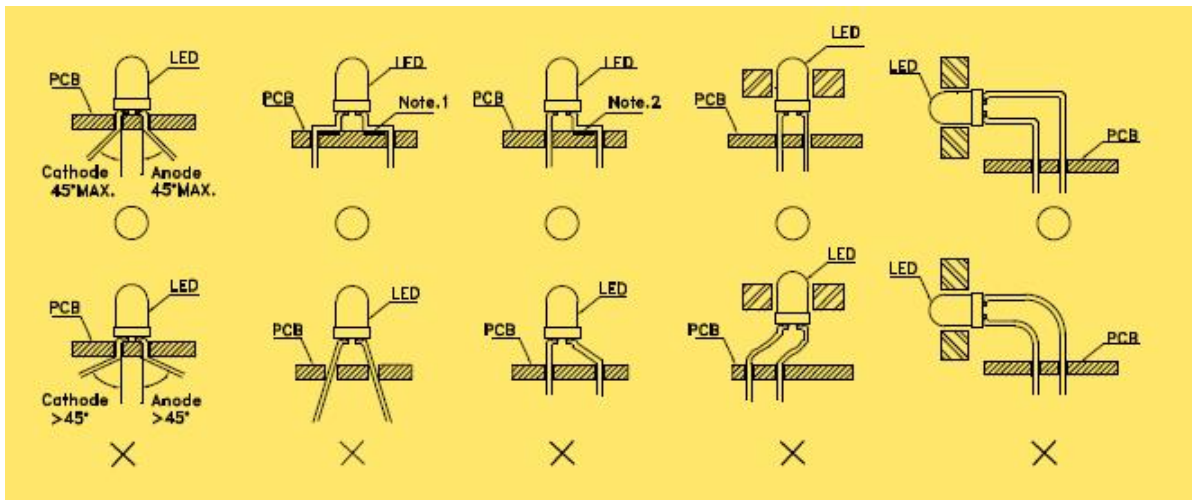

LED flat or make AI, suggest using $\Phi 4$, $\Phi 5$ LED chips, to avoid LED chips cracking caused by outside force, and please note dynamics for AI.

6.cleaning

Recommending using ethanol as solvent cleaning, do not use corrosive chemical liquid to clean LED, thus may damage epoxy resin of LED surface , even cause colloid cracks, meanwhile will produce corrosion rust on the LED tube feet.