

Specification for approval

CUSTOMER NAME: _____

DIRECTOR: _____ TITLE: _____

CUSTOMER PART NO.: _____

PART NUMBER: IE-2005PG-ST-C REVISION: 2.0

:
ISSUE DATE: 2014-11-27 RETURN DATE: / /

We are please in sending you herewith our specification and drawings for your approval.
Please return to us one copy "For Approval" with your approved signatures.

CUSTOMER'S PROPOSAL

- AGREE
- DISAGREE

REASON _____

CUSTOMER SIGNATURE: _____



Features

- _2.0mmX0.5mm SMT LED, 0.96 mm THICKNESS.
- _LOW POWER CONSUMPTION.
- _WIDE VIEWING ANGLE.
- _IDEAL FOR BACKLIGHT AND INDICATOR.
- _VARIOUS COLORS AND LENS TYPES AVAILABLE.
- _PACKAGE: 3000PCS / REEL.
- _RoHS COMPLIANT.

Package Dimensions

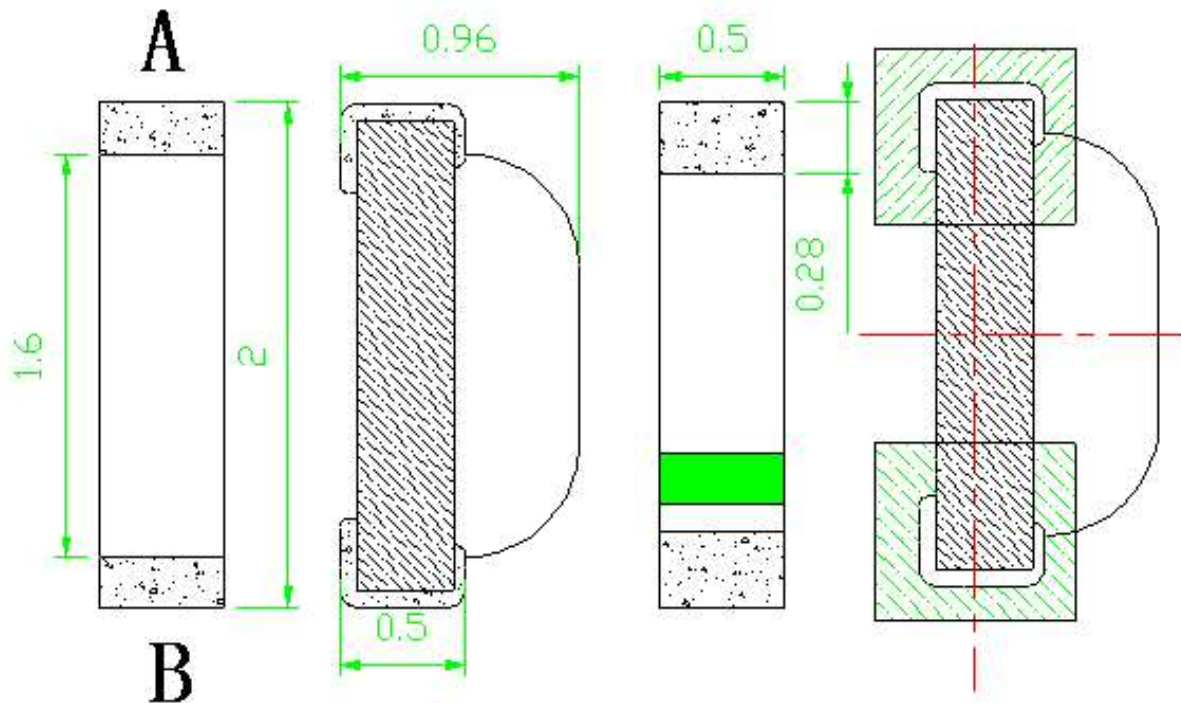

Description

The GREEN source color devices are made with GaN on Sapphire Light Emitting Diode.

Static electricity and surge damage the LEDs.

It is recommended to use a wrist band or anti-electrostatic glove when handling the LEDs.

All devices, equipment and machinery must be electrically grounded.

Notes:

1. All dimensions are in millimeters (inches).
2. Tolerance is ± 0.1 (0.004") unless otherwise noted.
3. Specifications are subject to change without notice.

Selection Guide

Part No.	Dice	Lens Type	Iv (mcd) @ 20mA		Viewing Angle
			Min.	Typ.	2 θ 1/2
IE-2005PG-ST-C	GREEN (GaN)	WATER CLEAR	400	700	120

Note:

1. θ1/2 is the angle from optical centerline where the luminous intensity is 1/2 the optical centerline value.

Electrical / Optical Characteristics at T_A=25°C

Symbol	Parameter	Device	Typ.	Max.	Units	Test Conditions
λ _{peak}	Peak Wavelength	GREEN	518	526	nm	IF=20mA
λ _D	Dominant Wavelength	GREEN			nm	IF=20mA
Δλ _{1/2}	Spectral Line Half-width	GREEN	25		nm	IF=20mA
C	Capacitance	GREEN	105		pF	VF=0V;f=1MHz
VF	Forward Voltage	GREEN	3.0	3.4	V	IF=20mA
IR	Reverse Current	GREEN		2	uA	VR = 7V

Remarks:

If special sorting is required (e.g. binning based on forward voltage, luminous intensity, or wavelength), the typical accuracy of the sorting process is as follows:

1. Wavelength: +/-1nm
2. Luminous Intensity: +/-15%
3. Forward Voltage: +/-0.1V

Note: Accuracy may depend on the sorting parameters

Absolute Maximum Ratings at T_A=25°C

Parameter	GREEN	Units
Power dissipation	135	mW
DC Forward Current	30	mA
Peak Forward Current [1]	140	mA
Reverse Voltage	5	V
Operating/Storage Temperature	-40°C To +85°C	

Note:

1. 1/10 Duty Cycle, 0.1ms Pulse Width.

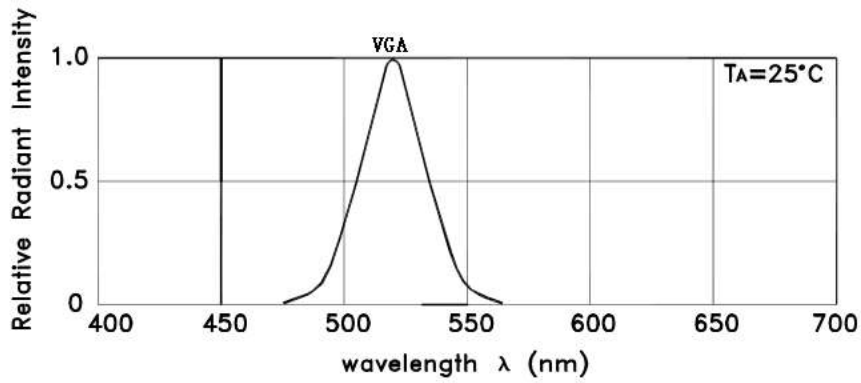

RELATIVE INTENSITY Vs. WAVELENGTH

GREEN

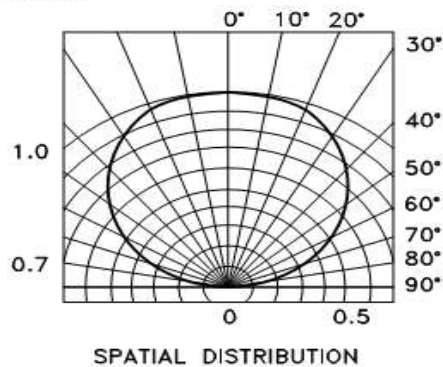
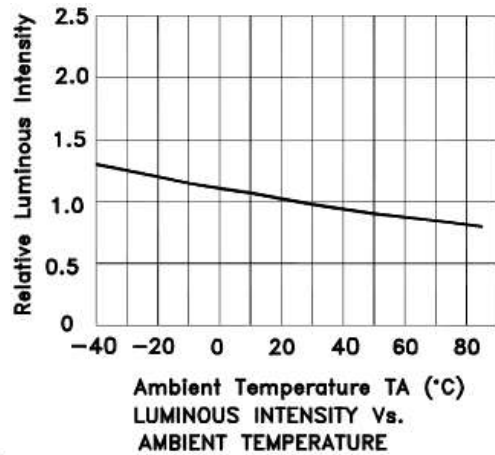
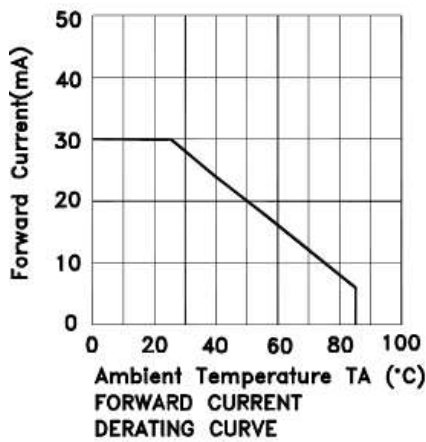
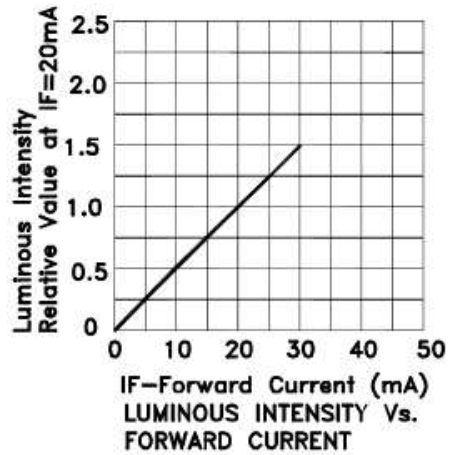
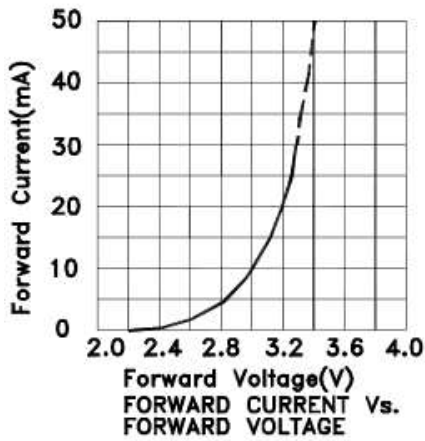

RELIABILITY

Test Items and Results

序号	试验项目	参考标准	试验条件	持续时间	取样数	接收水准 (不合格数量/抽样总数)
1	温度循环	JEITA ED-4701	-40°C ~25°C ~100°C ~ 25°C 30 分钟 5 分钟 30 分钟 5 分钟	循环 100 回合	50	0/50
2	冷热冲击	MIL-STD-202G	-40°C ~100°C 15 分钟 15 分钟	循环 500 回合	50	0/50
3	高温储存	JEITA ED-4701 200 201	T _a =100°C	1000 小时	50	0/50
4	低温储存	JEITA ED-4701 200 201	T _a =-40°C	1000 小时	50	0/50
5	常温寿命 试验		T _a =25±5°C I _F =20mA	1000 小时	50	0/50
6	高温高湿 寿命试验		T _a =60°C RH=85% I _F =20mA	1000 小时	50	0/50
7	可焊性 (回流焊)	JEITA ED-4701 300 303	T _{sol} =235°C±5°C,5 秒 使用助焊剂	焊接一 次, 5 秒	10	0/10
8	耐焊性 (回流焊)	JEITA ED-4701 300 301	T _{sol} =260°C,10 秒 预处理: 35°C 95%RH 96 小时	焊接二 次, 每次 10 秒	10	0/10
备注	以上试验项目如与客户试验要求存在差异的或者特殊客户特殊要求的可根据实际情况按照客户的要 求进行试作,客户未要求的按我司试验标准试作,不同产品使用不同电流进行测试					

5. Cautions

(1) Soldering Conditions

Number of reflow process shall be less than 2 times and cooling process to normal temperature is required between first and Second soldering process.

(Recommended soldering conditions)

回流焊接 Reflow Soldering		手工焊接	
预热温度 Pre-heat	有铅 Lead Solder	无铅 Lead-free Solder	温度 Temperature
预热时间 Pre-heat time	140 ~ 160° C 120 sec. Max.	180 ~ 200° C 120 sec. Max.	焊接时间 Soldering time
峰值温度 Peak temperature	230° C Max. 10 sec. Max.	240° C Max. 10 sec. Max.	350° C Max. 3 sec. Max. (one time only)
焊接时间 Soldering time	参考下图	参考下图	
条件 Condition			

(Lead Solder)

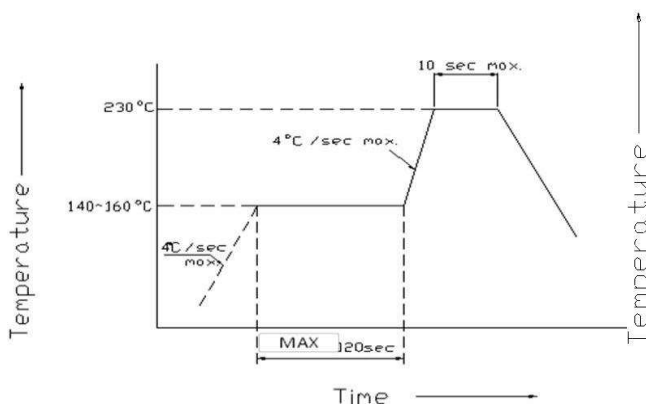

(Lead-Free Solder)

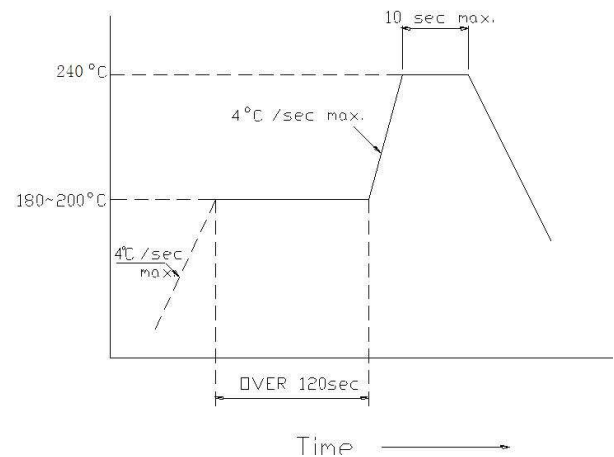

Recommended Soldering Pattern

(Units : mm)

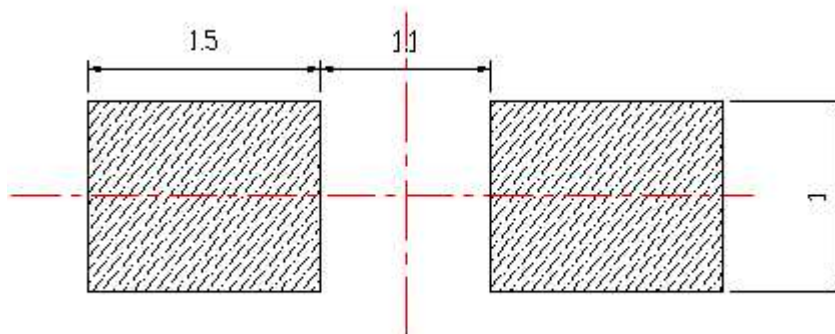

(2) Static Electricity

It is recommended that a wrist band or an anti-electrostatic glove be used when handling the LEDs.

All devices, equipment and machinery must be properly grounded.

2.0V Damaged LEDs will show some unusual characteristics such as the forward voltage becomes lower, or the LEDs do not light at the low current. Criteria : (VF > 2.0V at IF=0.5mA)

(3) Moisture Proof Package

It is recommended that moisture proof package be used .

(4)

Cautions:

4.1.

Please check if there is air leak before opening the package, if so, please return the goods back to take drying process for later using.

4.2

Products can be used within 15days after packaging, after that, they must be:

4.2.1

Soldered within 24 hrs

4.2.2

Used in the condition: 30°C within and 60%RH below

4.2.3

Stored in 30%RH for moisture below.

4.3.

Products cannot be used for and over 15days after being packaged unless opening the package and take drying our process in 85°C/6H.

4.4.

Products not be used for or over 60days after being packaged please return back to take drying out and packaging process for forward using.

4.5.

Products not be used after opening the package need to be dried out for 85°C/6H

PACKAGING

The LEDs are packed in cardboard boxes after taping.

包装方式:

TAPE

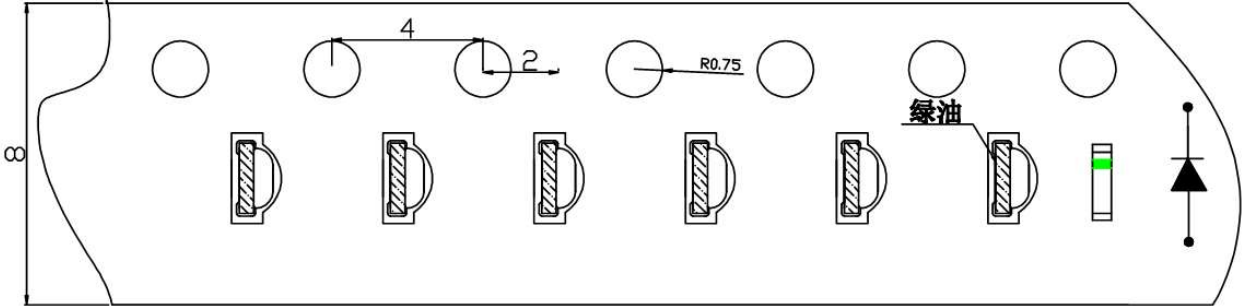

0802

Package: 4000PCS/reel

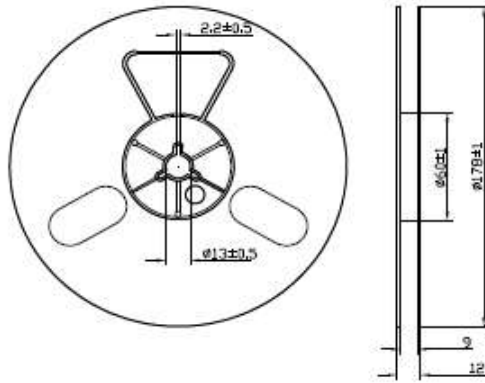

Moisture Resistant Packaging

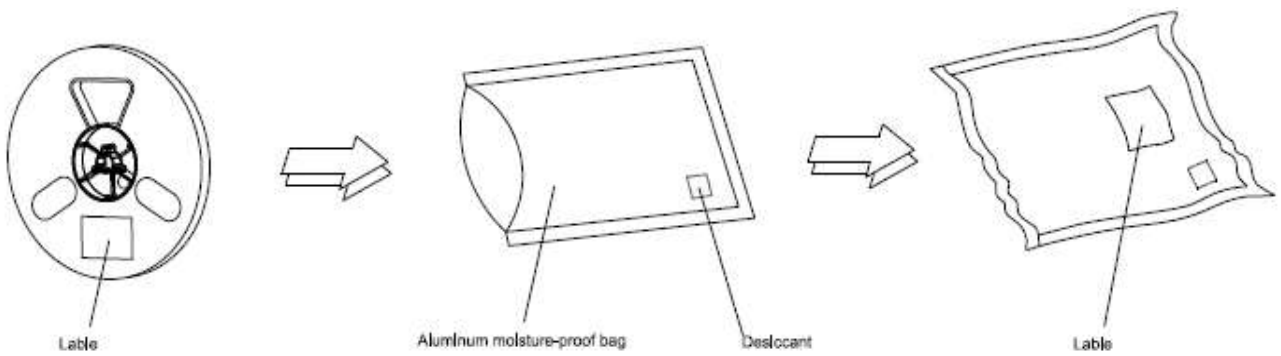

Note: The tolerances unless mentioned is ± 0.1 mm, Unit: mm