

SPECIFICATION

Product Model: IE-SN-1110CH05R24-R0-1

Table Of Contents

List	Description	Page No.
	Cover	1
	Revision Record	2
	Table Of Contents	3
1	Numbering System	4
2	General Information	4
3	External Dimensions	5
4	Interface Description	6
5	Absolute Maximum Ratings	6
6	Electrical Characteristics	6
7	Timing Characteristics	7
8	Backlight Characteristics	9
9	Optical Characteristics	9
10	Reliability Test Conditions And Methods	11
11	Inspection Standard	12
12	Handling Precautions	13, 14

1. Numbering System

TBD

2. General Information

ITEM	STANDARD VALUES	UNITS
LCD type	4.3" TFT	--
Dot arrangement	480(RGB)×272	dots
Color filter array	RGB vertical stripe	--
Display mode	TN / Transmission / Normally White	--
Viewing Direction	all o'clock	--
Driver IC	ST7283	--
Module size	105.5(W)×67.2(H)×4.0(T)	mm
Active area	95.04(W)×53.856(H)	mm
Dot pitch	0.198 (W)×0.198 (H)	mm
Interface	18-bit Parallel RGB Interface	--
Operating temperature	-20 ~ +70	°C
Storage temperature	-30 ~ +80	°C
Back Light	10 White LED	--
Weight	TBD	g

4. Interface Description

Pin	Symbol	Description.
1	LEDK	LED backlight (Cathode).
2	LEDA	LED backlight (Anode).
3	GND	Ground.
4	VCC	Power supply.
5~12	R0~R7	Red Data.
13~20	G0~G7	Green Data.
21~28	B0~B7	Blue Data.
29	GND	Ground.
30	DCLK	Clock signal.
31	DISP	Display control/standby mode selection.
32	HSYNC	Horizontal sync signal.
33	VHYN	Vertical sync signal.
34	DE	Data input enable.
35	NC	No connect
36	GND	Ground.
37	XR	RTP right
38	YD	RTP down
39	XL	RTP left
40	YU	RTP up

5. Absolute Maximum Ratings

Item	Symbol	Min.	Max.	Unit
Supply Voltage	Vcc	-0.3	4.6	V
Operating Temperature	TOP	-20	70	°C
Storage Temperature	TST	-30	80	°C
Storage Humidity	HD	20	90	%RH

6. DC Characteristics

Item	Symbol	Min.	Typ.	Max.	Unit	Remark
Supply Voltage	VDD	3.0	3.3	3.6	V	-
Input High Voltage	V _{IH}	0.7VDD	-	VDD	V	Digital input pins
Input Low Voltage	V _{IL}	GND	-	0.3VDD	V	Digital input pins
Output High Voltage	V _{OH}	VDD-0.4	-	VDD	V	Digital output pins
Output Low Voltage	V _{OL}	GND	-	VDD+0.4	V	Digital output pins
Current Consumption	I _{vdd}	---	13	16	mA	With internal voltage generation VDD=3.3V T _{amb} =25°C -

7. Timing Characteristics

7.1 Power ON/OFF Sequence

Power ON Sequence

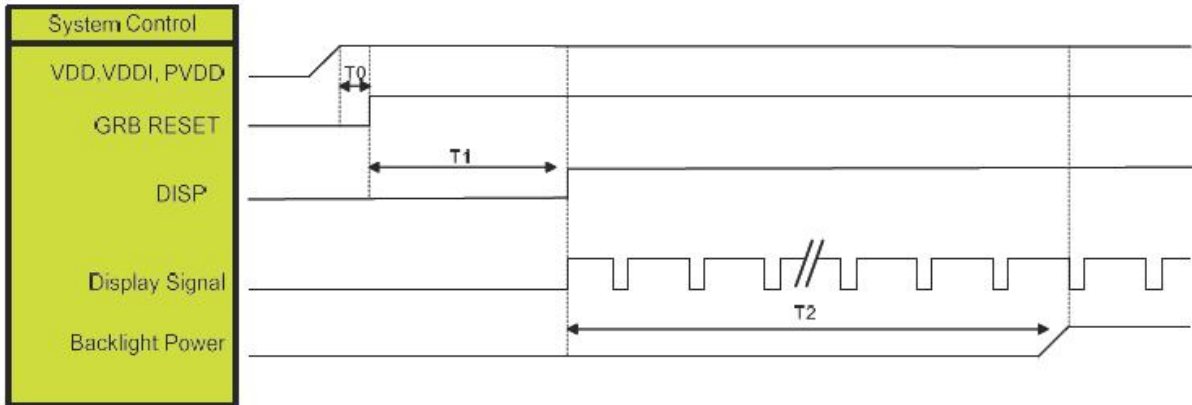

Power OFF Sequence

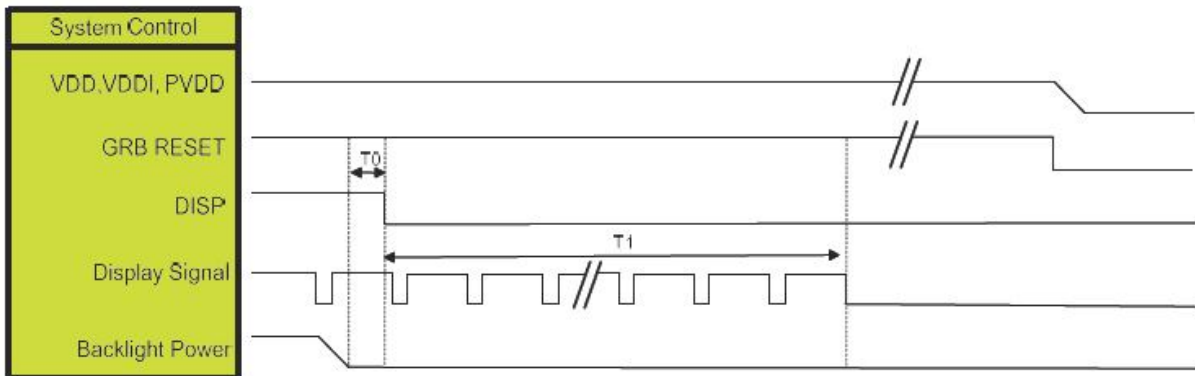

7.2 Data Input Format

7.2.1 Parallel RGB Mode Data format

SYNC mode

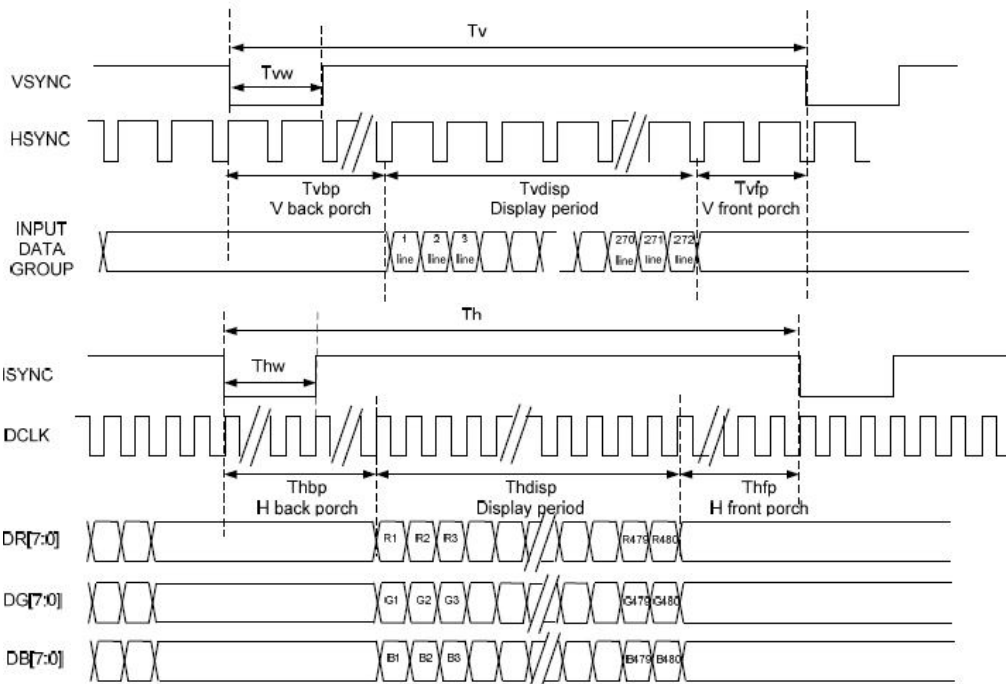

SYNC-DE mode

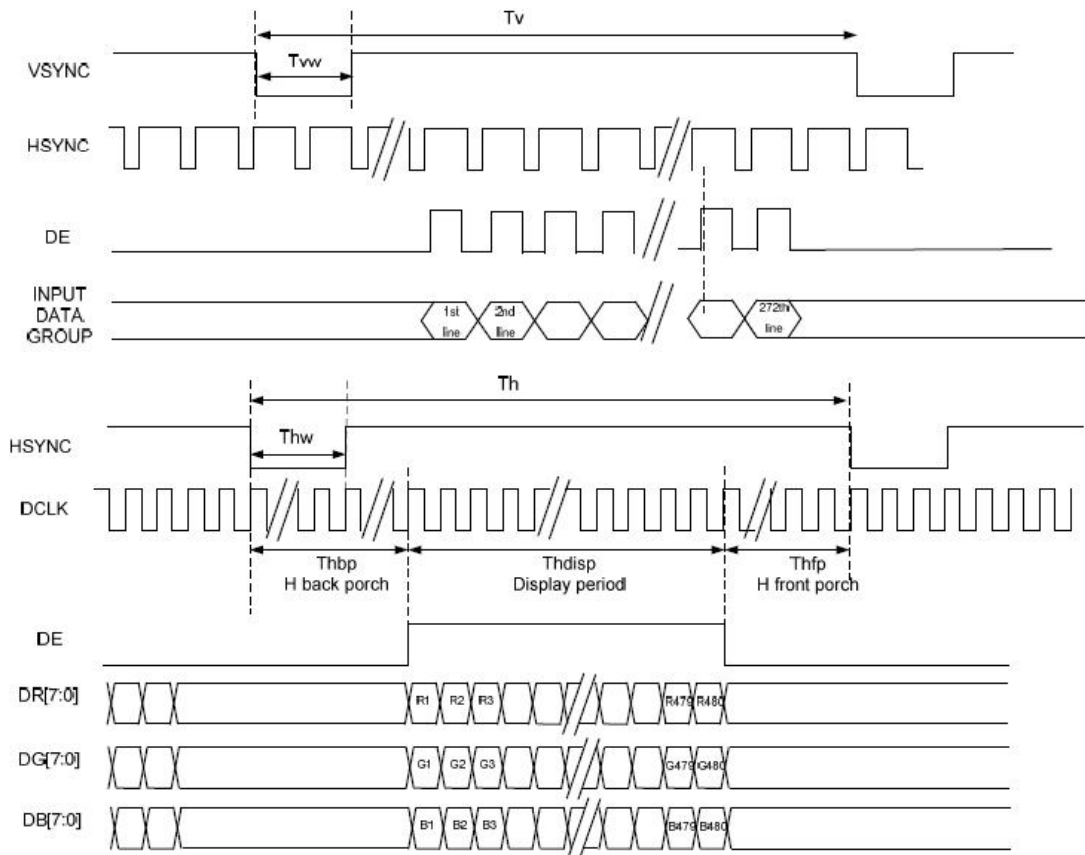

7.2.2 Parallel RGB input timing table

480RGB X 272 Resolution Timing Table							
Item	Symbol	Min.	Typ.	Max.	Unit	Remark	
DCLK Frequency	Fclk	8	9	12	MHz		
DCLK Period	Tclk	83	111	125	ns		
HSYNC	Period Time	T_h	485	531	598	DCLK	
	Display Period	T_{hdisp}		480		DCLK	
	Back Porch	T_{hbp}	3	43	43	DCLK	By H_BLANKING setting
	Front Porch	T_{hfp}	2	8	75	DCLK	
	Pulse Width	T_{hw}	2	4	43	DCLK	
VSYNC	Period Time	T_v	276	292	321	HSYNC	
	Display Period	T_{vdisp}		272		HSYNC	
	Back Porch	T_{vbp}	2	12	12	HSYNC	By V_BLANKING setting
	Front Porch	T_{vfp}	2	8	37	HSYNC	
	Pulse Width	T_{vw}	2	4	12	HSYNC	

Note: It is necessary to keep $T_{vbp} = 12$ and $T_{hbp} = 43$ in sync mode. DE mode is unnecessary to keep it.

NOTE: If there is an error, please refer to ST7283 datasheet.

8. Backlight Characteristics

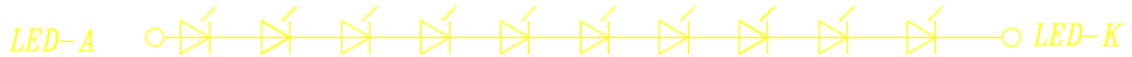

Item	Symbol	MIN	TYP	MAX	UNIT	Test Condition
Supply Voltage	Vf	28	31	32	V	If=20mA
Supply Current	If	--	20	--	mA	-
Luminous Intensity for LCM	-	450	500	--	Cd/m ²	If=20mA
Uniformity for LCM	-	80	-	-	%	If=20mA
Life Time	-	30000	-	-	Hr	If=20mA
Backlight Color	White					

9. Optical Characteristics

Parameter		Symbol	Condition	Min.	Typ.	Max.	Unit	Remark
Viewing Angle	Horizontal	θ3	CR>10	80	85		%	Note 1
		θ9		80	85		%	
	Vertical	θ12		80	85		%	
		θ6		80	85		%	
Contrast Ratio		CR	θ= 0°	800	1000			Note 2
Transmittance		T(%)	θ= 0°	5.2	5.8			Note 3
NTSC		%	θ= 0°		50%			C light
Reproduction Of color	Red	Rx	θ= 0°	0.593	0.608	0.623		Note 4 *Color filter Glass(with OC)
		Ry		0.308	0.323	0.338		
	Green	Gx		0.302	0.317	0.332		
		Gy		0.534	0.549	0.564		
	Blue	Bx		0.13	0.145	0.16		
		By		0.123	0.138	0.153		
White		Wx	θ= 0°	0.293	0.308	0.323		
		Wy		0.322	0.337	0.352		
Response Time		Tr+Tf	θ= 0°			40	ms	Note 5

Measuring Condition:

Dark room, 25±2°C, 15min. warm-up time.

Measuring Equipment

FPM520 of Westar Display technologies, INC., which utilized SR-3 for Chromaticity and BM-5A for other optical characteristics. Measuring spot size: 20 ~ 21 mm.

Note:

1. Viewing angle is the angle at which the contrast ratio is greater than 10. The viewing are determined for the horizontal or 3, 9 o'clock direction and the vertical or 6, 12 o'clock direction with respect to the optical axis which is normal to the LCD surface (see FIG.1). Viewing angle measuring is based on WV Pol attached.

2. Contrast measurements shall be made at viewing angle of θ= 0° and at the center of the LCD

surface. BLU with BEF, Luminance shall be measured with all pixels in the view field set first to white, then to the dark (black) state. (See FIG. 1) Luminance Contrast Ratio (CR) is defined mathematically.

$$CR = \frac{\text{Luminance when displaying a white raster}}{\text{Luminance when displaying a black raster}}$$

3. Transmittance is the value with SDI Up Polarizer and HC Down and HC/clear and backlight with BEF

4. The color chromaticity coordinates specified in Table1 shall be calculated from The spectral data measured with all pixels first in red, green, blue and white.

Measurements shall be made at the center of the C/F.

Measurement condition is C - light source & Halogen Lamp

5. The electro-optical response time measurements shall be made as FIG.2 by switching the "data" input signal ON and OFF.

The times needed for the luminance to change from 10% to 90% is Tf, and 90% to 10% is Tr.

Figure 1. Measurement Set Up

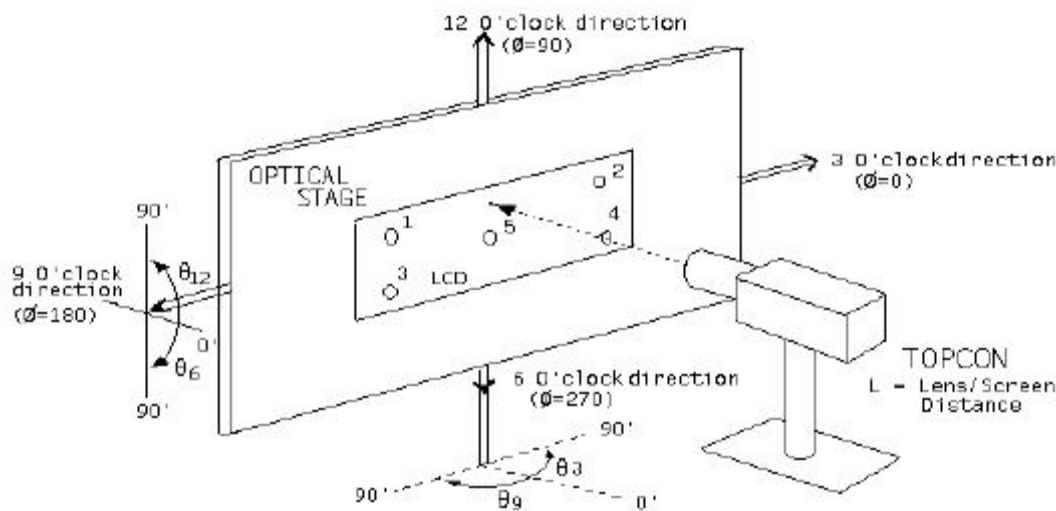
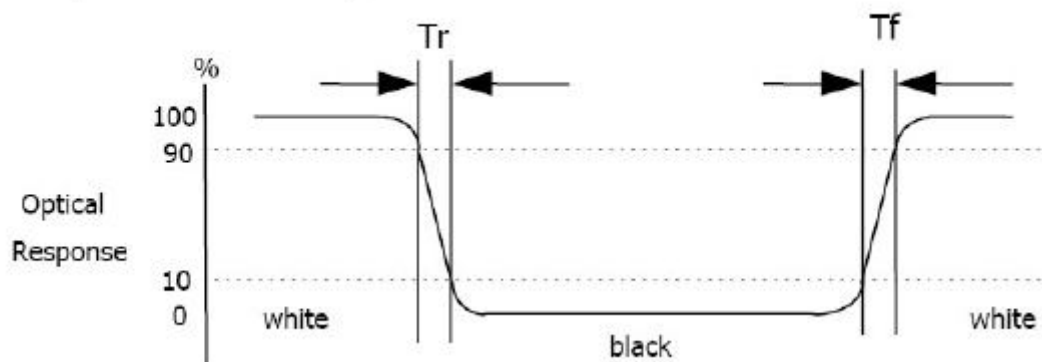

Figure 2. Response Time Testing



10. Reliability Test Conditions And Methods

NO.	TEST ITEMS	TEST CONDITION	INSPECTION AFTER TEST
①	High Temperature Storage	80°C±2°C×200Hours	Inspection after 2~4hours storage at room temperature,the samples should be free from defects: 1,Air bubble in the LCD. 2,Sealleak. 3,Non-display. 4,Missing segments. 5,Glass crack. 6,Current IDD is twice higher than initial value. 7,The surface shall be free from damage. 8,The electric charateristic requirements shall be satisfied.
②	Low Temperature Storage	-30°C±2°C×200Hours	
③	High Temperature Operating	70°C±2°C×120Hours	
④	Low Temperature Operating	-20°C±2°C×120Hours	
⑤	Temperature Cycle(Storage)	-20°C ↔ 25°C ↔ 70°C (30min) ← (5min) → (30min) 1cycle Total 10cycle	
⑥	Damp Proof Test (Storage)	50°C±5°C×90%RH×120Hours	
⑦	Vibration Test	Frequency:10Hz~55Hz~10Hz Amplitude:1.5M X,Y,Z direction for total 3hours (Packing Condition)	
⑧	Drooping Test	Drop to the ground from 1M height one time every side of carton. (Packing Condition)	
⑨	ESD Test	Voltage:±8KV,R:330Ω,C:150PF,Air Mode,10times	

REMARK:

- 1,The Test samples should be applied to only one test item.
- 2,Sample side for each test item is 5~10pcs.
- 3,For Damp Proof Test,Pure water(Resistance > 10MΩ)should be used.
- 4,In case of malfunction defect caused by ESD damage,if it would be recovered to normal state after resetting,it would be judge as a good part.
- 5,EL evaluation should be excepted from reliability test with humidity and temperature:Some defects such as black spot/blemish can happen by natural chemical reaction with humidity and Fluorescence EL has.
- 6,Failure Judgment Criterion:Basic Specification Electrical Characteristic,Mechanical Characteristic,Optical Characteristic.

11. Inspection Standard

This standard apply to TFT module specification.

1. Inspection condition:

Under daylight lamp 20~40W, product distance inspector'eye 30cm.incline degree 30° 。

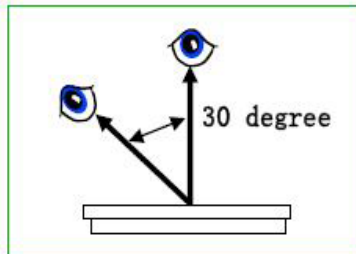

2. Inspection standard

NO.	Item	Inspection standard	Rate															
2.1	Dot	<p>Case of Dot defect is below</p> <p>① Bright Dot (whit spot) : "0"</p> <p>② Dark Dot (black spot) : "0" (In case of Dark Dot on Main TFT LCD)</p> <p>- NG if there's full Dot defect.</p> <p>- Damaged less than the size of sub-pixel is not counted as defect</p> <p>- Dots darker than the size of sub-pixel are not defined as bright dot defect</p> <table border="1"> <thead> <tr> <th>area size (mm)</th> <th>Acceptable number</th> </tr> </thead> <tbody> <tr> <td>$\Phi \leq 0.10$</td> <td>ignore</td> </tr> <tr> <td>$0.10 < \Phi \leq 0.15$</td> <td>3</td> </tr> <tr> <td>$0.15 < \Phi \leq 0.20$</td> <td>2</td> </tr> <tr> <td>$0.25 < \Phi \leq 0.25$</td> <td>1</td> </tr> <tr> <td>$0.25 < \Phi$</td> <td>0</td> </tr> </tbody> </table>	area size (mm)	Acceptable number	$\Phi \leq 0.10$	ignore	$0.10 < \Phi \leq 0.15$	3	$0.15 < \Phi \leq 0.20$	2	$0.25 < \Phi \leq 0.25$	1	$0.25 < \Phi$	0	minor			
area size (mm)	Acceptable number																	
$\Phi \leq 0.10$	ignore																	
$0.10 < \Phi \leq 0.15$	3																	
$0.15 < \Phi \leq 0.20$	2																	
$0.25 < \Phi \leq 0.25$	1																	
$0.25 < \Phi$	0																	
2.2	line	<table border="1"> <thead> <tr> <th colspan="2">Size (mm)</th> <th>Acceptable number</th> </tr> </thead> <tbody> <tr> <td>ignore</td> <td>$W \leq 0.03$</td> <td>ignore</td> </tr> <tr> <td>$L \leq 4.0$</td> <td>$0.03 < W \leq 0.04$</td> <td>2</td> </tr> <tr> <td>$L \leq 4.0$</td> <td>$0.04 < W \leq 0.05$</td> <td>1</td> </tr> <tr> <td></td> <td>$0.05 < W$</td> <td>Treat with dot non-conformance</td> </tr> </tbody> </table>	Size (mm)		Acceptable number	ignore	$W \leq 0.03$	ignore	$L \leq 4.0$	$0.03 < W \leq 0.04$	2	$L \leq 4.0$	$0.04 < W \leq 0.05$	1		$0.05 < W$	Treat with dot non-conformance	
Size (mm)		Acceptable number																
ignore	$W \leq 0.03$	ignore																
$L \leq 4.0$	$0.03 < W \leq 0.04$	2																
$L \leq 4.0$	$0.04 < W \leq 0.05$	1																
	$0.05 < W$	Treat with dot non-conformance																

12. Handling Precautions

12.1 Mounting method

The LCD panel of SS LCD module consists of two thin glass plates with polarizers which easily be damaged. And since the module is so constructed as to be fixed by utilizing fitting holes in the printed circuit board.

Extreme care should be needed when handling the LCD modules.

12.2 Caution of LCD handling and cleaning

When cleaning the display surface, Use soft cloth with solvent [recommended below] and wipe lightly

- Isopropyl alcohol
- Ethyl alcohol

Do not wipe the display surface with dry or hard materials that will damage the polarizer surface.

Do not use the following solvent:

- Water
- Aromatics

Do not wipe ITO pad area with the dry or hard materials that will damage the ITO patterns

Do not use the following solvent on the pad or prevent it from being contaminated:

- Soldering flux
- Chlorine (Cl), Sulfur (S)

If goods were sent without being silicon coated on the pad, ITO patterns could be damaged due to the corrosion as time goes on.

If ITO corrosion happens by miss-handling or using some materials such as Chlorine (Cl), Sulfur (S) from customer, Responsibility is on customer.

12.3 Caution against static charge

The LCD module uses C-MOS LSI drivers, so we recommend that you:

Connect any unused input terminal to V_{DD} or V_{SS}, do not input any signals before power is turned on, and ground your body, work/assembly areas, assembly equipment to protect against static electricity.

12.4 packing

- Module employs LCD elements and must be treated as such.
- Avoid intense shock and falls from a height.
- To prevent modules from degradation, do not operate or store them exposed directly to sunshine or high temperature/humidity

12.5 Caution for operation

- It is an indispensable condition to drive LCD's within the specified voltage limit since the higher voltage than the limit causes the shorter LCD life.
- An electrochemical reaction due to direct current causes LCD's undesirable deterioration, so that the use of direct current drive should be avoided.
- Response time will be extremely delayed at lower temperature than the operating temperature range and on the other hand at higher temperature LCD's show dark color in them. However those phenomena do not mean malfunction or out of order with LCD's, which will come back in the specified operation temperature.
- If the display area is pushed hard during operation, some font will be abnormally displayed but it resumes normal condition after turning off once.
- A slight dew depositing on terminals is a cause for electro-chemical reaction resulting in terminal open circuit.

Usage under the maximum operating temperature, 50%Rh or less is required.

12.6 storage

In the case of storing for a long period of time for instance, for years for the purpose or replacement use, the following ways are recommended.

- Storage in a polyethylene bag with the opening sealed so as not to enter fresh air outside in it .
And with no desiccant.
- Placing in a dark place where neither exposure to direct sunlight nor light's keeping the storage temperature range.
- Storing with no touch on polarizer surface by the anything else.
[It is recommended to store them as they have been contained in the inner container at the time of delivery from us

12.7 Safety

- It is recommendable to crash damaged or unnecessary LCD's into pieces and wash off liquid crystal by either of solvents such as acetone and ethanol, which should be burned up later.
- When any liquid leaked out of a damaged glass cell comes in contact with your hands, please wash it off well with soap and water