Preliminary Specification

Approval Specification

**SPECIFICATION
FOR
LCD MODULE**

Customer:

Product Model: IE-K-2218CH02MP-CB-1

Sample code:

Revision History

*Version	*Contents	*Date	Note
A0	Original	2023-10-19	
A1		2023-11-07	

1. Numbering System	4
2. Block Diagram	5
3. Technology Specifications	5
6. Interface Pin Assignment	6
7. Operation Specifications	7
10. Signal Timing Characteristics (see IC spec for details)	8
11. Optical specifications	10
12. Reliability Test Conditions And Methods	13
13. Handling Precautions	13
10. Precaution for use	14
11. Package Drawing	15
12. Outline Dimension	16
15. 条形码/二维码	17
16. HSF Requirements	17

2. Block Diagram

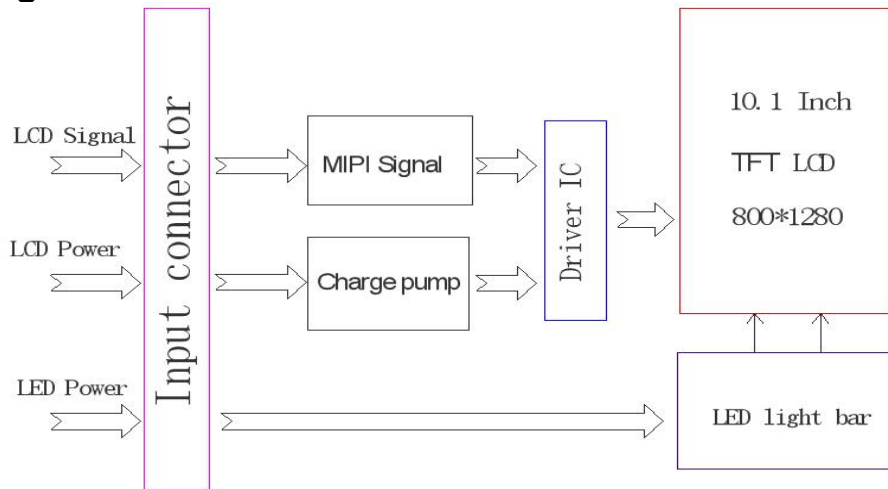

3. Technology Specifications

3.1 Features

This single-display module is suitable for use in MID products. The LCD adopts one backlight with High brightness 28-lamps white LED. Construction: 10.1" a-Si color TFT-LCD, White LED backlight, FPC.

3.2 General Specifications

No.	Item	Specification
1	LCD size (Inch)	10.1
2	Resolution	800(H)*1280(W) mm
3	Display mode	Normally Black
4	Pixel pitch	0.1692(H)X0.1692(V) mm
5	Active area	135.36(H)*216.58(V) mm
6	Module size(TPM)	159.70(H)*241.30(V)*4.70(T) mm
7	Pixel arrangement	RGB-stripe
8	Surface Treatment	HC
9	Interface	MIPI
10	Brightness (Tpy, cd/m ²)	280
11	TP Bonding Mode	框贴
12	Backlight power consumption (Tpy, W)	1710.000

4. Interface Pin Assignment

4.1 LCM Pin Assignment

Pin No	Symbol	Function
1	VLED	Anode for light bar
2	VLED	Anode for light bar
3	NC	NC
4	LED1	Cathode for light bar
5	LED2	Cathode for light bar
6	LED3	Cathode for light bar
7	ID	Connect 27K resistor to ground
8	TP_RST	Dedicated active low external reset pin 1.8V
9	TP_ATTN	Spare GPIO (may be used for ATTN)1.8V
10	TP_SDA	I2C data (SDA) or SPI data input (MOSI)1.8V
11	TP_SCL	I2C clock (SCL) or SPI clock (SCLK)1.8V
12	TP_GND	TP_Ground
13	NC	NC
14	VDDIN	2.8V input for TP
15	GND	Ground
16	RST	Device reset signal for LCM.Active low , HLH(1.8V)
17	LEDPWM	PWM control signal for LED driver (CABC). If no used, please keep it floating(1.8V)
18	NC	NC
19	NC	NC
20	BIST	(TEST for KD)NC
21	VDD	3.3V power input for LCM and Power ic
22	VDD	3.3V power input for LCM and Power ic
23	IOVCC	1.8V power input
24	GND	Ground
25	D0N	MIPI differential data0 input (Negative)
26	D0P	MIPI differential data0 input (Positive)
27	GND	Ground
28	D1N	MIPI differential data1 input (Negative)
29	D1P	MIPI differential data1 input (Positive)
30	GND	Ground
31	CLKN	MIPI differential clock input (Negative)
32	CLKP	MIPI differential clock input (Positive)
33	GND	Ground
34	D2N	MIPI differential data2 input (Negative)
35	D2P	MIPI differential data2 input (Positive)
36	GND	Ground
37	D3N	MIPI differential data3 input (Negative)
38	D3P	MIPI differential data3 input (Positive)
39	GND	Ground
40	NC	NC

5. Operation Specifications

5.1 Absolute Max. Rating

Item	Symbol	Values		Unit	Remark
		Min.	Max.		
Operation Temperature	TOP	-10	50	°C	
Storage Temperature	TST	-20	60	°C	
Backlight forward	ILED	-	25	mA	
Power Voltage	VDD	-0.3	5	V	
Input Signal Voltage	VI	-0.3	VDD	V	

Note 1: The absolute maximum rating values of this product are not allowed to be exceeded at any times. Should a module be used with any of the absolute maximum ratings exceeded, the characteristics of the module may not be recovered, or in an extreme case, the module may be permanently destroyed.

5.2 Typical Operation Conditions

Item	Symbol	Values			Unit	Remark
		Min.	Typ.	Max.		
Power Voltage	VDD	3.0	3.3	3.6	V	
Power Voltage	IOVCC	1.7	1.8	1.9	V	
Current Consumption	IVDD	-	65.0	-	mA	White
Current Consumption	IVDDIO	-	25.0	-	mA	White
Current Consumption	ILED	-	80.0	-	mA	White
Power Consumption	PLCD	-	0.3	-	W	White
Power Consumption	PLED	-	1.7	-	W	White

Note 1:

Frame Rate=60Hz ; Operating at 25°C at white pattern.

5.3 LED Back Light Specification

Item	Symbol	Condition	Min	Typ	Max	Unit
Forward Voltage	Vf	IF=80mA	18.9	-	23.8	V

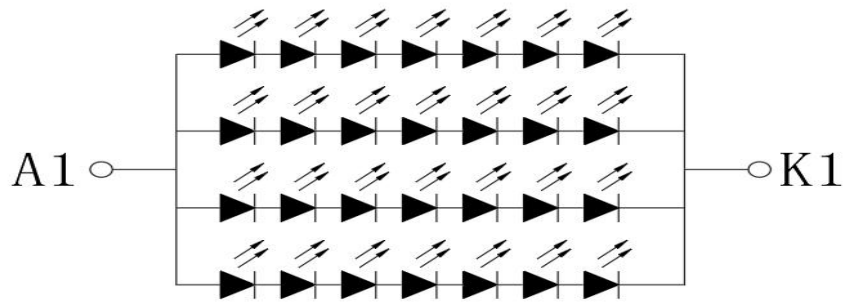

LED CIRCUIT DIAGRAM

7S*4P : 28LEDs

Vf=18.9V-23.8V (If=4*20=80mA)

6. Signal Timing Characteristics (see IC spec for details)

6.1 Power On/Off Sequence

Power on Sequence

BOOSTM[1:0]=10 (Internal DC/DC power mode : Charge Pump, FP7721)

VCCD=IOVCC=VCCH=1.65V ~ 3.6V, VCI=VCIP=2.5V ~ 4.8V.

Power on:

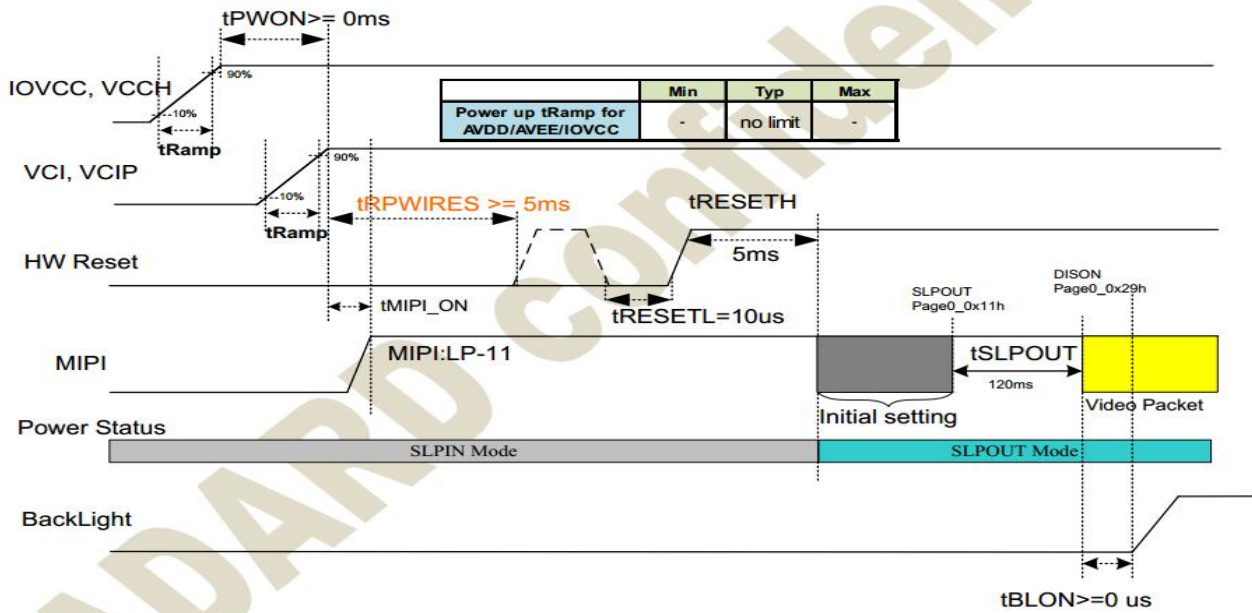

Power off Sequence

BOOSTM[1:0]=10 (Internal DC/DC power mode : Charge Pump, FP7721)
VCCD=IOVCC=VCCH=1.65V ~ 3.6V, VCI=VCIP=2.5V ~ 4.8V.
Power off: Case 1

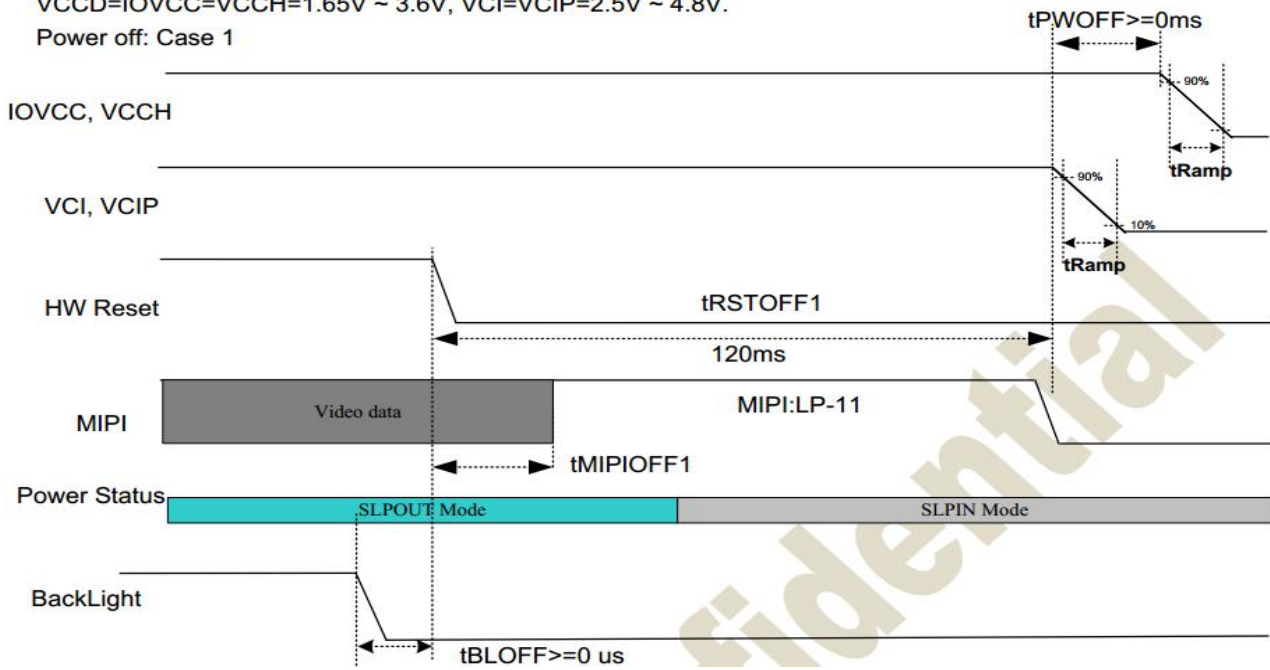

6.2 Timing Conditions

Resolution=800x1280(T_A=25°C, IOVCC=1.8V, VCIP=2.8V, VCI=2.8V)

Item	Symbol	Condition	Min.	Typ.	Max.	Unit
Vertical low pulse width	VS	-	2	4	200 Note(1)	Line
Vertical front porch	VFP	-	4	20	200	Line
Vertical back porch	VBP	-	2	10	200 Note(1)	Line
Vertical blanking period	VBK	VS+VBP+VFP	8	34	250	Line
Vertical active area	-	VDISP	-	1280	-	Line
Vertical Refresh rate	VRR	-	-	60	-	Hz

Note: (1) The VS and VBP pulse width are related to GIP start pulse and GIP clock pulse timing. The GIP start pulse and GIP clock pulse must be set at corresponding position for LCD normal display.

Resolution=800x1280 (T_A=25°C, IOVCC=1.8V, VCIP=VCI=VCCH=2.8V)

Item	Symbol	Condition	Min.	Typ.	Max.	Unit
HS low pulse width	HS	-	6	18	-	DCK
Horizontal back porch	HBP	-	5	18	-	DCK
Horizontal front porch	HFP	-	5	18	-	DCK
Horizontal blanking period	HBLK	HS+HBP+HFP	16	54 (Note1)	-	DCK
Horizontal active area	HDISP	-	-	800	-	DCK
Pixel Clock	PCLK	-	63.06 (Note2)	67.33 (Note2)	-	MHz

Note 1: HS+HBP > 0.5us.

Note 2: Pixel Clock = (HBLK+HDISP) * (VBK+VDISP) * Frame rate, Frame rate=60Hz.

7. Optical specifications

Item	Symbol	Condition	Values			Unit	Remark
			Min.	Typ.	Max.		
Viewing angle (CR≥ 10)	θ_L	$\Phi=180^\circ$ (9 o'clock)	-	80	-	degree	Note 1
	θ_R	$\Phi=0^\circ$ (3 o'clock)	-	80	-		
	θ_T	$\Phi=90^\circ$ (12 o'clock)	-	80	-		
	θ_B	$\Phi=270^\circ$ (6 o'clock)	-	80	-		
Response time Rise+Fall	T_{RT}	Normal $\theta=\Phi=0^\circ$	-	25	35	msec	Note 3
Contrast ratio	CR		80 0	100 0	-	-	Note 4
Color chromaticity	W_X		0.27 00	0.30 00	0.33 00	-	Note 2 Note 5 Note 6
	W_Y		0.29 00	0.32 00	0.35 00	-	
NTSC	Ratio		-	60	-	%	
Luminance	L		250	280	-	-	Note 6
Luminance uniformity	Y_U		9 点测试	70	75	-	%

Note 1: Definition of viewing angle

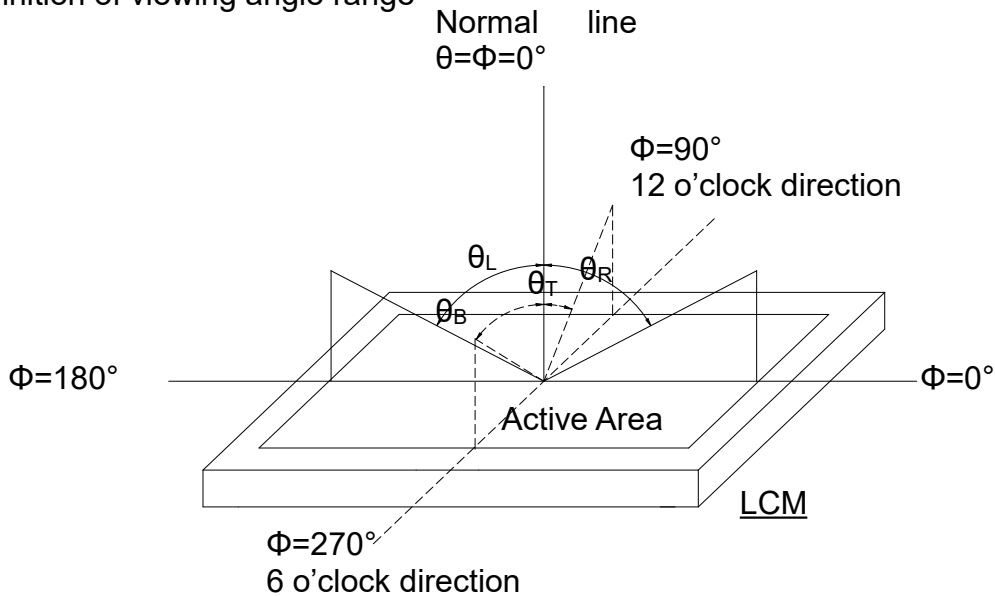

Fig. 4-1 Definition of viewing angle

Note 2: Definition of optical measurement system.

The optical characteristics should be measured in dark room. After 30 minutes operation, the optical properties are measured at the center point of the LCD screen. (Viewing angle is measured by ELDIM-EZ contrast/Height :1.2mm ,Response time is measured by Photo detector TOPCON BM-5A, other items are measured by BM-7A/Field of view: 1° /Height: 500mm.)

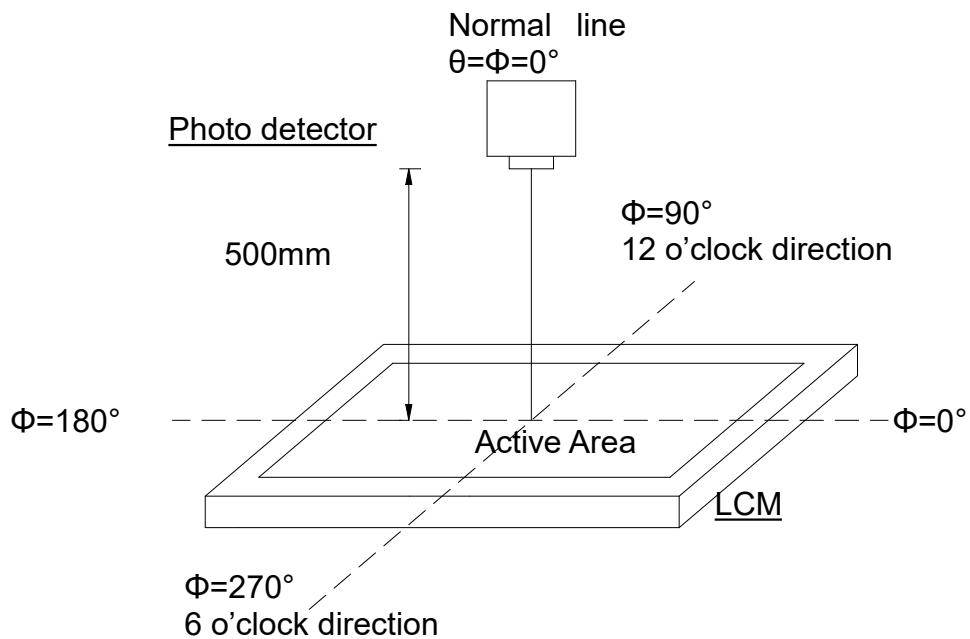

Fig. 4-2 Optical measurement system setup

Note 3: Definition of Response time

The response time is defined as the LCD optical switching time interval between "White" state and "Black" state. Rise time (T_{ON}) is the time between photo detector output intensity changed from 90% to 10%. And fall time (T_{OFF}) is the time between photo detector output intensity changed from 10% to 90%.

$$\text{Contrast ratio (CR)} = \frac{\text{Luminance measured when LCD on the "White" state}}{\text{Luminance measured when LCD on the "Black" state}}$$

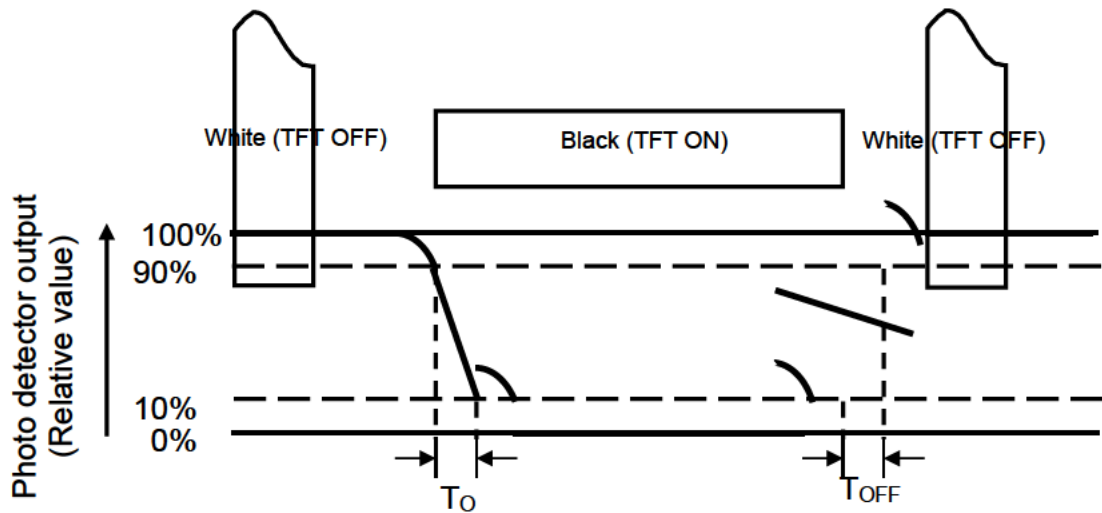

Fig. 4-3 Definition of response time

Note 4: Definition of contrast ratio

$$\text{Contrast ratio (CR)} = \frac{\text{Luminance measured when LCD on the "White" state}}{\text{Luminance measured when LCD on the "Black" state}}$$

Note 5: Definition of color chromaticity (CIE1931) Color coordinates measured at center point of LCD.

Note 6: All input terminals LCD panel must be ground while measuring the center area of the panel. The LED driving condition is $I_{LED} = 80 \text{ mA}$.

Note 7: Definition of Luminance Uniformity

Active area is divided into measuring areas (Refer to Fig. 4-4). Every measuring point is placed at the center of each measuring area.

$$\text{Luminance Uniformity (Yu)} = \frac{B_{min}}{B_{max}}$$

W-----Active area length H----- Active area width

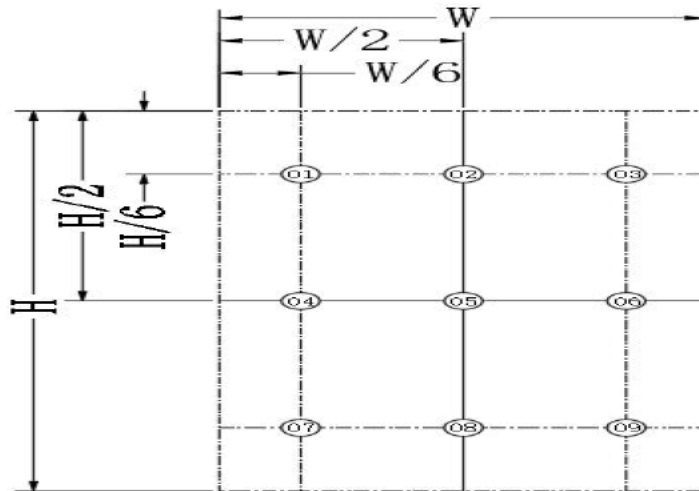

9点测试图

Fig. 4-4 Definition of measuring points

B_{max} : The measured maximum luminance of all measurement position.

B_{min} : The measured minimum luminance of all measurement position.

8. Reliability Test Conditions And Methods

Item	Test Conditions	Remark
High Temperature Storage	Ta=60.0°C 240.0hrs	
Low Temperature Storage	Ta=-20.0°C 240.0hrs	
High Temperature Operation	Ts=50.0°C 240.0hrs	
Low Temperature Operation	Ta=-10.0°C 240.0hrs	
Operate at High Temperature and Humidity	50.0°C,90.0%RH max 240.0hrs	Operation
Thermal Shock	-20.0 °C ~60.0 °C 10.0cycles 1.0Hrs/cycle	Non-operation
Electrostatic Discharge	Contact=±4.0KV,classB Air=±8.0KV,class B	

Note1: In the standard condition, there shall be no practical problem that may affect the display function. After the reliability test, the product only guarantees operation, but don't guarantee all of the cosmetic specification.

Note2: Before cosmetic and function test, the product must have enough recovery time, at least 2 hours at room temperature.

9. Handling Precautions

9.1 Mounting method

The LCD panel module consists of two thin glass plates with polarizers which easily be damaged. And since the module is so constructed as to be fixed by utilizing fitting holes in the printed circuit board.

Extreme care should be needed when handling the LCD modules.

9.2 Caution of LCD handling and cleaning

When cleaning the display surface, Use soft cloth with solvent [recommended below] and wipe lightly

- Isopropyl alcohol
- Ethyl alcohol

Do not wipe the display surface with dry or hard materials that will damage the polarizer surface.

Do not use the following solvent:

- Water
- Aromatics

Do not wipe ITO pad area with the dry or hard materials that will damage the ITO patterns

Do not use the following solvent on the pad or prevent it from being contaminated:

- Soldering flux
- Chlorine (Cl), Sulfur (S)

If goods were sent without being silicon coated on the pad, ITO patterns could be damaged due to the corrosion as time goes on.

If ITO corrosion happens by miss-handling or using some materials such as Chlorine (Cl), Sulfur (S) from customer, Responsibility is on customer.

9.3 Caution against static charge

The LCD module uses C-MOS LSI drivers, so we recommend that you:

Connect any unused input terminal to Vdd or Vss, do not input any signals before power is turned on, and ground your body, work/assembly areas, assembly equipment to protect against static electricity.

9.4 packing

- Module employs LCD elements and must be treated as such.
- Avoid intense shock and falls from a height.

- To prevent modules from degradation, do not operate or store them exposed direct to sunshine or high temperature/humidity

9.5 Caution for operation

- It is an indispensable condition to drive LCD's within the specified voltage limit since the higher voltage then the limit cause the shorter LCD life.
- An electrochemical reaction due to direct current causes LCD's undesirable deterioration, so that the use of direct current drive should be avoided.
- Response time will be extremely delayed at lower temperature then the operating temperature range and on the other hand at higher temperature LCD's how dark color in them. However those phenomena do not mean malfunction or out of order with LCD's, which will come back in the specified operation temperature.
- If the display area is pushed hard during operation, some font will be abnormally displayed but it resumes normal condition after turning off once.
- A slight dew depositing on terminals is a cause for electro-chemical reaction resulting terminal open circuit.

Usage under the maximum operating temperature, 50%Rh or less is required.

9.6 storage

In the case of storing for a long period of time for instance, for years for the purpose or replacement use, the following ways are recommended.

- Storage in a polyethylene bag with the opening sealed so as not to enter fresh air outside in it . And with no desiccant.
- Placing in a dark place where neither exposure to direct sunlight nor light's keeping the storage temperature range.
- Storing with no touch on polarizer surface by the anything else.
[It is recommended to store them as they have been contained in the inner container at the time of delivery from us

9.7 Safety

- It is recommendable to crash damaged or unnecessary LCD's into pieces and wash off liquid crystal by either of solvents such as acetone and ethanol, which should be burned up later.
- When any liquid leaked out of a damaged glass cell comes in contact with your hands, please wash it off well with soap and water

10. Precaution for use

10.1

A limit sample should be provided by the both parties on an occasion when the both parties agreed its necessity. Judgment by a limit sample shall take effect after the limit sample has been established and confirmed by the both parties.

10.2

On the following occasions, the handing of problem should be decided through discussion and agreement between responsible of the both parties.

- When a question is arisen in this specification
 - When a new problem is arisen which is not specified in this specifications
 - When an inspection specifications change or operating condition change in customer is reported , and some problem is arisen in this specification due to the change
 - When a new problem is arisen at the customer's operating set for sample evaluation in the customer site.
-

11. Package Drawing Packing Procedure

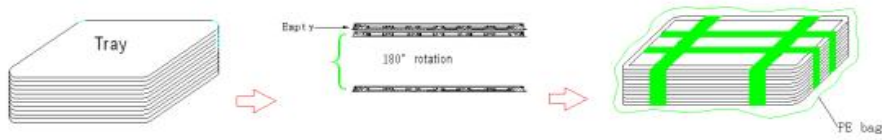

First step
 Putting products into the tray,
 LCD A.A faces Upward,
 (pay attention to the direction)

Second step
 Neighbouring trays should be
 staggered 180° while stacking up.
 on the top,there is an empty tray
 without product
 the quality of layers please refer to

Third step
 Taping up the tray after
 inspection, and put them
 into a PE bag

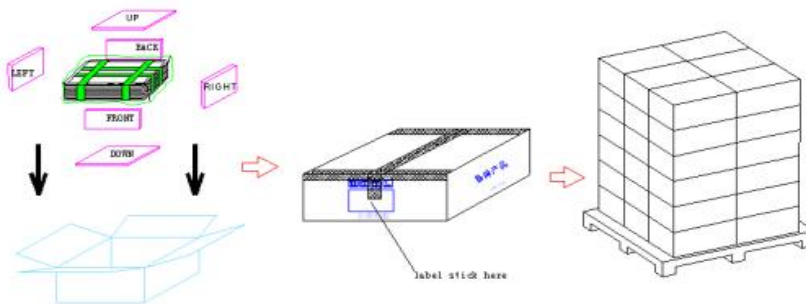

Fourth step
 Putting EPE foams and
 products with trays into the
 carton;
 Close the carton box

fifth step
 Sealing the carton with cellulose
 tape ;
 Stick on a carton label,

sixth step
 Placing the boxes together on a
 pallet (6 layers at most),

12. Outline Dimension

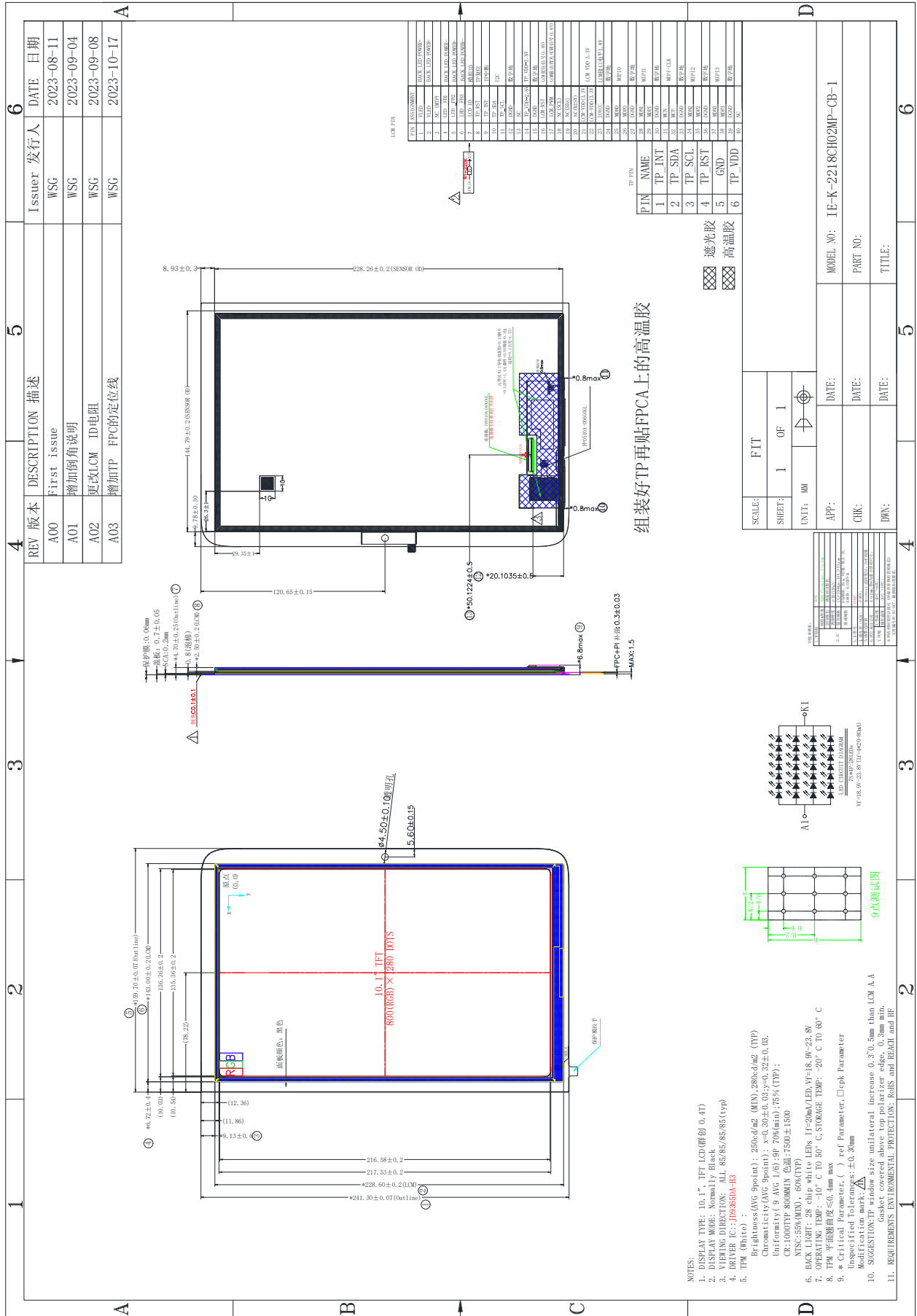

13. 条形码/二维码

14. HSF Requirements

- RoHS (Restriction of the use of certain Hazardous Substances)
 - HF (Halogen Free)
 - REACH (Regulation concerning the Registration, Evaluation, Authorization and Restriction of Chemicals)
 - Other regulations
-

Capacitive Touch Panel Specification

供应商确认栏 (Supplier Confirmation Column)

研发部 (The R & D Department)

制订: Formulate

审核: Check

批准: Approval

客户确认栏 (Customer Approval Column)

研发部 (The R & D Department)

品质部 (The Quality Department)

Contents 目录

Revision History 变更履历	
1. Scope 适用范围	
2. Structure Characteristics 结构特征.....	
3. Electrical Characteristics 电气特性.....	
4. Optical Characteristics 光学特性.....	
5. Environmental Characteristics 环境特性.....	
6. Reliability Conditions 可靠性条件.....	
7. Regulation on environment 环境法规.....	
8. Operating Precautions 使用注意事项.....	
9. Items concerning business 交易关联事项.....	
10. Structure 结构图	

Revision Record

Version	Date	Summary of Changes	Owner
A00	2019-12-5	Summary of Changes	-

1. Scope

--

2. Structure Characteristics

Item		Contents
2-1	VA Size VA 尺寸	10.1 Inch
2-2	Outline Dimension	159.700*241.300*159.700mm
2-3	Structure	GG
2-4	Materials	
2-5	Colour	Black
2-6	Total Weight	124g

3. Electrical Characteristics

Item 事项		Contents 内容
3-1	IC Type IC 型号	GT927
3-2	IC Package 封装方式	QFN
3-3	Channel Number 通道数	Rx31*Tx19
3-4	Interface 通信接口	I2C
3-5	Touch of points 触摸点数	5 Points
3-6	Input Mode 输入方式	Finger
3-7	Input Accuracy 输入精度	center area: $\pm 1.50\text{mm}$ edge area: $\pm 2.50\text{mm}$
3-8	Operating Voltage 工作电压 (AVDD;TYP)	2.80V
3-9	Interface Voltage 接口电压 (DVDD;TYP)	1.80V

3-10	Report Rate 报点频率	100Hz
3-11	Current Consumption 耗电量	25mA

4. Optical Characteristics 光学特性

4-1	Transparency 透过率	指示灯孔	无
4-1	Transparency 透过率	摄像孔区	85
4-1	Transparency 透过率	视窗区	85
4-2	Haze 雾度		无

5. Environmental Characteristics 环境特性

5-1	Operating Temperature 操作温度	-10~+50°C	Humidity: No dew condensation allowed. 湿度: 不允许结露。
5-2	Storage Temperature 保存温度	-20~+60°C	

6. Reliability Test Conditions 可靠性测试条件

Item 事项		Conditions 条件
6-1	High-temperature Storage 高温保存	T=60°C, 240H
6-2	Low-temperature Storage 低温保存	T=-20°C, 240H
6-3	High-temperature High-humidity Operation 高温高湿运行	T=60°C, 90%, 240H
6-4	Temperature Shock 温度冲击	20°C (30)min ← (10min Max.) → 60°C (30min) 120 cycles
6-5	High-temperature Operation 高温运行	50°C, 240H
6-6	Low-temperature Operation 低温运行	-10°C, 240H
6-7	Electro Static Discharge 抗静电测试	湿度: 30%~50%; 接触阻容: 100PF+1500ohm; 空气阻容: 150PF+330ohm; 测试次数: 正负各 10 次; 接触放电: ±6KV; 空气放电: ±8KV
6-8	Hardness 表面硬度	≥7H (750g)

Note: ① After the test is conducted under the above reliability conditions, the test pieces should be stored in the standard environment for 24 hours and the accuracy of input position given in para4-2 should be satisfied.

说明: 在进行条件以上可靠性试验后, 在标准状态环境下放置 24 小时, 必须满足 4-2. 输入精度。

② The reliability test should be performed with no D. C. power supplied and the touch panel stored on the flat plate.

可靠性试验是触摸屏在非通电、放置于平板上(水平放置)的状态下进行的测试。

- ③The standard condition presents $25\pm 10^{\circ}\text{C}$ of the temperature, $55\pm 30\%$ of the relative humidity, and $96\pm 10\text{ kPa}$ of the atmospheric pressure.
所谓标准状态, 温度: $25\pm 10^{\circ}\text{C}$ 、相对湿度: $55\pm 30\%$ 、气压: $96\pm 10\text{Kpa}$ 。
- ④The reliability test should be performed on the touch panel by itself.
对触摸屏单体实施测试

7. Regulation on environment 环境法规

7-1. RoHS directive RoHS 指令

This product is corresponded to RoHS directive.

“Corresponded to RoHS directive” is judged based on EU Directive RoHS 2011/65/EU.

本产品符合 RoHS 指令, 遵循欧盟 RoHS 2011/65/EU 的指令。

7-2. Other 其他

Requirement for the other restricted material needs to be cleared and it should be decided on discussion between our customer and us.

对于其他限制物质的要求应该说明, 依商讨内容为准。

8. Operating Precautions 使用注意事项

8-1. Chassis Mechanical Design 框体结构设计

- a. Please use the touch panel as a replaceable unit when you are designing your product.
(Please do not consider the touch panel as a permanent item.)
设计时请将触摸屏作为可更换的部件来考虑 (将触摸屏作为寿命产品来考虑)。
- b. Assuming input method for customers' use, design the chassis so that no chassis strain or the like has an influence on the touch panel by the hand placed on the chassis, for example.
考虑到用户的使用时的状态, 例如, 当把手压到框体时要确保不会对触摸屏产生影响。
- c. Select insulation material when considering construction material for the chassis.
It may lead to a cause of false operation when conductive material is used as the chassis.
请选择绝缘的材料作为框体, 使用导电性材料可能会引起误动作。
- d. When inserting a spacer (such as a cushioning material) between the touch panel and chassis for the purpose of dust proofing, pay attention to the following:
以防尘为目的在触摸屏和框体之间夹放垫片 (缓冲材) 时, 要注意以下几点:
 - (1) Fix a spacer to the chassis side: avoid bonding it to the touch panel.
缓冲材要固定在框体侧, 而不要粘贴在触摸屏上。
 - (2) Select insulation materials as the spacer and locate it outside of key area.
选择绝缘的材料作为缓冲材, 且要置于键入区外部
- e. When distance with the touch panel is near to LCD, Touch panel may malfunction by the influence of the noise from LCD; the touch panel's structure may be different according to the LCD's type. When using a VCOM type LCD, A shielding Layer is recommend.
当触摸屏与 LCD 距离太近时, 触摸屏可能会因 LCD 的噪音产生误动作; 根据液晶类型的不同, 触摸屏的结构可能有所不同。当使用 VCOM 类型的液晶时, 建议使用有屏蔽层结构的设计。
- f. Pay attention for not to make any stress of deformation.
请注意不要施重压而使触摸屏变形。
- g. Avoid performing adhesion with the touch panel inclined or uneven.
This inclination and shift may lead to positional deviation at input.
请避免触摸屏和 LCD 贴合的倾斜和不平行, 这种倾斜和偏移可能会造成输入的偏移

8-2. Flexible Connector FPC 连接器

- a. The effective part for the attachment of flexible connector and the touch panel main body
-

should be the deflection of R=3.0mm or more.

FPC 上的附件的有效组成部分和触摸屏本体应该有 R 3.0mm 或更大 的扰度。

b. For flexible connector arrangement, R=2.0mm or more should be maintained so that the circuitry will not crease.

对于 FPC 的组装, 应该有 R 2.0mm 或更大的扰度, 这样就线路就不会起褶皱

c. Please do not bend the chip mounting area.

不要弯曲芯片放置位置

d. For the connector side of the FPC:关于 FPC 连接器侧

(1) If the pressure in the contact part of circuit side connector and flexible connector wiring is too large, there may arise deflection in the wiring, that could cause contact failure; it is, therefore, necessary to verify the impact of the connector on the FPC as well as the influence of thermal stress, etc. Using the actual machine before selecting the connector; 如果在 FPC 接触部的压力过大, 有可能会 出现偏移而造成接触失效; 所以有必要用实物验证连接器的压力及热影响;

(2) After checking the applicable conductor, select the circuit side connector.

The general connector for FPC is designed, assuming the metallic wiring; some connectors are large in pressure in the contact part and sharp in shape.

在确定了可用的 FPC 连接器后, 再选择 FPC.

8-3. Touch Panel Handling 触摸屏的使用

Handing 拿取	(1) Do not lift up the product by holding the flexible connector. 请不要手持 FPC 来提取产品。
Installation 组装	(1) Since the glass substrate has some sharp edges, use fingerstalls or gloves, etc., and handle with special care. 请注意: 因为有锐利的部分, 必须在戴指套, 手套等的情况下使用。 (2) Note that if the flexible connector is pressed against the glass edge, electrode disconnection or burnout may occur. 请注意: 如果把 FPC 按压在玻璃端面有可能会造成断线的现象。
Unpacking 拆卸	(1) Always remove the touch panel for maintenance after satisfactory cooling. 请确保触摸屏在完全冷却的状态下进行拆装与维修。
Cleaning 清洁	(1) When re-adhering the protecting film, check for stains. These stains can be transferred. 将产品的保护膜重新贴上时, 请确认保护膜上是否有污, 因为有可能产生转写污。 (2) If the touch panel is stored with the protecting film attached for a long period of time, the pressure sensitive adhesive of protecting film may stick to the touch panel as stains. Lightly wipe out the stains with a soft moistened cloth in ethanol. 贴上保护膜长时间保存时, 会造成保护膜上的粘着剂形成污转写到触摸屏表面。若表面有转写污, 请用软布, 沾少量酒精轻擦掉此污。 (3) Do not apply water or chemicals other than alcohol such as ethanol to the touch panel. In particular, do not allow liquid put on the touch panel face side. 请不要在触摸屏上沾酒精以外的化学药品及水。特别是触摸屏的端面不能附着液体。
Storage 保存	(1) Store the touch panel indoor in the packing case (in the condition in which it was delivered) at 10°C or higher, 40°C Max. and below 60% in humidity. The glue of touch panel protecting film may possibly be transferred as stains. 包装好的产品 (交货时的状态), 在 10°C 以上 40°C 以下、湿度 60% 以下的环

	<p>境下 保存。请注意：产品若长期放置，保护膜的胶有可能变成污转写到触摸屏上。</p> <p>(2) Do not store the touch panel in a high temperature and humidity for a long period of time and avoid storage in the environment where condensation could arise. 请不要长期保存在高温高湿环境下。特别是绝不能保存在会产生结露的环境中。</p>
Other 其它	<p>(1) Do not store nor use under outside and UV exposing environment like mercury light bulb, permanently because serious performance damage may occur. Touch panel has a certain life, so life is different depending on your usage circumstance. 请避免触摸屏，在屋外及有水银灯等紫外线照射的环境下长期放置和使用，因为这会对其性能产生很大的影响。触摸屏是有寿命的产品，且因使用环境的不同而变化。</p> <p>(2) Be careful of dew occurring in case there is difference of temperature between outside and inside of device (i.e. display monitor). If dew may occur, electrical shortage between electrode. And/or deterioration of conductive layer may happen. 请注意：当外部温度和机械内部温度（表示装置等）有温差时、容易产生结露。如果发生结露，有可能导致上下电极间发生短路及电阻膜劣化的现象。</p> <p>(3) Operating temperature is under installed inside equipment without relating on or off status. Non operating temperature means the status of touch panel alone. 动作温度是指触摸屏实装于产品状态下的温度（与通电与否无关）。非通电温度是指触摸品单体状态时的温度。</p>

9. Items concerning business 交易关联事项

9-1. Warranty Period and Warranty Range 保证期限及保证范围

(1) Warranty period 保证期限

One year after the date of delivery. 交付后一年。

(2) Warranty range 保证范围

If Touch Panel is failed and damaged due to our company's cause within the warranty period, we will repair or replace it.

保证期限内, 由于本公司的原因导致的故障、损伤时, 我司将进行修理或更换新的良品。

As far as compensation, repair or replacement should be limited to our delivered touch panel itself. Damage induced due to delivered touch Panel failure is out of our warranty. The repair or replacement in the field are also out of our warranty.

另外, 关于补偿, 只对交付品(触摸屏的单体)的实物进行交换。

由于产品的故障而引发相关损害以及在当地进行维修、更换的所引起的相关费用, 本公司一律不给予补偿。

The assurance range and time of environmental characteristics reference to reliability conditions of the No.7.

环境特性的保证范围和时间以第7项可靠性试验为准。

The following cases are excluded from the warranty range:

下述情况不属于本公司的保证范围。

- (a) Failure and damage caused by handling nonconformities, such as drop and shocks during transportation (movement) after delivery
交付后，由于贵公司的使用不当（如移动，运输时的跌落、撞击等）而引起的故障、损伤的情况。
- (b) Failure and damage caused by disasters
天灾等因灾害引起的故障、损伤的情况。
- (c) Repair and modification at other than our company
非经本公司进行的修理而被改造了的情况。
- (d) Failure and damage caused by handling contrary to “Touch Panel Operating Precautions” described in this Specification.
违反本规格说明书中所记载了的使用方法及注意事项而引起的故障、损伤的情况。

9-2. Remarks 备注

- (1) Once your company receive this specification, if no confirmation and signing back without reasonable notice within 15 days, we will consider it to be self-executing.
贵公司收到本规格书 15 日内，若因贵公司原因一直没有正式确认、回签，我司则视为自动生效。
 - (2) The discription above is translated from Chinese version. If you have any questions, please kindly refer to the Chinese version. Any inconvenience, please kindly forgive us.
以上英文描述均为中文翻译成英文的内容，若有不明处，请以中文版的说明书内容为准。若有不便，敬请谅解！
-