

PRODUCT SPECIFICATION

规格书

Customer Name 客户名称	
Customer Project Name 客户项目名	
Part NO 产品型号	IE-M-0706CV09P16-00-1
Remarks 备注栏	<input type="checkbox"/> APPROVAL FOR SPECIFICATION ONLY <input checked="" type="checkbox"/> APPROVAL FOR SPECIFICATION AND SAMPLE

CUSTOMER					
APPROVED	CHECKED	CHECKED	APPROVED	CHECKED	PREPARED
					宋啟明

Revision Record

修改记录

Rev No	Date	Description
版本号	时间	内容
V1.0	2020-7-29	Preliminary Specification Release.

Contents

- 1 General specification**-----基本规格
- 2 LCM-Pin Assignment**-----接口定义描述
- 3 Mechanical Drawing**-----模组图
- 4 Electrical Specification**-----电气特性
- 5 Outgoing inspection standard**-----出货检验标准
- 6 Reliability Test Items** -----可靠性测试项目
- 7 Suggestions for using LCD modules**-----使用注意事项
- 8 Packing and Storage Specification(Reference Only)**
-----包装存储

1. General Specifications 基本规格

项目 Item	规格标准值 Main Display	单位 Unit
显示点阵数 Number of Pixels	240 * RGB * 320	Pixel
LCM 外型尺寸 LCM Outline Dimension	47.4 (W) * 65.95 (H) * 2.18 (T)	mm
LCD 尺寸 LCD Outline Dimension	46.2 (W) * 64.75 (H) * 0.8 (T)	mm
LCD 动态显示区 Active Area	43.2 * 57.6	mm
像素尺寸 Pixel Pitch	0.180 * 0.180	mm
显示方式 Display Mode	Normal Black	
像素成分 Pixel Arrangement	R.G.B Vertical Stripe	
视角 Viewing Direction	Free	
颜色排列 Color Configuration	RGB	
LCD 透过率 LCD Transmittance	Typ:3.9%;	
LCD 对比度 LCD Contrast Ratio	Typ:800; Min:600;	
FPC 版本 FPC Version		
接口 Interface	MCU	
工作温度 Operating Temperature	-20°C ~ 70°C	
储存温度 Storage Temperature	-30°C ~ 80°C	
背光排列方式 Backlight arrangement	LED / 6 串	
亮度 Luminance	-	
重量 Weight	-	

准亿科技只能承诺： 同一批次产品的一致性，不承诺批次与批次之间的一致性。

2.LCM-Pin Assignments 接口定义描述

引脚号	引脚定义	功能说明
1	LED-A	POWER SUPPLY+ FOR BACKLIGHT
2	LED-K	POWER SUPPLY- FOR BACKLIGHT CATHODE
3	GND	Ground
4	VDD	POWER SUPPLY (3.3V)
5	VDDI	POWER SUPPLY (1.8V)
6	GND	Ground
7	B17	MCU parallel interface data bus.
8	B16	MCU parallel interface data bus.
9	B15	MCU parallel interface data bus.
10	B14	MCU parallel interface data bus.
11	B13	MCU parallel interface data bus.
12	B12	MCU parallel interface data bus.
13	B11	MCU parallel interface data bus.
14	B10	MCU parallel interface data bus.
15	B7	MCU parallel interface data bus.
16	B6	MCU parallel interface data bus.
17	B5	MCU parallel interface data bus.
18	B4	MCU parallel interface data bus.
19	B3	MCU parallel interface data bus.
20	B2	MCU parallel interface data bus.
21	B1	MCU parallel interface data bus.
22	B0	MCU parallel interface data bus.
23	GND	Ground
24	RD	Read strobe signal.
25	WR	Write strobe signal.
26	RS	Ground
27	CS	Chip selection signal.
28	IM0	IM0 为 0 时, 16 位 MCU (B0-B7,B10-B17) IM0 为 1 时, 高 8 位 MCU (B10-B17),B0-B7 接 GND
29	RESET	Reset Signal pin (1.8V)
30	GND	Ground

注: RESET 电压需要与 VDDI 电压一致, 如果电压不同, 会有概率出现开机黑屏现象。

3.Mechanical Drawing 模组图

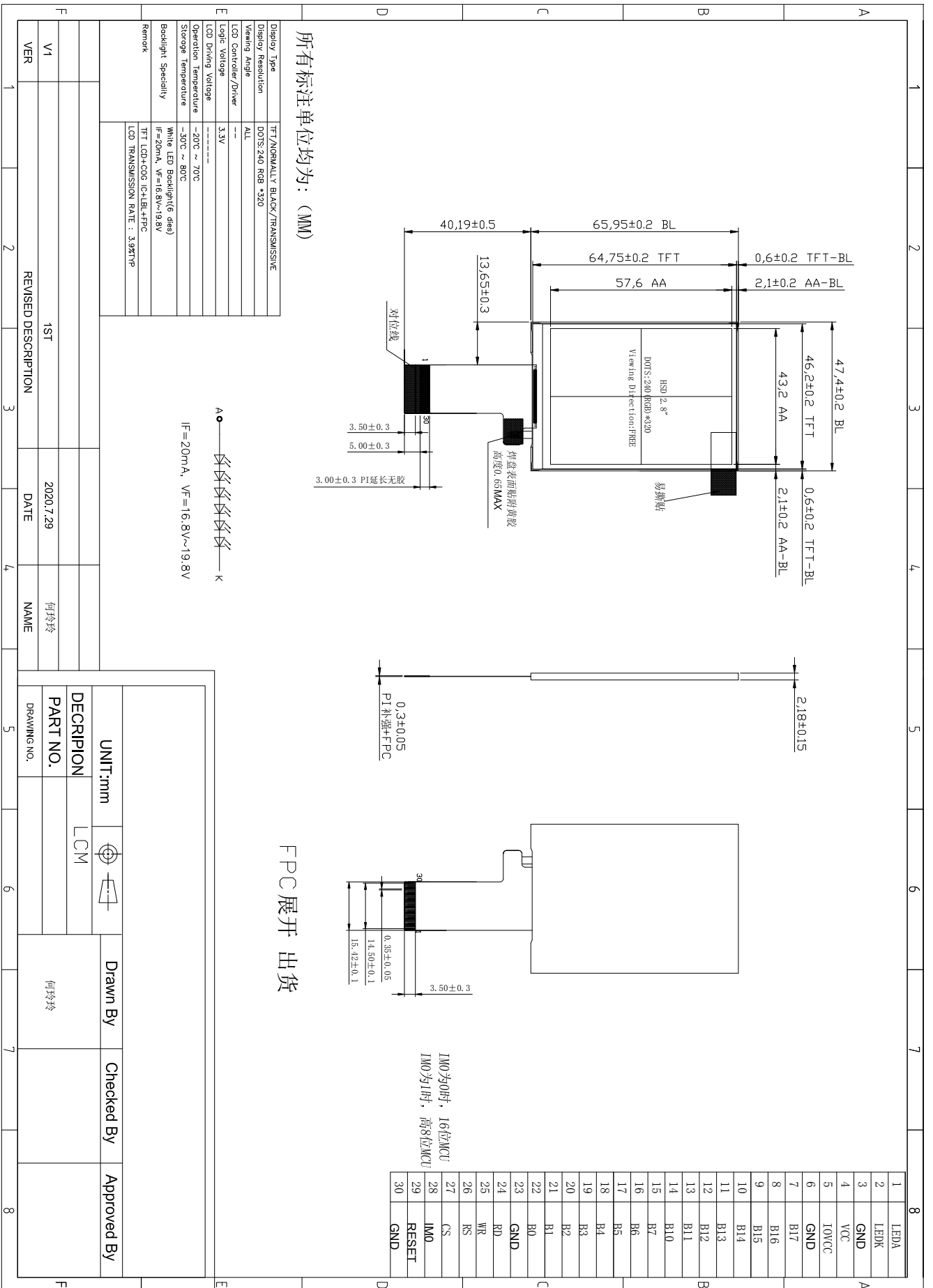

4. Electrical Specification 电气特性

4.1 DC Characteristics 直流特性

Item 项目	Symbol 符号	Specification 规范			Unit 单位
		Min	Typ	Max	
TFT gate on voltage 驱动高电压	VGH	12.5	13.5	14.5	V
TFT gate off voltage 驱动低电压	VGL	-9	-8	-7	V
TFT common electrode Voltage 电极电压	Vcom H	-2	-	3	V

4.2 Typical Operation Conditions 典型工作条件

Item 项目	Symbol	Min.最小	Typ.典型	Max.最大	Unit
Analog Supply Voltage 模拟供电电压	VCI	2.4	2.8	3.3	V
Digital Supply Voltage 数字电源电压	VDD	2.4	2.8	3.3	V
I/O Supply Voltage 接口电压	IOVCC	1.65	1.8	3.3	V
Input High Voltage 输入高电平	VIH	$0.8 \cdot IOVCC$	-	IOVCC	V
Input Low Voltage 输入低电平	VIL	0	-	$0.2 \cdot IOVCC$	V
Output High Voltage 输出高电平	VOH	$0.8 \cdot IOVCC$	-	-	V
Output Low Voltage 输出低电平	VOL	-	-	$0.2 \cdot IOVCC$	V

4.3 Backlight Circuit Characteristics 背光功耗

Item	Symbol	Min.	Typ.	Max.	Unit
LED Current 背光电流	I _B	-	20	-	mA
LED Voltage 背光电压	V _f	16.8	18	19.8	V
Power Consumption 功耗	P _{BL}	-	360	-	mW

4. 4 LCD Current Consumption 液晶面板功耗

Item	Symbol	Typ.	Max.	Unit
Full Mode 正常模式	VCI+IOVCC	–	–	mA
测试条件: VCI=2.8V, IOVCC=1.8V; Interface 驱动类型: 行翻转或者列翻转; IPS Type=>All Black Pattern. IPS型液晶面板=>黑色画面; TN Type=>All White Pattern. TN型液晶面板=>白色画面; Temperature: 25℃; 温度: 室温25摄氏度;				
Sleep Mode 休眠模式	VCI+IOVCC	–	–	uA
测试条件: VCI=2.8V, IOVCC=1.8V; DC/DC converter is enabled. Internal oscillator is started and panel scanning is started. 除IC内部晶振和面板扫描外, 其他功能都暂停工作; Temperature: 25℃; 温度: 室温25摄氏度;				

4. 5. Measurement system 测量系统

4. 5. 1 LCM Viewing Angle

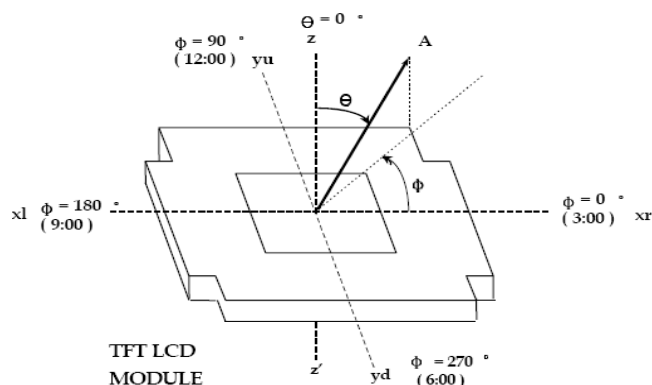

Viewing angle is the angle at which the contrast ratio is greater than 10. The angles are determined for the horizontal or x axis and the vertical or y axis with respect to the z axis which is normal to the LCD surface.

4.5.2 Response time

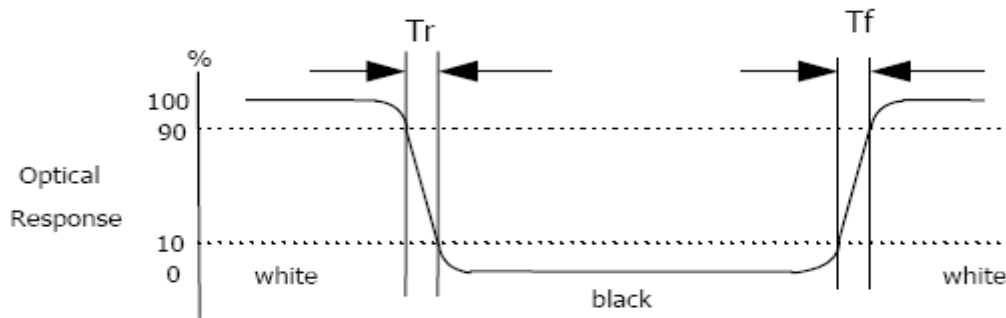

Response time is the time required for the display to transition from white to black (Rising time, T_r) and from black to white (Falling time, T_f) for additional information.

4.5.3 Contrast Ratio (CR)

Contrast Ratio (CR) is defined mathematically as:

$$\text{Contrast Ratio} = \frac{\text{Surface Luminance with all white pixels}}{\text{Surface Luminance with all black pixels}}$$

Surface luminance is the center point across the LCD surface 500mm from the surface with all pixels displaying white.

4.6 Power ON/OFF Sequence 上电开/关时序

VDDI and VDD can be applied in any order.

VDD and VDDI can be power down in any order.

During power off, if LCD is in the Sleep Out mode, VDD and VDDI must be powered down minimum 120msec after RESX has been released.

During power off, if LCD is in the Sleep In mode, VDDI or VDD can be powered down minimum 0msec after RESX has been released.

CSX can be applied at any timing or can be permanently grounded. RESX has priority over CSX.

Note 1: There will be no damage to the display module if the power sequences are not met.

Note 2: There will be no abnormal visible effects on the display panel during the Power On/Off Sequences.

Note 3: There will be no abnormal visible effects on the display between end of Power On Sequence and before receiving Sleep Out command. Also between receiving Sleep In command and Power Off Sequence.

Note 4: If RESX line is not held stable by host during Power On Sequence as defined in the sequence below, then it will be necessary to apply a Hardware Reset (RESX) after Host Power On Sequence is complete to ensure correct operation. Otherwise function is not guaranteed.

The power on/off sequence is illustrated below

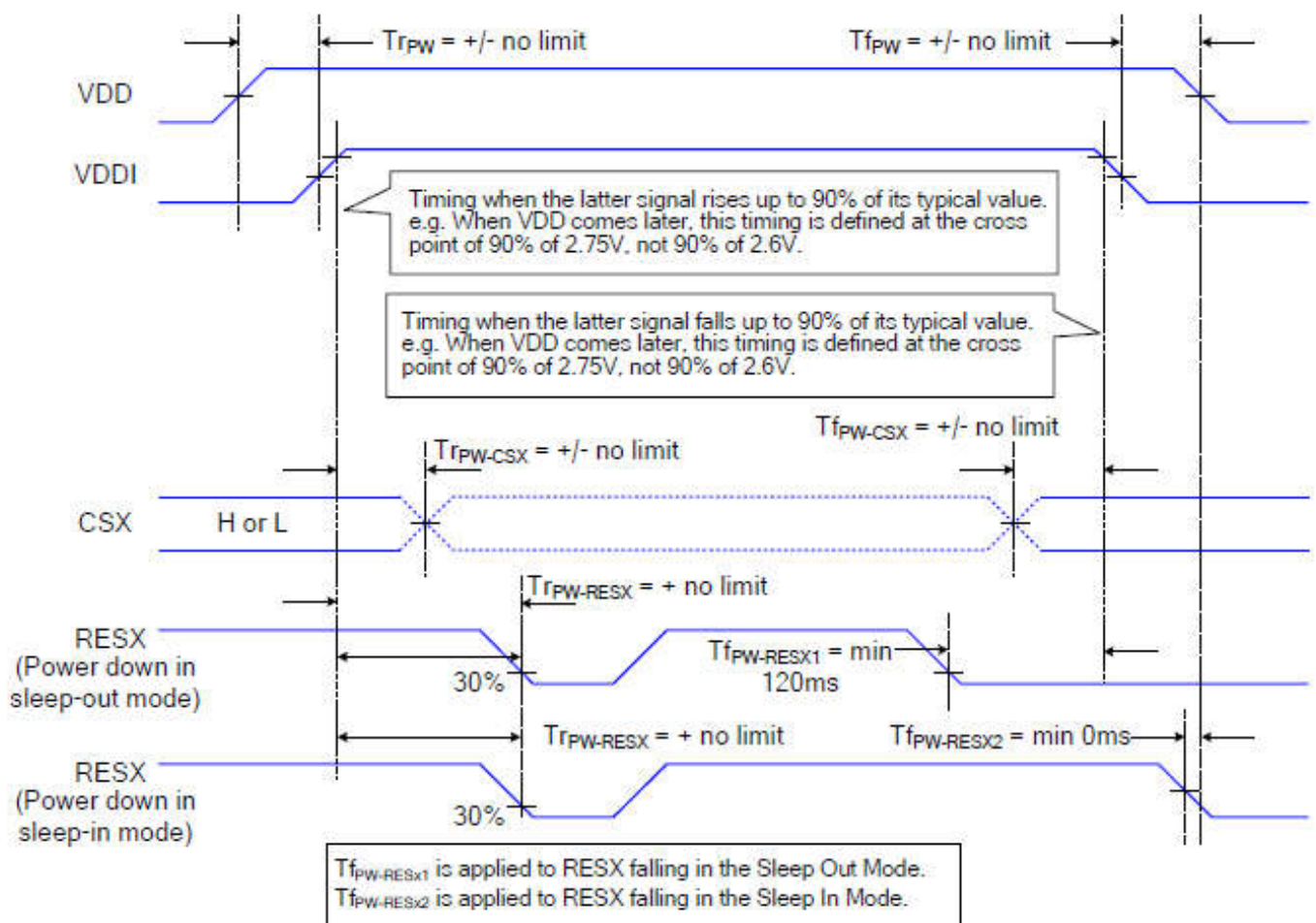

5. Outgoing inspection standard 出货检验标准

序号 /Serial number	缺陷内容 /Defect content	判定基准 /Judgment criteria		缺陷等级 /Defect grade	判定结果 /Judgmen t result
1	点状缺陷 (含亮点/ 彩点/气泡 /黑点等) /Spot defects (including bright spots / color spots / bubbles / black spots, etc.)	7寸以内 (不含 6.95和7 寸) /Within 7 inches (excludi ng 6.95 and 7 inches)	$\Phi \leq 0.15\text{mm}$ 。	忽略不计 /Ignore	OK
			$0.15\text{mm} < \Phi \leq 0.20\text{mm}$, $DS \geq 10\text{mm}$, 数量不限。/Unlimited number.	轻微缺陷 /Minor defects	OK
			$\Phi > 0.20\text{mm}$ 。	严重缺陷 /Serious defect	NG
		7寸以上 (含6.95 和7寸) /More than 7 inches (includi ng 6.95 and 7 inches)	$\Phi \leq 0.20\text{mm}$ 。	忽略不计 /Ignore	OK
			$0.20\text{mm} < \Phi \leq 0.30\text{mm}$, $DS \geq 10\text{mm}$, 数量不限。/Unlimited number.	轻微缺陷 /Minor defects	OK
			$\Phi > 0.30\text{mm}$ 。	严重缺陷 /Serious defect	NG
Φ 表示缺陷直径, DS表示间距。 / Φ refers to defect diameter, DS refers to spacing.					
2	线状缺陷 (划伤、毛 丝等) /Linear defects (scratche s, filaments , etc.)	7寸以内 (不含 6.95和7 寸) /Within 7 inches (excludi ng 6.95 and 7 inches)	$W \leq 0.03\text{mm}$, L不限。/L is not limited.	忽略不计 /Ignore	OK
			$0.03\text{mm} < W \leq 0.05\text{mm}$, $L \leq 3\text{mm}$, DS $\geq 10\text{mm}$, 数量不限。/Unlimited number.	轻微缺陷 /Minor defects	OK
			$W > 0.05\text{mm}$	严重缺陷 /Serious defect	NG

		7寸以上 (含6.95和7寸) /More than 7 inches (including 6.95 and 7 inches)	W≤0.03mm, L不限。/L is not limited.		忽略不计 /Ignore	OK
			0.03mm<W≤0.05mm, L≤5mm, DS≥10mm, 数量不限。/L is not limited.		轻微缺陷 /Minor defects	OK
			W>0.05mm		严重缺陷 /Serious defect	NG
		W表示缺陷宽度, L表示缺陷长度, DS表示间距。 /W is the defect width, l is the defect length and DS is the spacing.				
3	偏光片气泡 /Polarizer bubble	显示区 /Display area	按点状缺陷判定 /Judged by point defects			
		黑边区 /Black border area	未在显示区边缘往外扩展0.5mm内。 /It does not extend within 0.5mm from the edge of the display area.		轻微缺陷 /Minor defects	OK
			在显示区边缘往外扩展0.5mm内。 /Extend 0.5mm from the edge of the display area.		按点状缺陷判定 /Judged by point defects	
4	偏光片凹凸点(印) /Concave convex point of polarizer (print)	显示区/ 黑边区 /Display area / black border area	正常组装触摸屏或盖板后不可见。 /It is not visible after the touch screen or cover plate is assembled normally.		轻微缺陷 /Minor defects	OK
5	色彩和亮度 /Color temperature and Luminance	管控项目	管控方法	管控设备	中间值	公差范围
		色彩	X, Y 的色坐标	光学仪器 BM-7	按客户确认的 样品实测	±0.04
		亮度	取9点亮度EV 求平均值	光学仪器 BM-7	按客户确认的 样品实测	±20%
6	其它标准 /Other standards	按双方沟通报价为准。 /According to the quotation negotiated by both parties.				
7	质保期 /Warranty period	售后质保期一年。 /After sales warranty period is one year.				

6. Reliability Test Items 可靠性测试项目

Test Item 测试项目	Test Condition 测试条件	Test result determinant gist 实验结果判定
High temperature storage 高温存储	80°C , 240H ;	Inspection after 2~4hours storage at room temperature, the sample shall be free from defects: 试验结束后, 已测试的LCD 样品必须在室内正常温湿 度环境下放置2~4个小时以上 才能进行功能和外观检查, 样 品不允许有以下缺陷: 1.Air bubble in the LCD; 模块中有气泡; 2.Non-display; 不显示; 3.Glass crack; 玻璃破碎; 4. The electrical characteristics requirements shall be satisfied. 需要满足模块电气性能。
Low temperature storage 低温存储	-30°C , 240H ;	
High temperature operation 高温运行测试	70°C , 240H ;	
Low temperature operation 低温运行测试	-20°C , 240H ;	
High temperature /humidity 高温高湿	60°C,90%RH , 240H ;	
Thermal Shock 冷热冲击	-30°C/0.5h~+80°C/0.5h for a total 24 cycles ;	
Vibration Test 振动测试	Frequency 10Hz~55Hz~10Hz Amplitude : 0.75mm, X , Y , Z direction for total 1H ; (Packing condition)	
ESD test 静电测试	±3KV, Human Body Mode, 150pF/330Ω ; ±6KV, Air Mode, 150pF/330Ω ;	

Remark: 注意:

1. The test samples should be applied to only one test item.

每个被测试的模块只能用于其中的一个测试项目。

2. Sample size for each test item is 2pcs.

每个测试项目的样品数量为2片。

3. Failure Judgment Criterion: Basic Specification, Electrical Characteristic, Mechanical Characteristic, Optical Characteristic.

故障判断标准:基本规格, 电气特性, 机械特性, 光电特性。

7. Suggestions for using LCD modules 使用注意事项

7.1 The display panel is made of glass and polarizer. As glass is fragile. It tends to become or chipped during handling especially on the edges. Please avoid dropping or jarring. Do not subject it to a mechanical shock by dropping it or impact.

显示屏由玻璃和偏光片组成。由于玻璃是脆的, 使用过程中要特别注意边缘区。请防止跌落或振动。不能机械碰撞。

7.2 If the display panel is damaged and the liquid crystal substance leaks out, be sure not to get any in your mouth. If the substance contacts your skin or clothes, wash it off using soap and water.

如果显示屏损坏且液晶物质泄漏, 切勿入口。如果液晶物质与皮肤或衣服接触, 请使用肥皂和水冲洗。

7.3 Do not apply excessive force to the display surface or the adjoining areas since this may cause the color tone to vary. Do not touch the display with bare hands. This will stain the display area and degraded insulation between terminals (some cosmetics are determined to the polarizer).

请勿施加过大的压力于显示屏或连接部位, 否则会引起色调变化。不要用手接触显示屏, 这将弄脏显示区和降低端子之间的绝缘能力(一些外观是由偏光片决定的)。

7.4 The polarizer covering the display surface of the LCD module is soft and easily scratched. Handle this polarizer carefully. Do not touch, push or rub the exposed polarizers with anything harder than an HB pencil lead (glass, tweezers, etc.). Do not put or attach anything on the display area to avoid leaving marks on it. Condensation on the surface and contact with terminals due to cold will damage, stain or dirty the

polarizer. After products are tested at low temperature they must be warmed up in a container before coming in to contact with room temperature air.

覆盖液晶显示模块显示平面的偏光片是软性且易被擦伤，请小心轻拿。请勿用任何硬度大于 HB 铅笔芯的物品（玻璃，镊子等）接触、撞压或摩擦裸露偏光片。不要放置或粘附物体在显示区域上以免留下痕迹。冷凝在表面和端子将会损坏或弄脏偏光片。产品在低温下测试之后，与室温空气接触之前必须在容器内升温。

7.5 If the display surface becomes contaminated, breathe on the surface and gently wipe it with a soft dry cloth. If it is heavily contaminated, moisten cloth with one of the following solvents

- Isopropyl alcohol
- Ethyl alcohol

Do not scrub hard to avoid damaging the display surface.

如果显示平面受污，可对平面吹热气且轻轻地用软性干布擦除。如果受污严重，用含下列一种溶剂的湿布擦除：

- 甘油
- 酒精

请勿用力擦拭以免损坏显示平面。

7.6 Solvents other than those above-mentioned may damage the polarizer. Especially, do not use the following.

- Water
- Ketone
- Aromatic solvents

Wipe off saliva or water drops immediately, contact with water over a long period of time may cause deformation or color fading. Avoid contact with oil and fats.

除以上提到的溶剂外，其他溶剂可能会损坏偏光片，特别要避免使用以下溶剂：

- 水
- 酮
- 芳烃溶剂

立即擦掉唾液或水滴，长时间与水接触会引起变形或褪色。避免接触油和油脂。

7.7 Exercise care to minimize corrosion of the electrode. Corrosion of the electrodes is accelerated by water droplets, moisture condensation or a current flow in a high-humidity environment.

特别注意最小限度地减少电极腐蚀，电极腐蚀会因水滴、湿度冷凝或高湿环境下通电而加速。

7.8 Install the LCD Module by using the mounting holes. When mounting the LCD module make sure it is free of twisting, warping and distortion. In particular, do not

forcibly pull or bend the I/O cable or the backlight cable.

使用安装孔装配液晶显示模块，安装时一定不要弯曲、扭曲和变形。要特别注意不要用力拔，弯曲传输线或背光线。

7.9 Do not attempt to disassemble or process the LCD module.

请勿拆卸液晶显示模块。

7.10 NC terminal should be open. Do not connect anything.

悬空端应断开，不要连接任何器件。

7.11 If the logic circuit power is off, do not apply the input signals.

如果逻辑电路电源是断开的，不要施加输入信号。

7.12 Electro-Static Discharge Control , Since this module uses a CMOS LSI, the same careful attention should be paid to electrostatic discharge as for an ordinary CMOS IC. To prevent destruction of the elements by static electricity, be careful to maintain an optimum work environment.

由于液晶显示模块使用 CMOS 集成，要特别注意静电放电问题。对 CMOS 器件，要特别注意静电。为防止静电损坏，注意保持合宜的工作环境。

- Before removing LCM from its packing case or incorporating it into a set, be sure the module and your body have the same electric potential. Be sure to ground the body when handling the LCD modules.

-液晶显示模块移出包装盒和安装之前，要保证模块和人体具有相同的电位。处理模块时，可靠接地。

- Tools required for assembling, such as soldering irons, must be properly grounded. Make certain the AC power source for the soldering iron does not leak. When using an electric screwdriver to attach LCM, the screwdriver should be of ground potentiality to minimize as much as possible any transmission of electromagnetic waves produced sparks coming from the commutator of the motor.

- 使用工具如电烙铁，要可靠接地，并确保烙铁使用交流电，不要漏电。用电批固定模块时，电批应接地，尽可能降低电动换向器火花产生的电磁波。

- To reduce the amount of static electricity generated, do not conduct assembling and other work under dry conditions. To reduce the generation of static electricity be careful that the air in the work is not too dry. A relative humidity of 50%-60% is recommended. As far as possible make the electric potential of your work clothes and that of the work bench the ground potential.

- 为减少静电产生，不在干燥组装或其它操作。为降低静电，工作场地一定不要

太干燥。建议相对湿度为 50%–60%。尽可能使你的工作服和工作台接地。

- The LCD module is coated with a film to protect the display surface. Exercise care when peeling off this protective film since static electricity may be generated.
- 液晶显示模块表面有一个保护膜。需要小心操作以减少撕保护膜时静电的产生。

7.13 Since LCM has been assembled and adjusted with a high degree of precision, avoid applying excessive shocks to the module or making any alterations or modifications to it.

由于液晶显示模块由高精度装配和调节制成，应避免对模块过大的冲击或做任何更改。

- Do not alter, modify or change the shape of the tab on the metal frame.
 - 不要改动金属架上的翼片形状。
- Do not make extra holes on the printed circuit board, modify its shape or change the positions of components to be attached.
 - 不要在印制电路板上钻额外的孔，修改形状或更改印制线路板上元件的位置。
- Do not damage or modify the pattern writing on the printed circuit board.
 - 不要更改或损坏印制线路板上的图案。
- Absolutely do not modify the zebra rubber strip (conductive rubber) or heat seal connector.
 - 绝对不要更改斑马条（导电胶条）或导电纸连接器。
- Except for soldering the interface, do not make any alterations or modifications with a soldering iron.
 - 除焊接接口外，不要用烙铁做任何更改。
- Do not drop, bend or twist the LCM.
 - 不要扔、弯和扭模块。

8.Packing and Storage Specification(Reference Only)包装存储

8.1 Packing Method 包装方法

(1)



将产品依次放入吸塑盘中。

Place the products in a blister tray one after another.

(2)

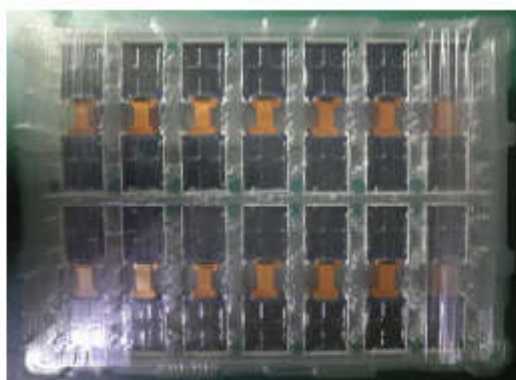

将吸塑盘相互错开叠加，共叠加 12 个吸塑盘，然后吸

塑盘两边用打包胶带缠绕，固定吸塑盘。

The blister discs are staggered and stacked with each other, a total of 12 blister discs are stacked, and then the blister discs are wrapped with packing tape on both sides to fix the blister discs.

(3)



将包装好的产品放入纸箱中，并将两包产品放入纸箱中，两包产品中间用泡棉隔开。
Put the packaged products in the carton, and put two packages of products in the carton, separated by foam between the two packages.

(4)



纸箱用胶带缠好，标签出货。

The carton is wrapped with tape and the label is shipped.

8.2 Storage Method 存储方法

1. Store in an ambient temperature of $23^{\circ}\text{C}\pm 5^{\circ}\text{C}$, and in a relative humidity of $60\%\pm 15\%$. Don't exceed 12 months and expose to sunlight or fluorescent light.

存储环境温度为 $23^{\circ}\text{C}\pm 5^{\circ}\text{C}$ ，相对湿度为 $60\%\pm 15\%$ ，存储不能超过 12 个月，不要长时间暴晒。

2. Store in a clean environment, free from dust, active gas, and solvent.

存储在一个干净的环境，不受灰尘，活性气体和溶剂污染。

3. Store in antistatic container.

存储在防静电环境。