

LED Display

Product Data Sheet

IE-1R-10802N-G

Spec No.:

Effective Date: Oct 18, 2013

FEATURES

0.8 inch (20.40mm) Digit Height
Low Power Requirement
High Brightness and High Contrast
Excellent Characters Appearance
IC Compatible , Easy Assembly
RoHS Compliant

DESCRIPTION

This is a 0.8 inch (20.40mm) digit height single digit seven segment LED display. This device utilizes red LED chips, which are made from AlGaInP, and has a gray face and white segments.

DEVICE

Red	Description
IE-1R-10802N-G	Common Anode, Right Hand Decimal
Total 8 LED Chips	

PACKAGE DIMENSIONS

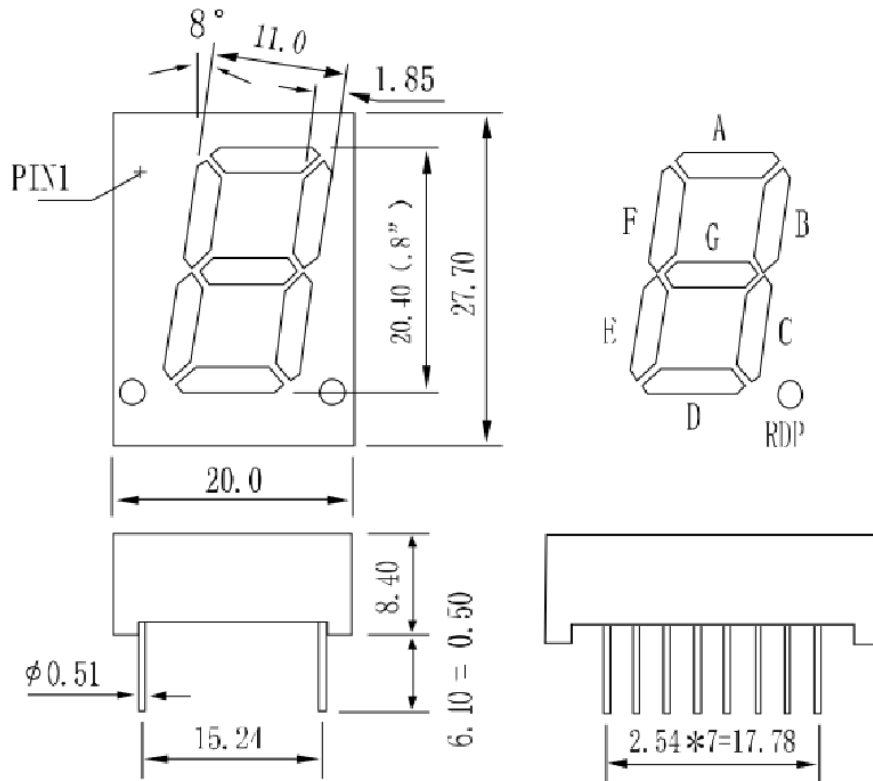

NOTES: All dimensions are in millimeters (inches). Tolerance is ± 0.25 (0.010") unless otherwise specified.

INTERNAL CIRCUIT DIAGRAM

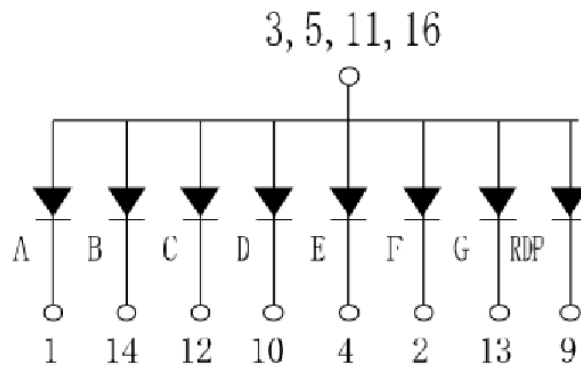

6, 7, 8, 15 NO PIN

PIN CONNECTION

PIN NO.	CONNECTION
1	CATHODE A
2	CATHODE F
3	COMMON ANODE
4	CATHODE E
5	COMMON ANODE
6	NO PIN
7	NO PIN
8	NO PIN
9	CATHODE DP
10	CATHODE D
11	COMMON ANODE
12	CATHODE C
13	CATHODE G
14	CATHODE B
15	NO PIN
16	COMMON ANODE

ABSOLUTE MAXIMUM RATINGS AT Ta=25°C

PARAMETER	SYMBOL	AlGaInP RED	UNIT
Power Dissipation Per Segment	PAD	50	mw
Reverse Voltage Per Segment	VR	5	V
Continuous Forward Current Per Segment	IAF	20	mA
Peak Forward Current Per Segment(Duty-0.1,1KHz)	IPF	60	mA
Operating Temperature Range	TOPr	-20°C to 80°C	
Storage Temperature Range	Tstg	-30°C to 85°C	
Lead Soldering Temperature 260°C at 1.6mm From Body for 3 second			

ELECTRICAL/OPTICAL CHARACTERISTICS AT Ta=25°C**AlGaInP RED**

PARAMETER	SYMBOL	TEST CONDITION	MIN	TYP	MAX	UNIT
Forward Voltage, Per Segment	VF	IF=20mA	1.9	2.0	2.5	V
Reverse Current, Per Segment	IR	VR=5V			50	μA
Peak Emission Wavelength	λp	IF=20mA	630	633	637	nm
Luminous Intensity Per Segment	IV	IF=20mA	23	25	28	mcd

TYPICAL ELECTRICAL / OPTICAL CHARACTERISTIC CURVES @ TA = 25°C

